



FLY ANTWERPEN

Schrijnwerk



KATALOG TECHNICZNY PVC



CATALOGUE TECHNIQUE PVC



PVC TECHNICAL CATALOGUE



TECHNISCHER KATALOG PVC



CATALOGO TECNICO PVC



1/2020



IDEAL 4000

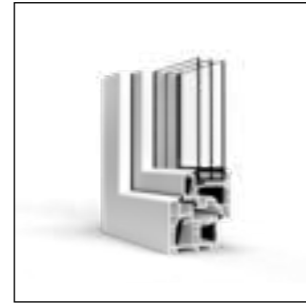

ENERGETO 8000



EASY SLIDE ST 60



STREAMLIN 76



EKOSUN 70



S 9000



IDEAL 4000 NEW



BLOCKPROFIL



MULTI SLIDE ST 80



BLUEEVOLUTION 82



EKOSUN 6



HST GEALAN



IDEAL 5000



MONOBLOCK



SMART SLIDE



BLUEEVOLUTION 92



EKOSUN 7



IDEAL 7000 NEW



NORDLINE



HST 70



EVOLUTIONDRIVE SF



HST EKOSUN



IDEAL 8000



IDEAL 70 / CASEMENET



HST 85



EVOLUTIONDRIVE 82

ALUPLAST +

SALAMANDER +

EKOSUN +

GEALAN +

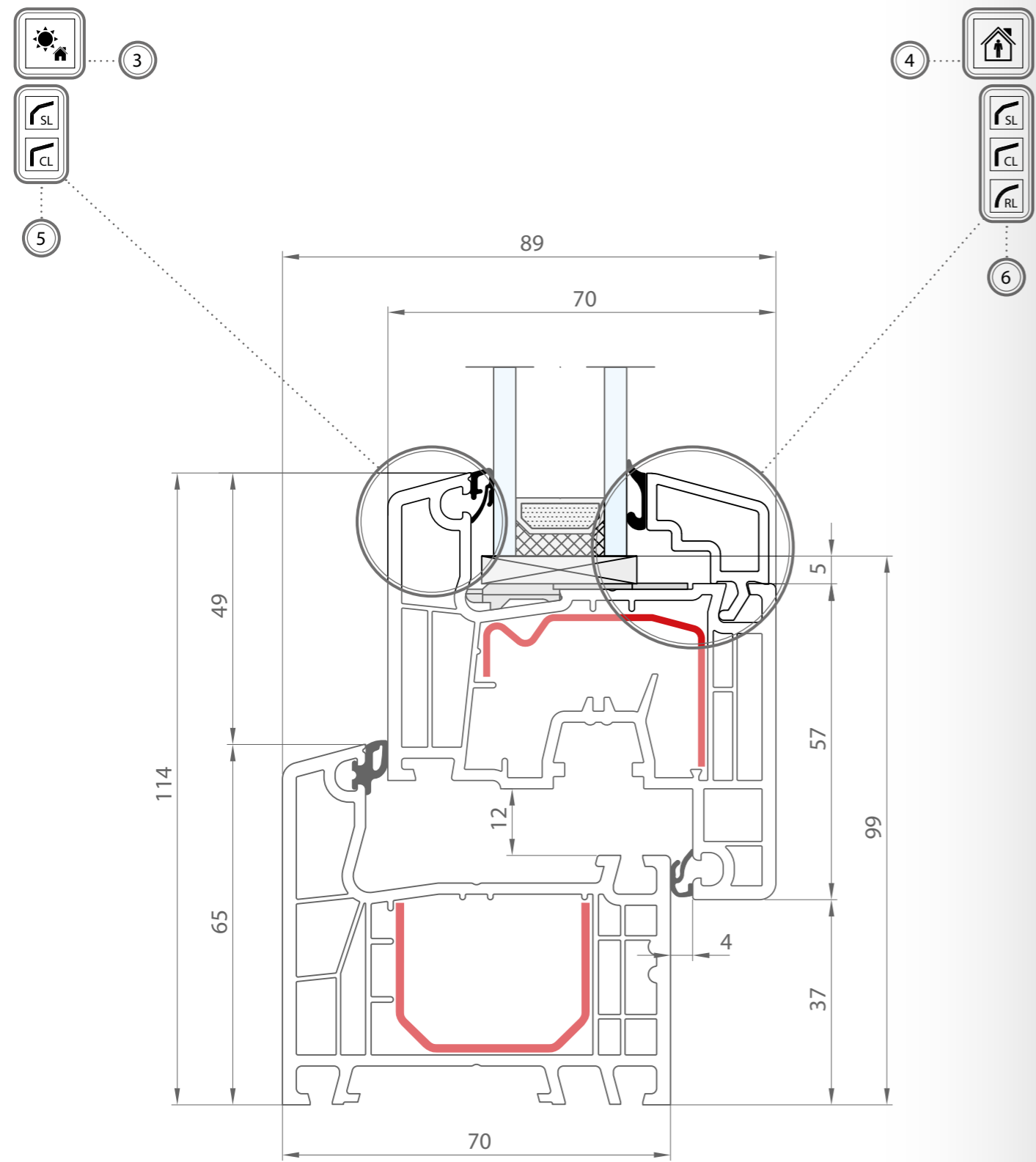

- 1 Rama: 65 mm · Skrzydło: 77 mm
- 2 Dormant: 65 mm · Vantail: 77 mm
- 3 Frame: 65 mm · Sash: 77 mm
- 4 Rahmen: 65 mm · Flügel: 77 mm
- 5 Telaio: 65 mm · Anta: 77 mm

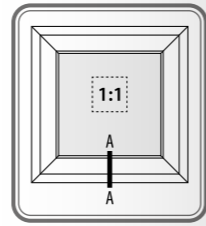

Opis oznaczeń · Description des marquages · Descriptions of markings
Beschreibung · Descrizione delle marcature

- 1 Nazwa systemu
Nom du système
Name of a system
System
Nome del sistema
- 2 Numery profili
Numéros de profil
Number of profiles
Nummern der Profile
Numeri dei profili
- 3 Strona zewnętrzna
Face extérieure
External side
Aussenseite
Parte esterna
- 4 Strona wewnętrzna
Face intérieure
Internal side
Innenseite
Parte interna
- 5 Wykończenie zewnętrzne skrzydła
Finition extérieure des l'ouvrant
Finished of an external sash
Ausführung der Innenseite es Flügels
Finitura esterna dell'anta
- 6 Wykończenie listwy przyszybowej
Finition de la parclose
Finished of a glazing bead
Ausführung der Glasleiste
Finitura del fermavetro
- 7 Opis rysunku - szerokość profili
Description du dessin
Description of a drawing
Beschreibung der Zeichnung
Descrizione del disegno
- 8 Miejsce i skala przekroju
Endroit et échelle de la coupe
Place and scale of the cross-section
Stelle und Skala des Querschnitts
Luogo e scala della sezione

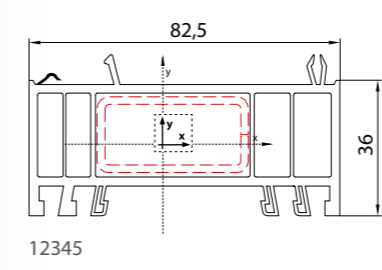

	0,0	-	lx 0,0	ly 0,0
	2,0	12345	lx 1,4	ly 4,1
Wzmocnienie	Grubość	Kod	Moment bezwładności [cm ⁴]	
Renforcement	Épaisseur	Code	Moment d'inertie [cm ⁴]	
Reinforcement	Thickness	Code	Moment of inertia [cm ⁴]	
Verstärkung	Stärke	Code	Flächenträgheitsmoment [cm ⁴]	
Rinforzo	Spessore	Codice	Momento di inerzia [cm ⁴]	

Przedstawiono wzmocnienia standardowe dla konstrukcji w kolorze białym o wymiarach referencyjnych.

Les renforts standard pour une structure de couleur blanche de dimension de référence ont été présentés.

Standard reinforcements for white constructions with reference dimensions are presented

Es wurden standard Verstärkungen bei weißen Elementen mit Referenzmassen dargestellt

Sono stati presentati i rinforzi standard delle costruzioni di colore bianco con dimensioni di riferimento.

Opis oznaczeń · Description des marquages · Descriptions of markings
Beschreibung · Descrizione delle marcature



- Ilość komór
- Nombre de chambres
- Number of chambers
- Anzahl Kammern
- Quantita' di camere



- Ilość uszczelek
- Nombre de jointns
- Number of gaskets
- Anzahl Dichtungen
- Quantita' delle guarnizioni



- Głębokość zabudowy
- Profondeur de construction
- Installation depth
- Bautiefe
- Profondita' di montaggio



- Max grubość wypełnienia
- Épaisseur max du vitrage
- Max filing thickness
- Maximale Stärke der Verglasung
- Massimo spessore del riempimento



- Strona zewnętrzna
- Face extérieure
- External side
- Aussenseite
- Parte esterna



- Strona wewnętrzna
- Face intérieure
- Internal side
- Innenseite
- Parte interna



- Rodzaj zgrzewu
- Type de soudure
- Welding type
- Art der Schweißnaht
- Tipo di saldatura



- Możliwość zamówienia profilu w klasie A
- Possibilité de commander le profilé de classe A
- It is possible to order a profile in A class
- Auch als A-Klasse-Profil erhältlich
- Possibilita' di ordinare il profilo di classe A



- Okucie okienne
- Ferrage de fenêtre
- Window fitting
- Fenster-Beschlag
- Ferramenta di finestre



- Okucie drzwiowe
- Ferrage de porte
- Door fitting
- Tür-Beschlag
- Ferramenta di porte



- Technologia szyby wklejanej
- Technologie de vitrage collé
- Bonded glass technology
- Glas verklebt
- Tecnologia del vetro incollato



- Nakładki aluminiowe
- Capotage aluminium
- Aluminium covers
- Aluschale
- Coperture in alluminio



Soft-line



Round-line



Classic-line



History-line

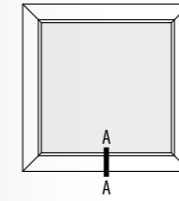

- Okno ze stałym szkleniem
- Fenêtre fixe
- Window with a fixed glazing
- Festverglasung
- Finestre fisse

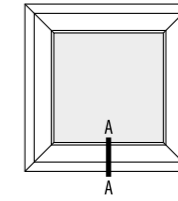

- Rama - skrzydło
- Dormant - Ouvrant
- Frame - Sash
- Rahmen - Flügel
- Telaio - Anta

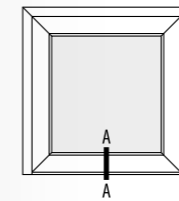

- Próg - skrzydło
- Seuil - Ouvrant
- Threshold - Sash
- Schwelle - Flügel
- Soglia - Anta

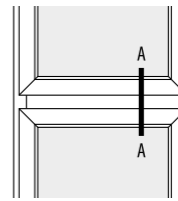

- Poprzeczka
- Traverse
- Muntin bar
- Kämpfer
- Traverso

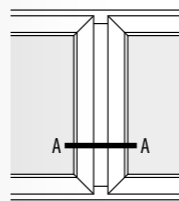

- Słupek stały
- Meneau fixe
- Fixed post
- Fester Pfosten
- Montante fisso

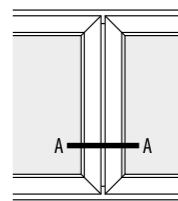

- Słupek ruchomy
- Meneau mobile
- Moveable post
- Stulp
- Montante mobile

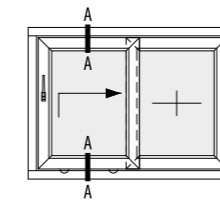
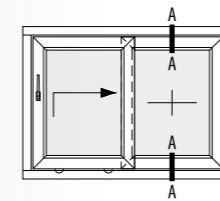

- Schemat A - przekrój pionowy
- Schéma A - coupe verticale
- Scheme A - vertical intersection
- Schema A - Senkrechter Querschnitt
- Schema A - intersezione verticale

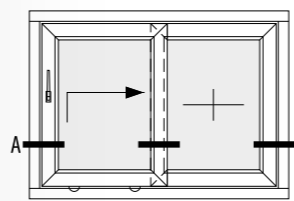

- Schemat A - przekrój poziomy
- Schéma A - coupe horizontale
- Scheme A - horizontal intersection
- Schema A - Waagerechter Querschnitt
- Schema A - intersezione orizzontale



aluplast®

Kunststoff-Fenstersysteme

IDEAL 4000

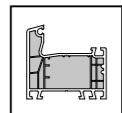
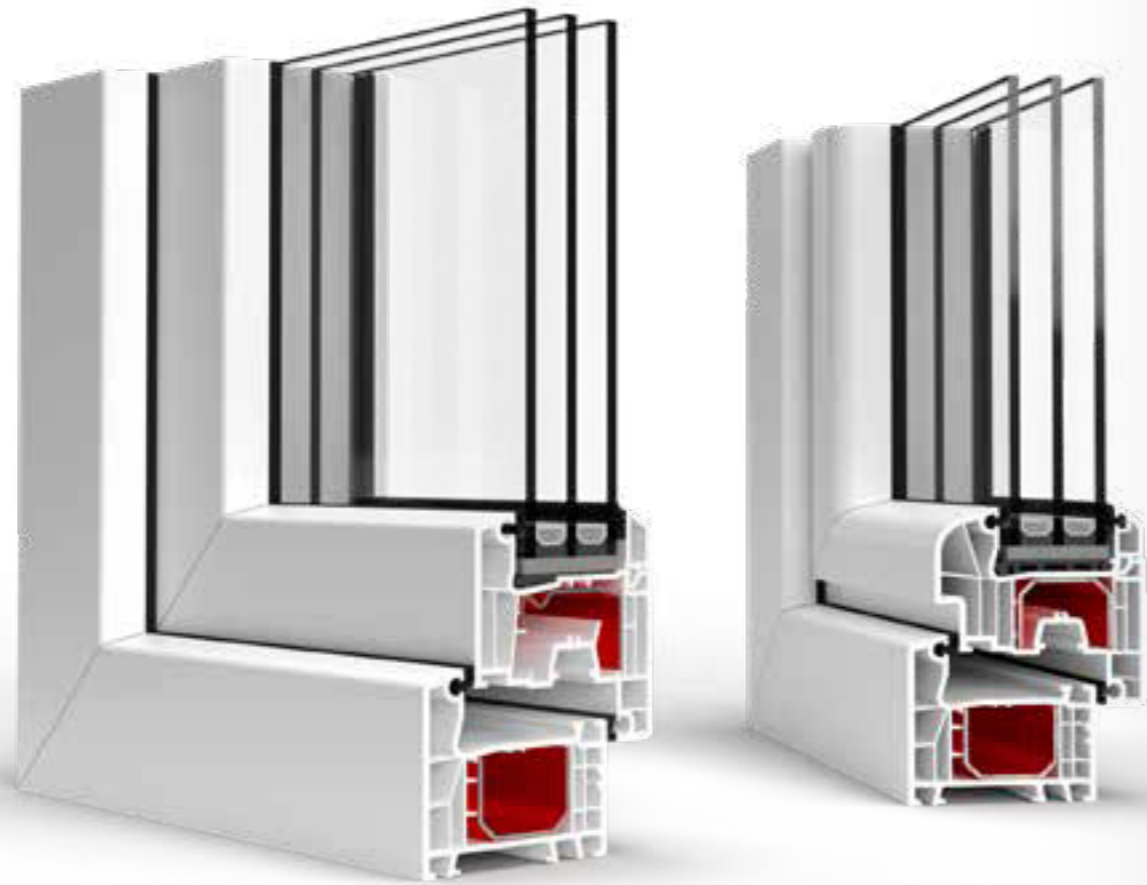

5



2

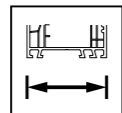

70

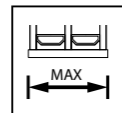

42

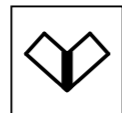

V-SUPER SOLUTION

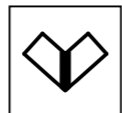

V-PERFECT TECHNOLOGY



ALU



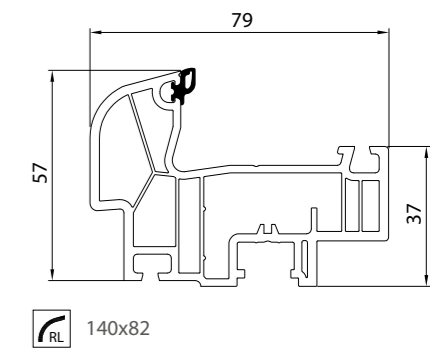
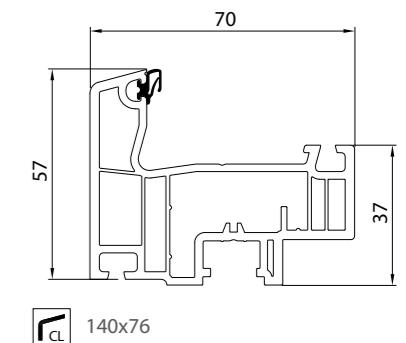
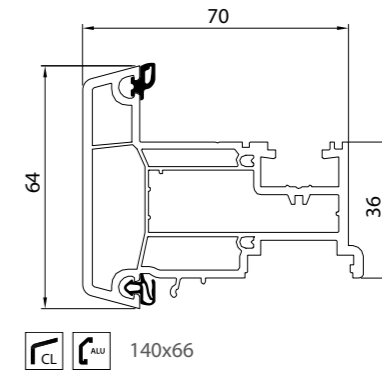
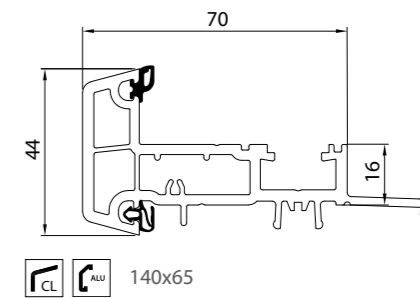
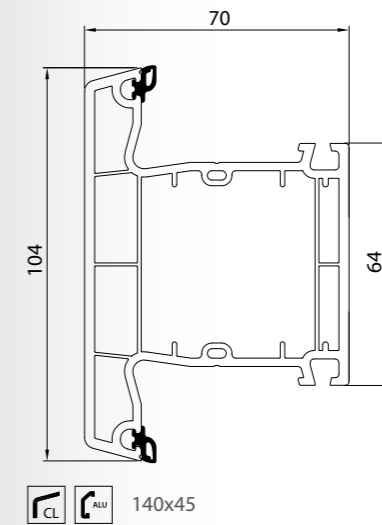
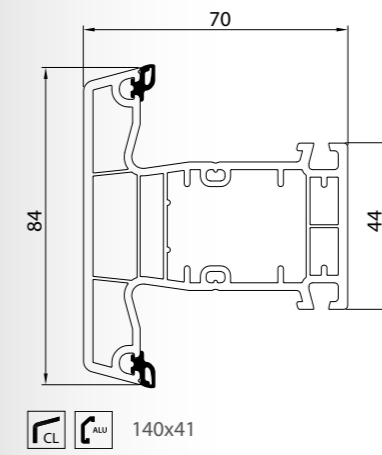
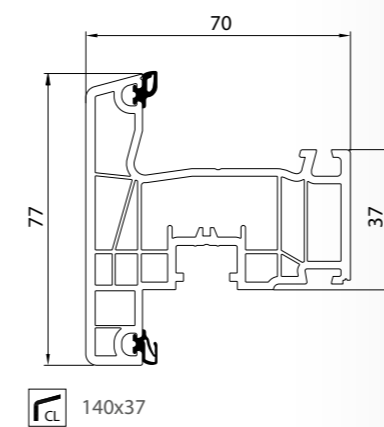
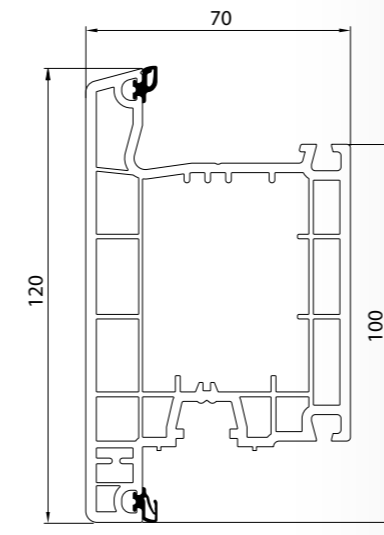
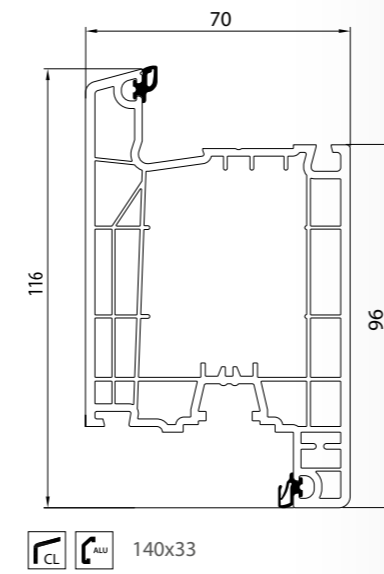
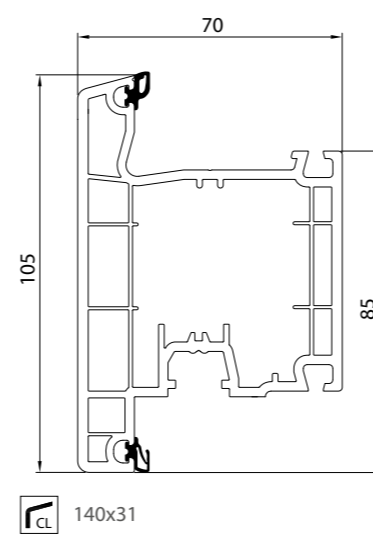
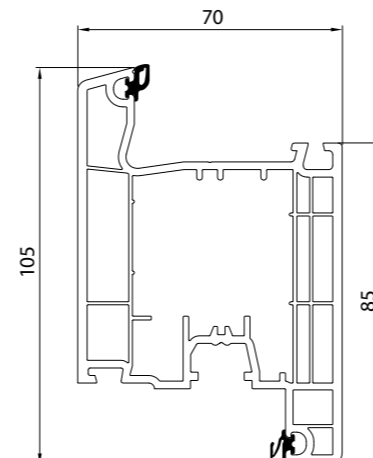
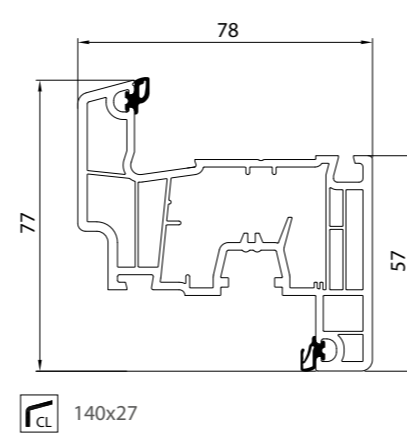
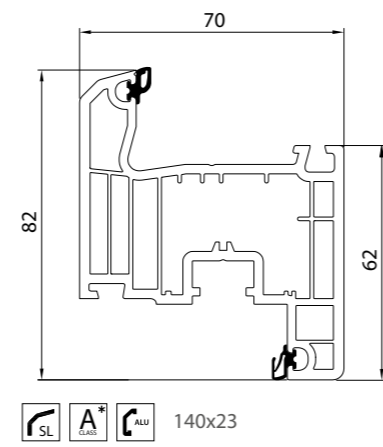
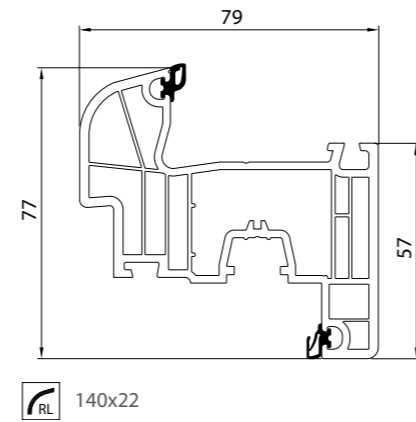
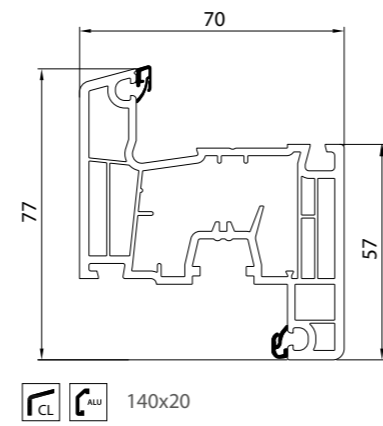
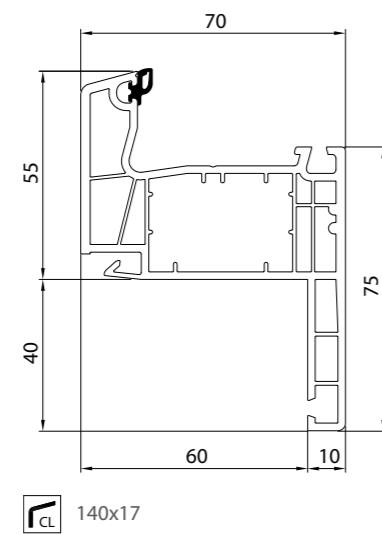
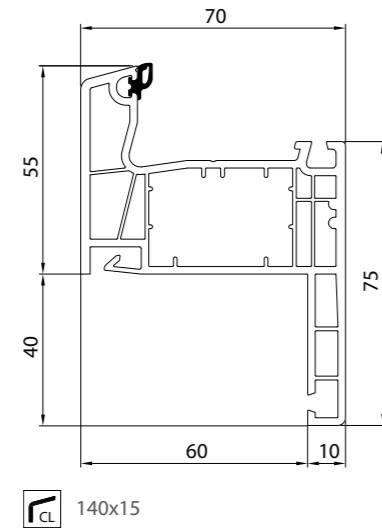
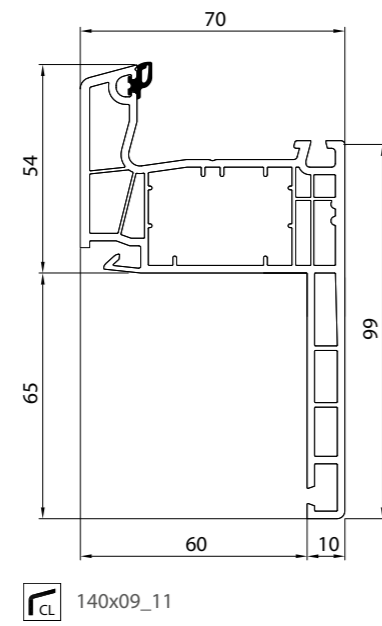
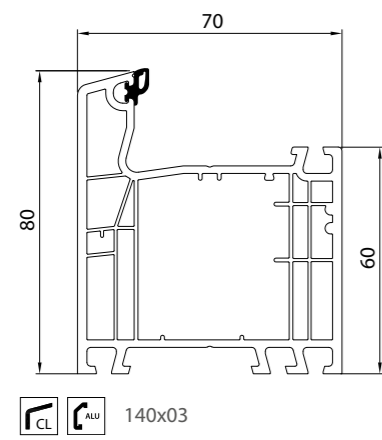
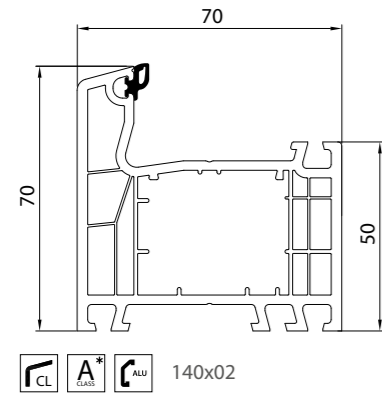
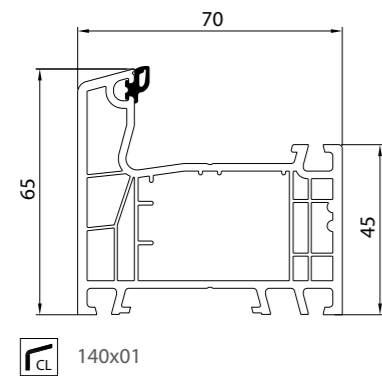

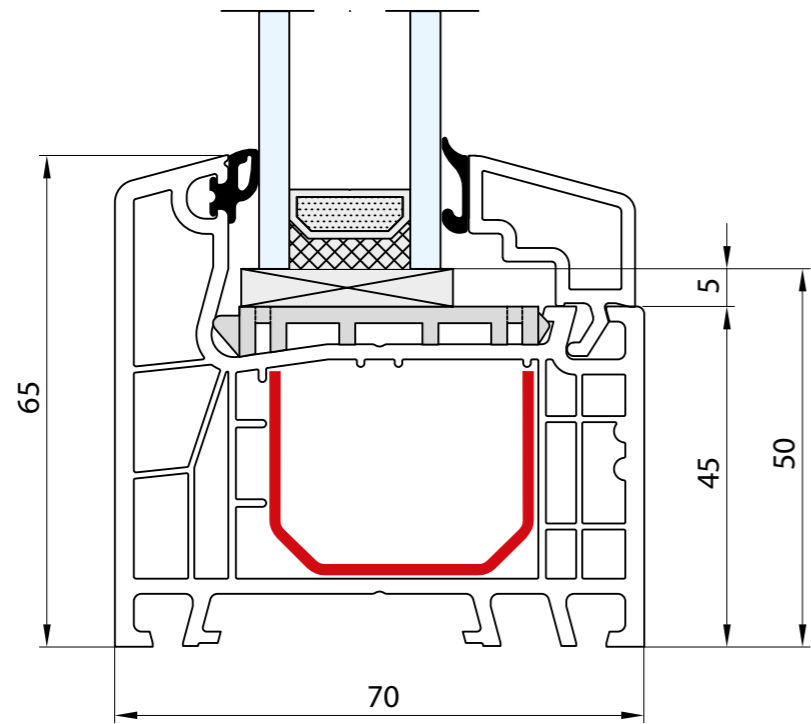

- Rama: 65 mm
- Dormant: 65 mm
- Frame: 65 mm
- Rahmen: 65 mm
- Telaio: 65 mm

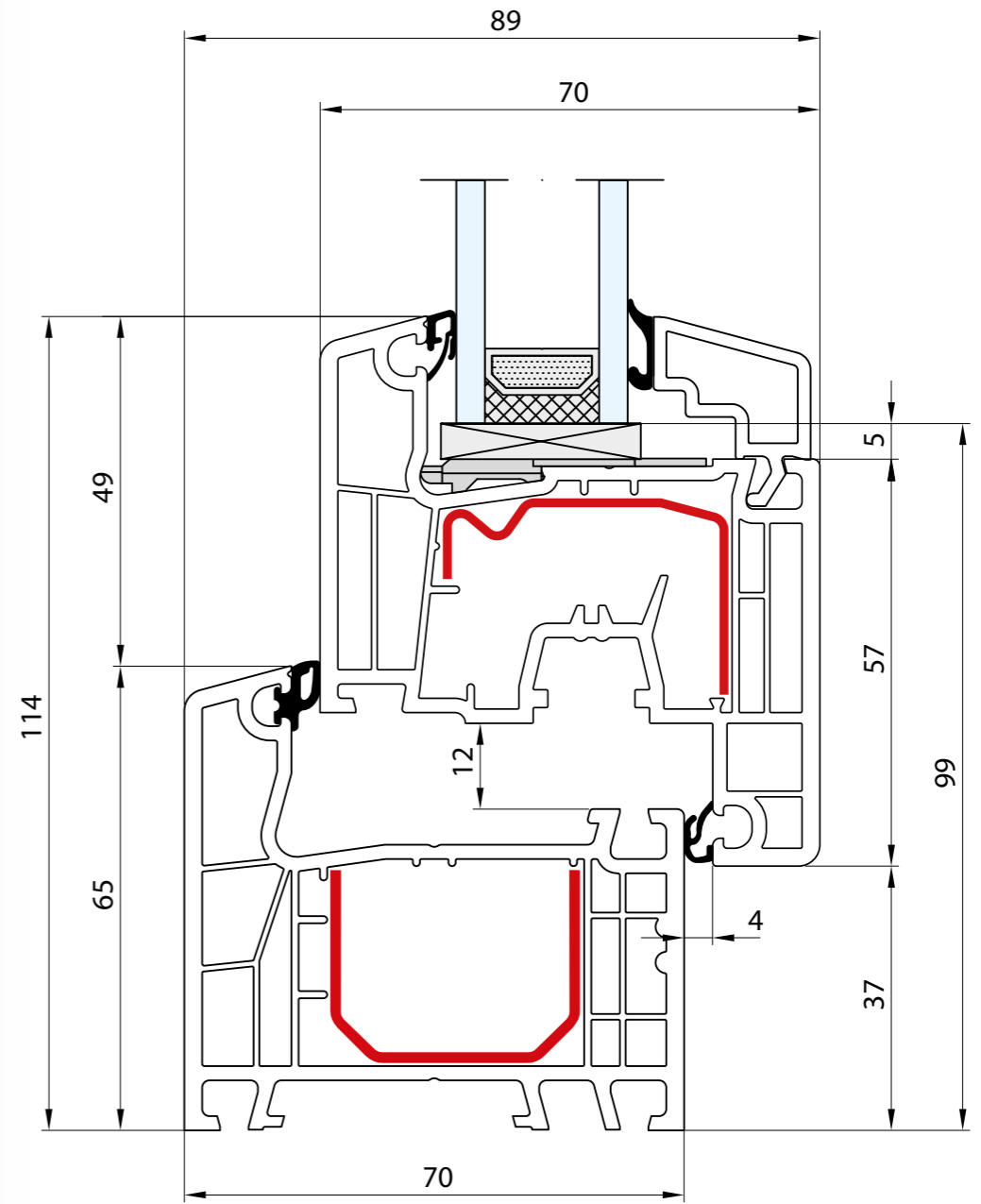
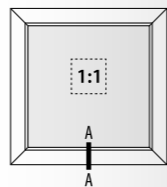

- Rama: 65 mm · Skrzydło: 77 mm
- Dormant: 65 mm · Vantail: 77 mm
- Frame: 65 mm · Sash: 77 mm
- Rahmen: 65 mm · Flügel: 77 mm
- Telaio: 65 mm · Anta: 77 mm

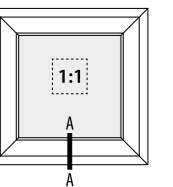

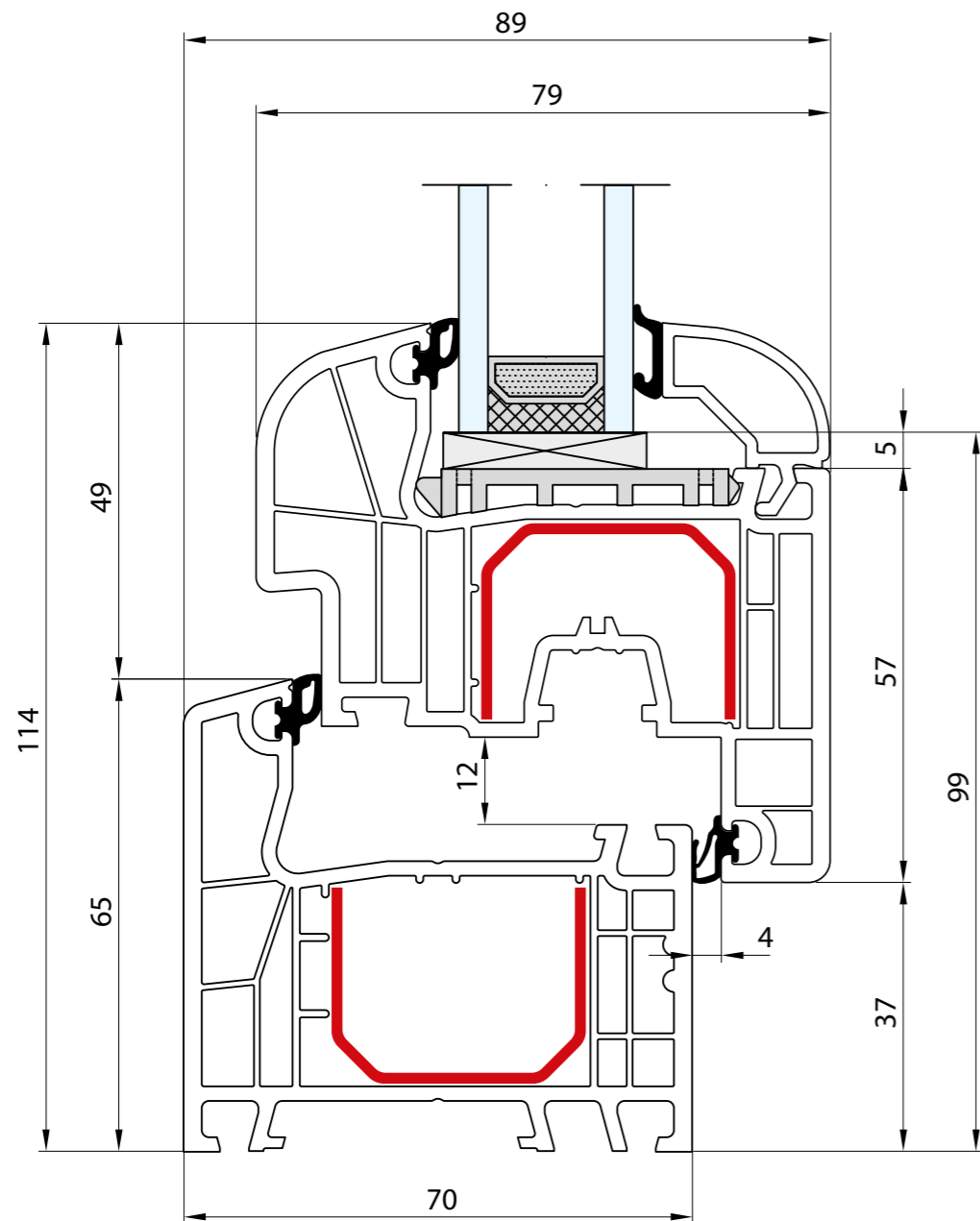

- Rama: 65 mm · Skrzydło: 77 mm
- Dormant: 65 mm · Vantail: 77 mm
- Frame: 65 mm · Sash: 77 mm
- Rahmen: 65 mm · Flügel: 77 mm
- Telaio: 65 mm · Anta: 77 mm

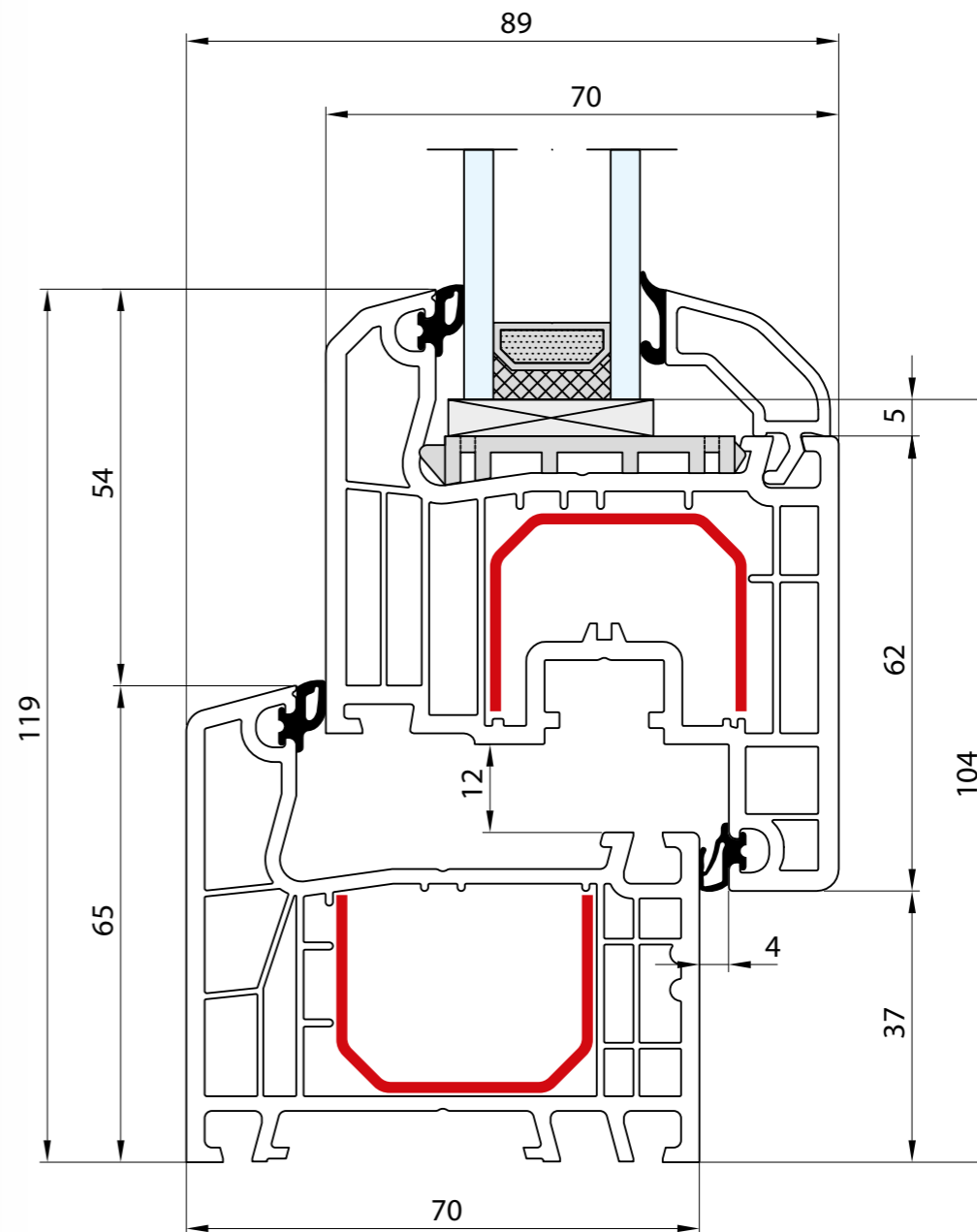
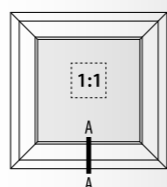

- Rama: 65 mm · Skrzydło: 82 mm
- Dormant: 65 mm · Vantail: 82 mm
- Frame: 65 mm · Sash: 82 mm
- Rahmen: 65 mm · Flügel: 82 mm
- Telaio: 65 mm · Anta: 82 mm

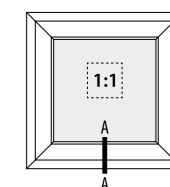

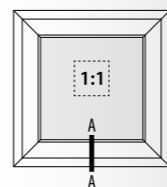
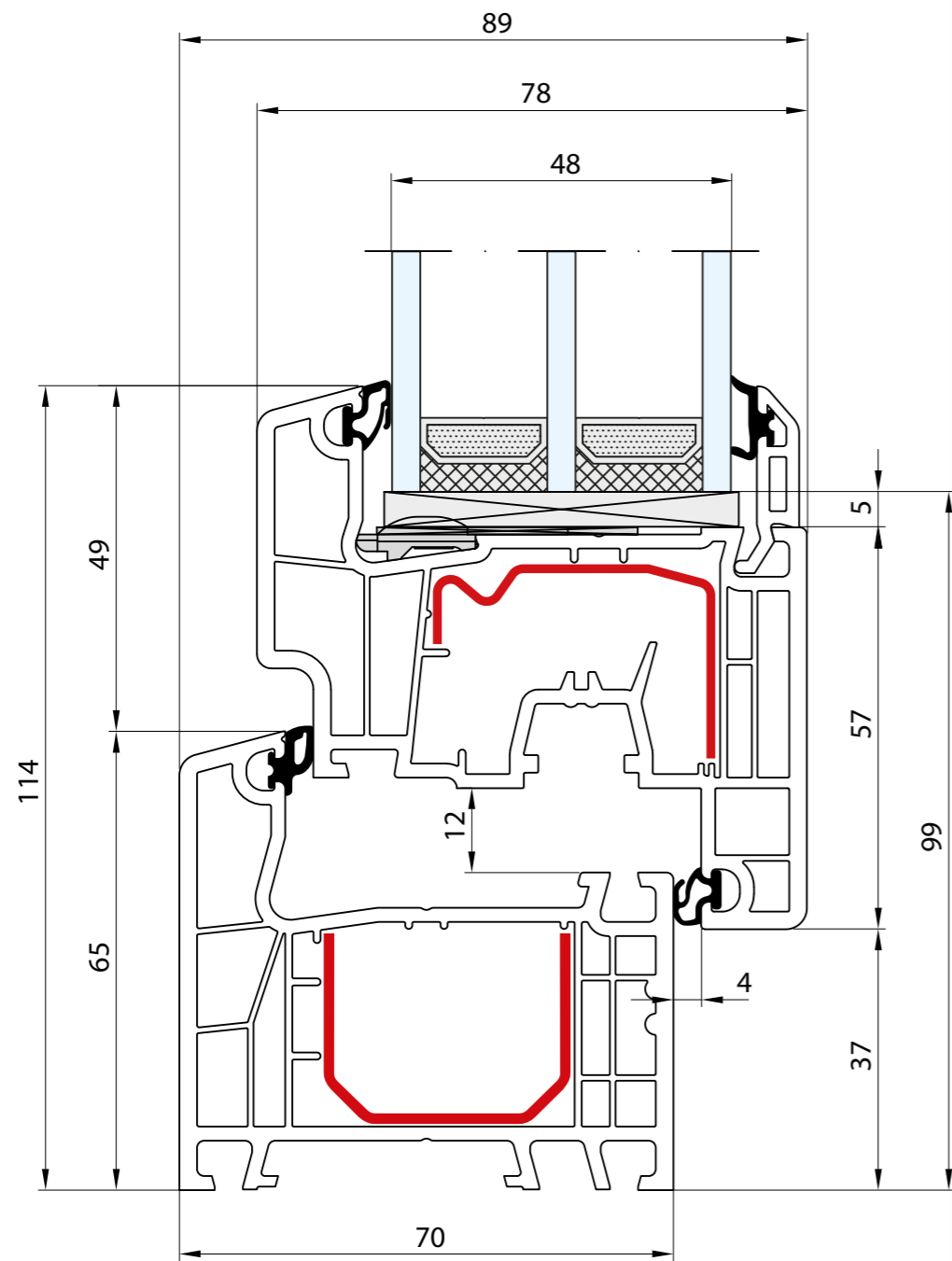

- Rama: 65 mm · Skrzydło: 77 mm
- Dormant: 65 mm · Vantail: 77 mm
- Frame: 65 mm · Sash: 77 mm
- Rahmen: 65 mm · Flügel: 77 mm
- Telaio: 65 mm · Anta: 77 mm

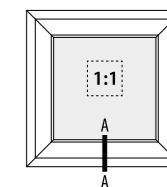
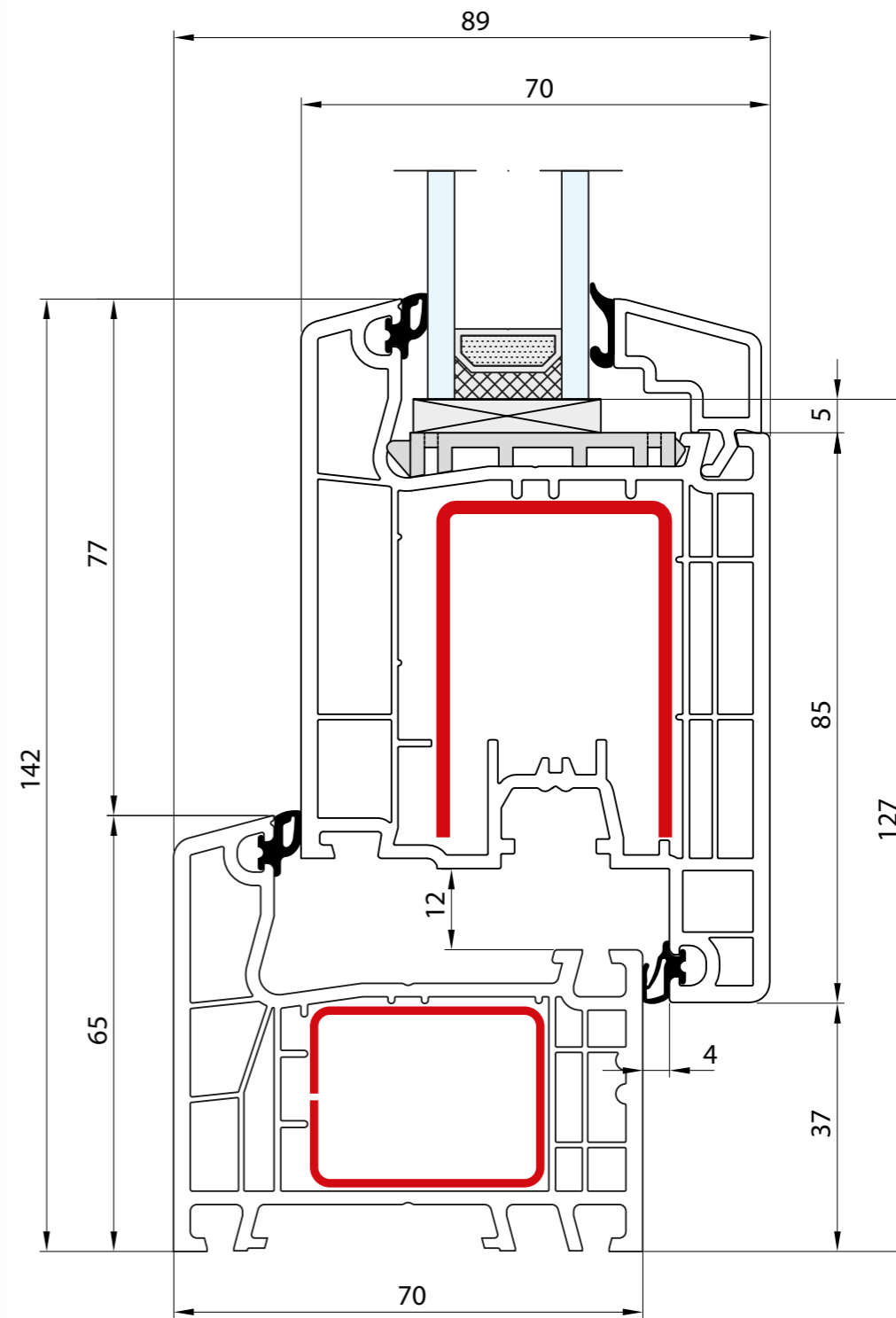

- Rama: 65 mm · Skrzydło: 105 mm
- Dormant: 65 mm · Vantail: 105 mm
- Frame: 65 mm · Sash: 105 mm
- Rahmen: 65 mm · Flügel: 105 mm
- Telaio: 65 mm · Anta: 105 mm

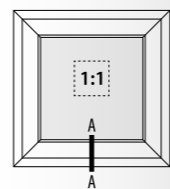
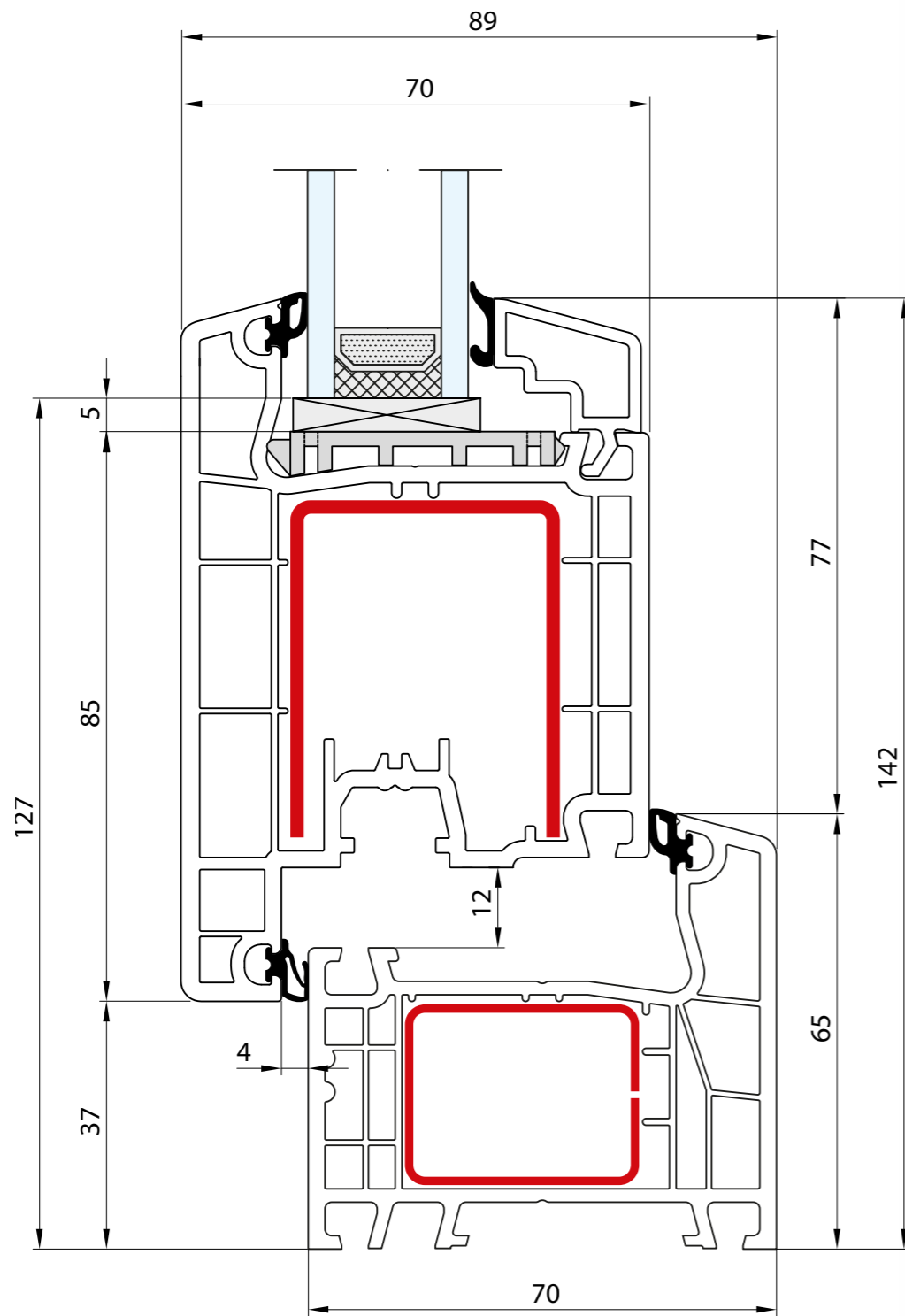

- Rama: 65 mm · Skrzydło: 105 mm
- Dormant: 65 mm · Vantail: 105 mm
- Frame: 65 mm · Sash: 105 mm
- Rahmen: 65 mm · Flügel: 105 mm
- Telaio: 65 mm · Anta: 105 mm

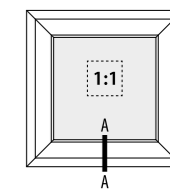
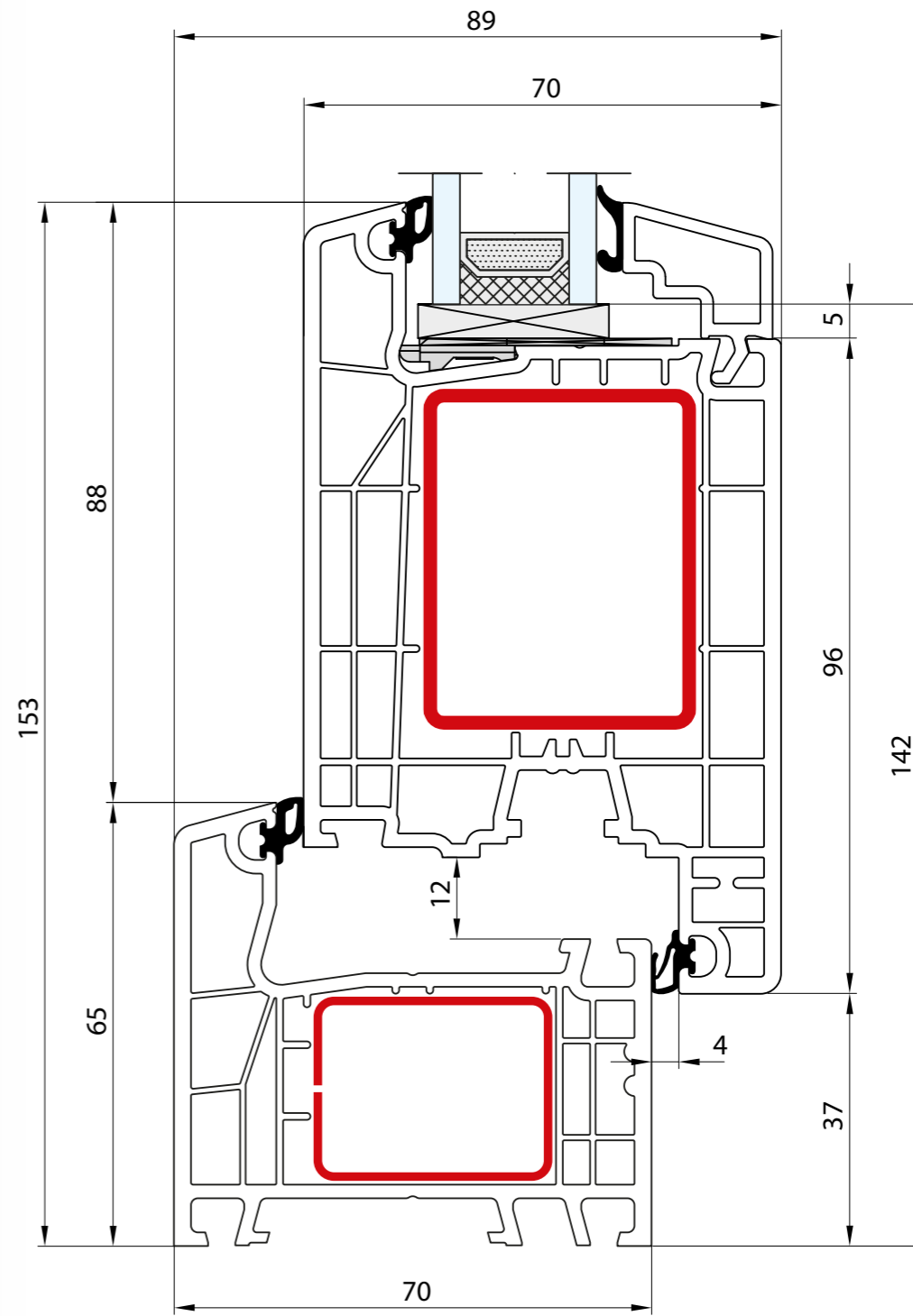

- Rama: 65 mm · Skrzydło: 116 mm
- Dormant: 65 mm · Vantail: 116 mm
- Frame: 65 mm · Sash: 116 mm
- Rahmen: 65 mm · Flügel: 116 mm
- Telaio: 65 mm · Anta: 116 mm

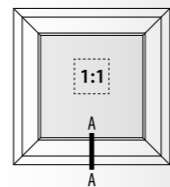
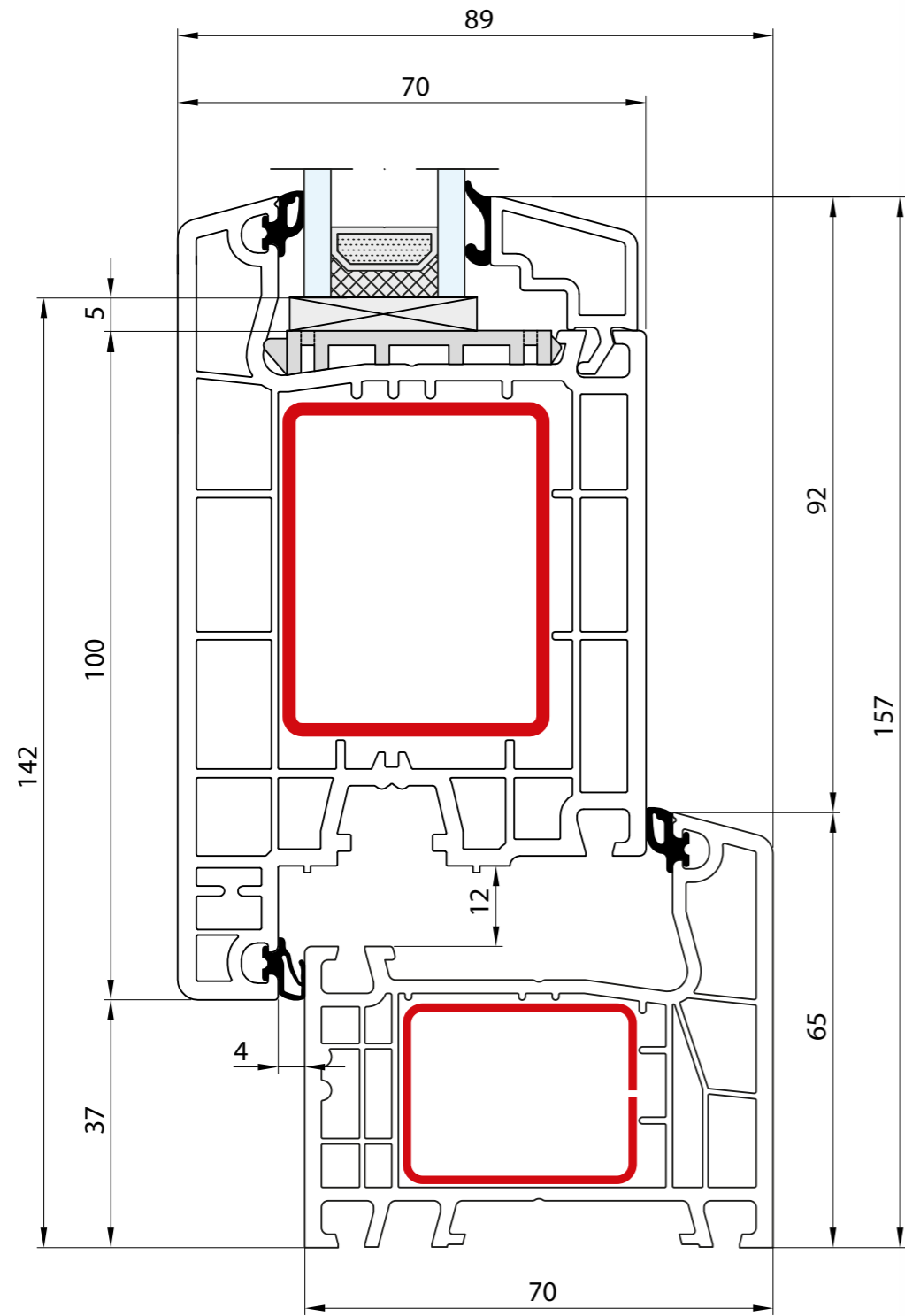

- Rama: 65 mm · Skrzydło: 120 mm
- Dormant: 65 mm · Vantail: 120 mm
- Frame: 65 mm · Sash: 120 mm
- Rahmen: 65 mm · Flügel: 120 mm
- Telaio: 65 mm · Anta: 120 mm

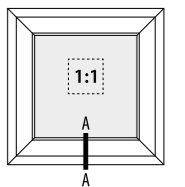
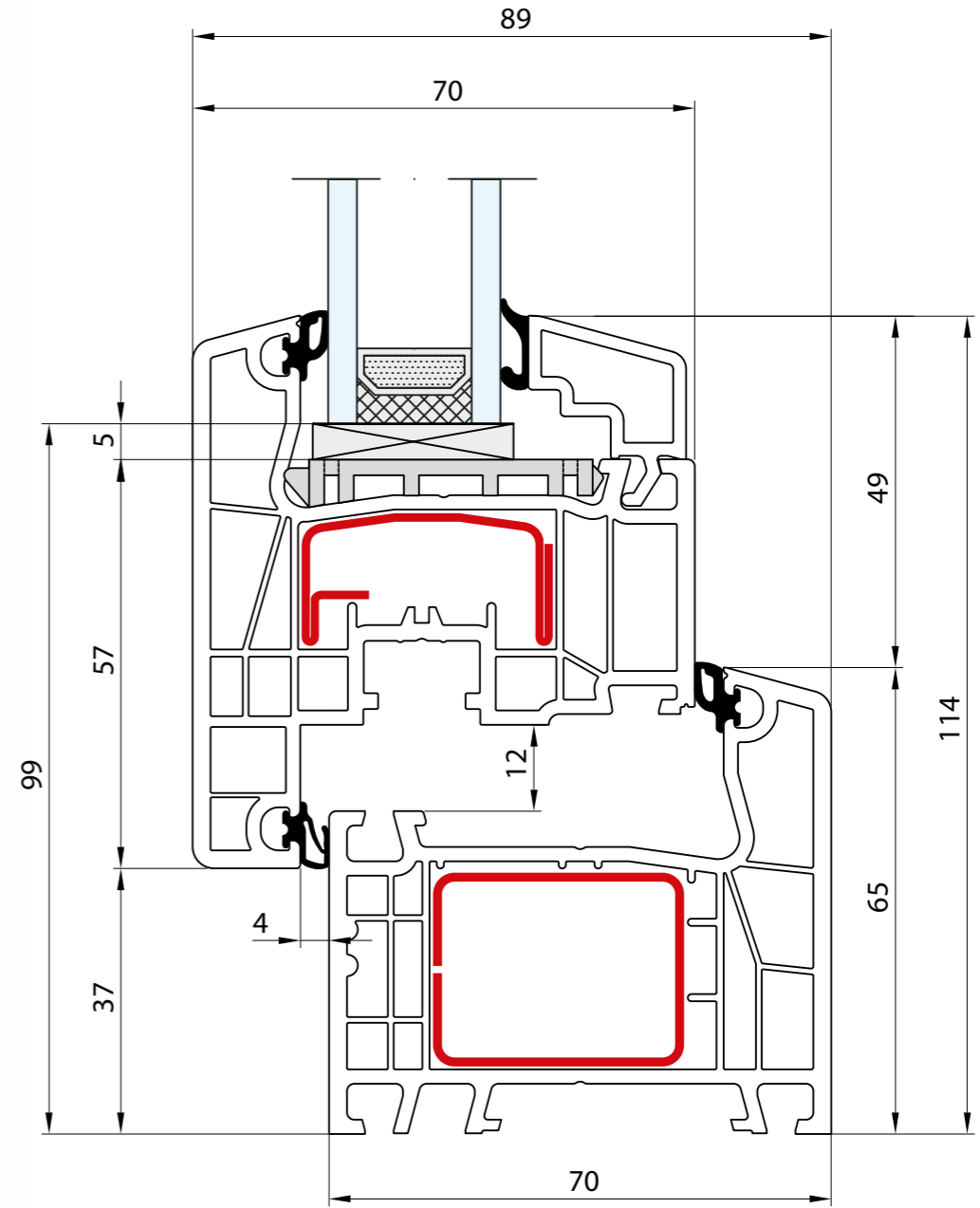

- Rama: 65 mm · Skrzydło: 77 mm
- Dormant: 65 mm · Vantail: 77 mm
- Frame: 65 mm · Sash: 77 mm
- Rahmen: 65 mm · Flügel: 77 mm
- Telaio: 65 mm · Anta: 77 mm

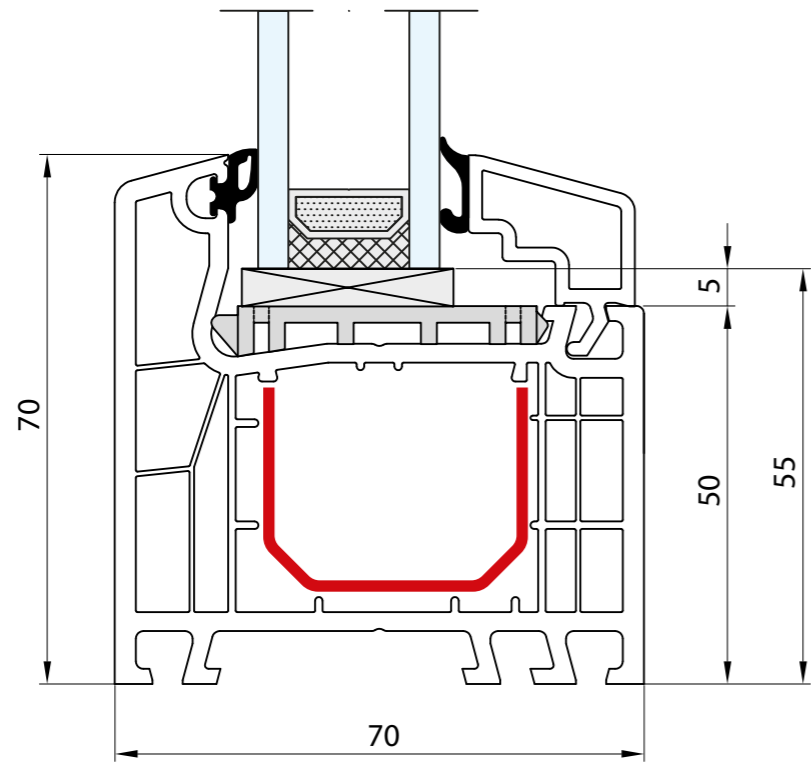

- Rama: 70 mm
- Dormant: 70 mm
- Frame: 70 mm
- Rahmen: 70 mm
- Telaio: 70 mm

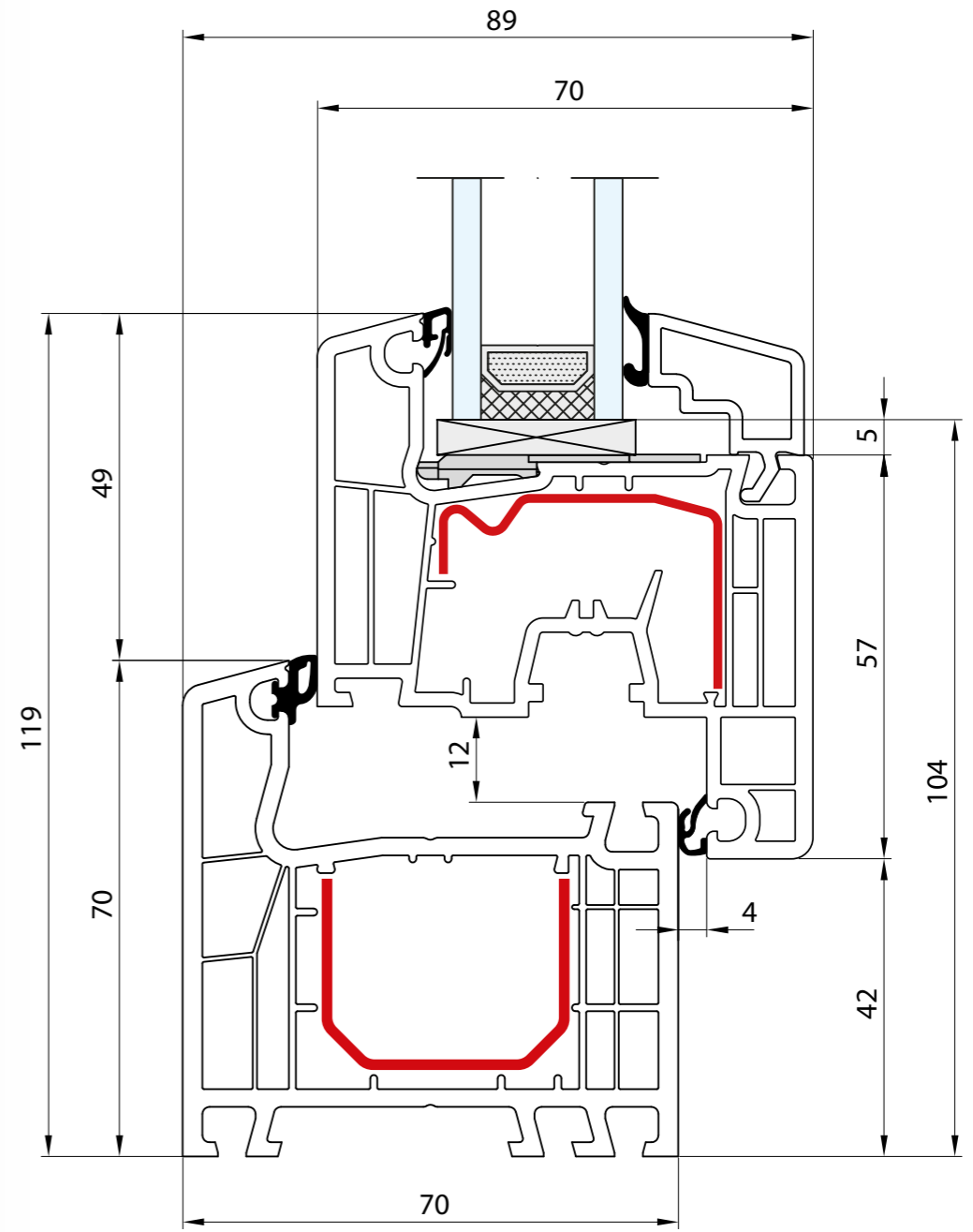
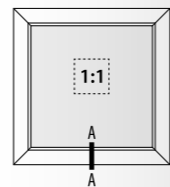

- Rama: 70 mm · Skrzydło: 77 mm
- Dormant: 70 mm · Vantail: 77 mm
- Frame: 70 mm · Sash: 77 mm
- Rahmen: 70 mm · Flügel: 77 mm
- Telaio: 70 mm · Anta: 77 mm

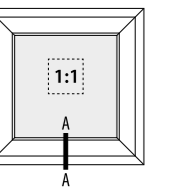

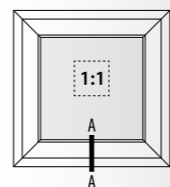
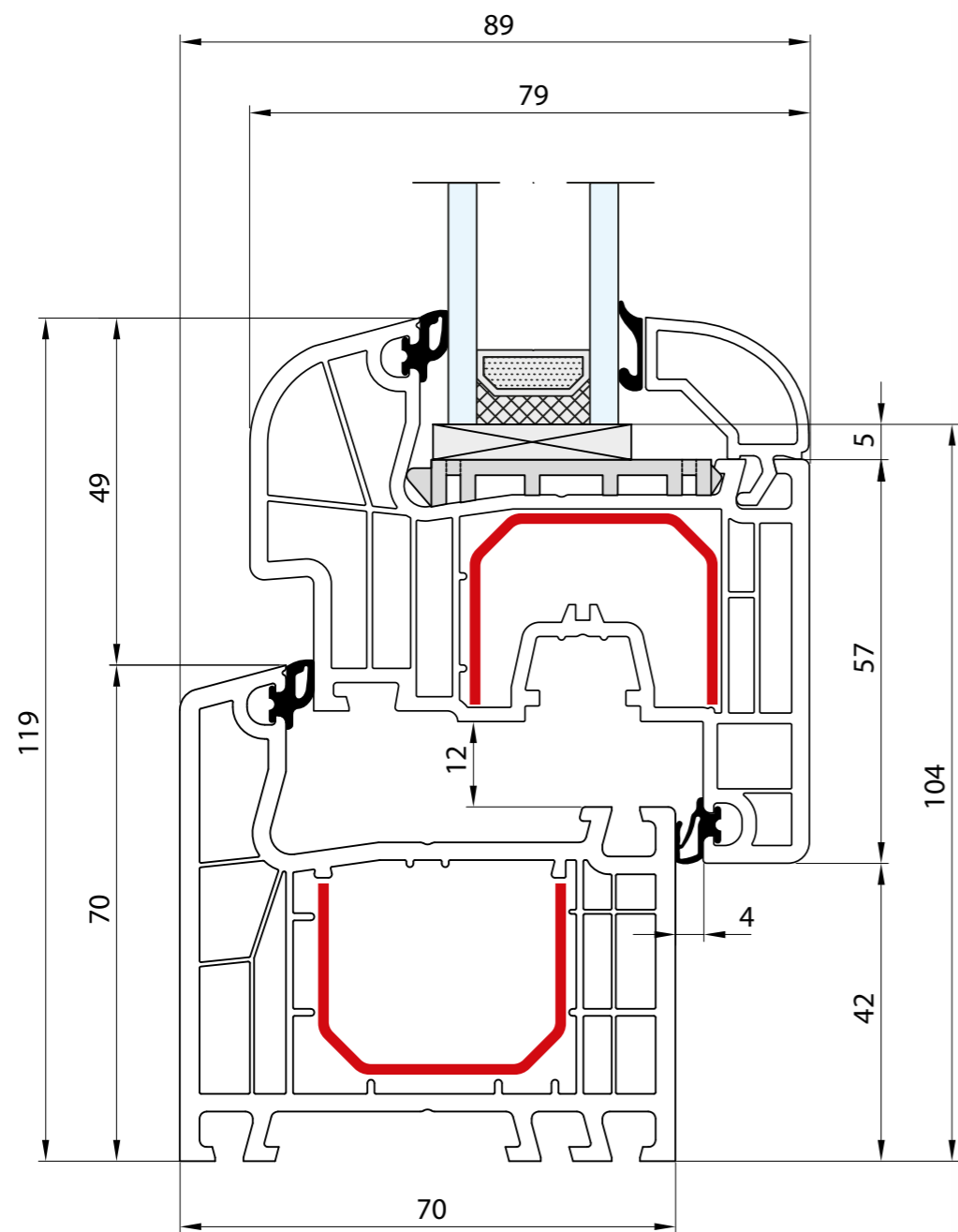

- Rama: 70 mm · Skrzydło: 77 mm
- Dormant: 70 mm · Vantail: 77 mm
- Frame: 70 mm · Sash: 77 mm
- Rahmen: 70 mm · Flügel: 77 mm
- Telaio: 70 mm · Anta: 77 mm

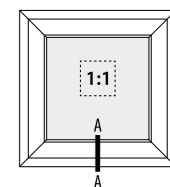
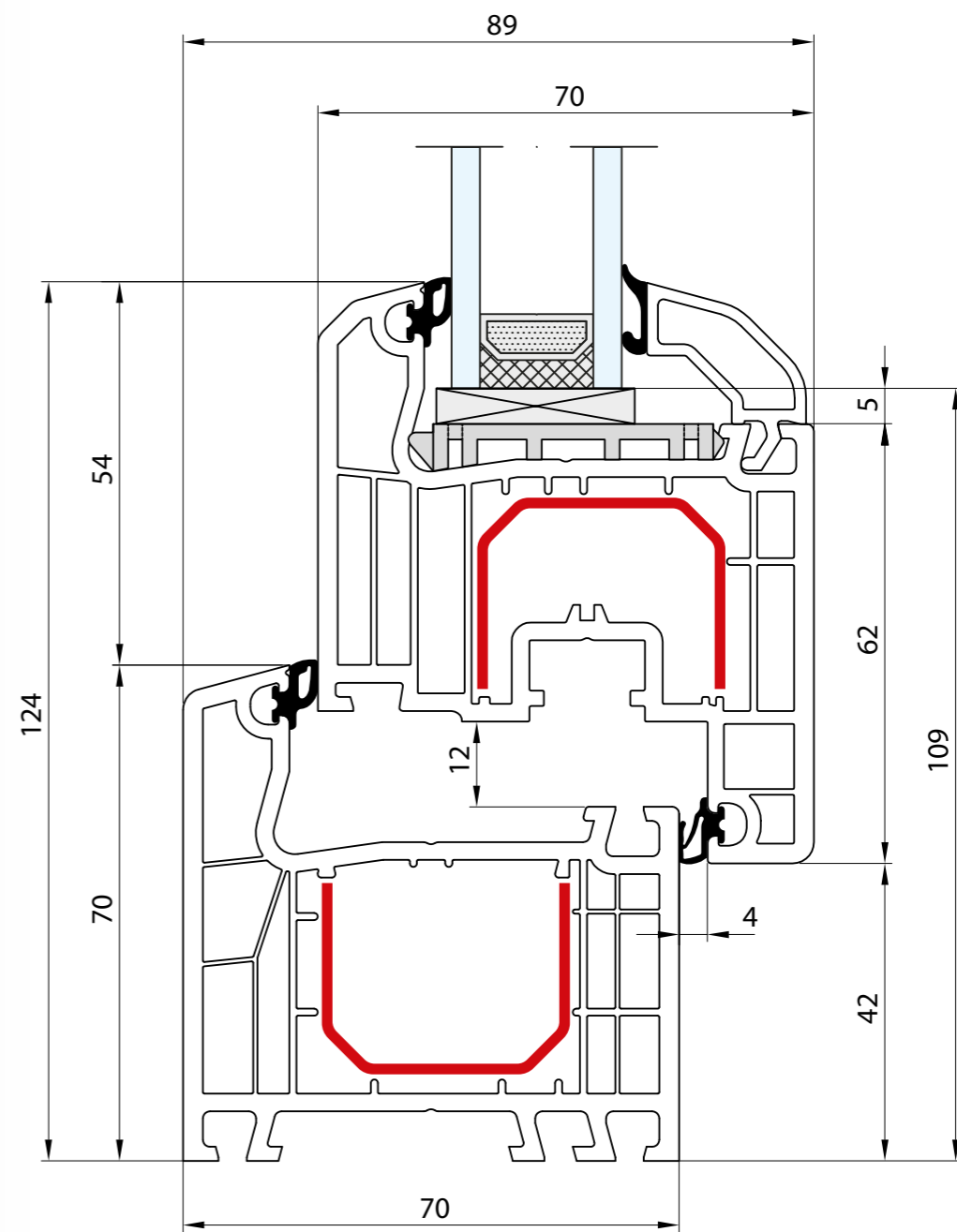

- Rama: 70 mm · Skrzydło: 82 mm
- Dormant: 70 mm · Vantail: 82 mm
- Frame: 70 mm · Sash: 82 mm
- Rahmen: 70 mm · Flügel: 82 mm
- Telaio: 70 mm · Anta: 82 mm

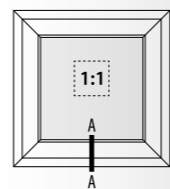
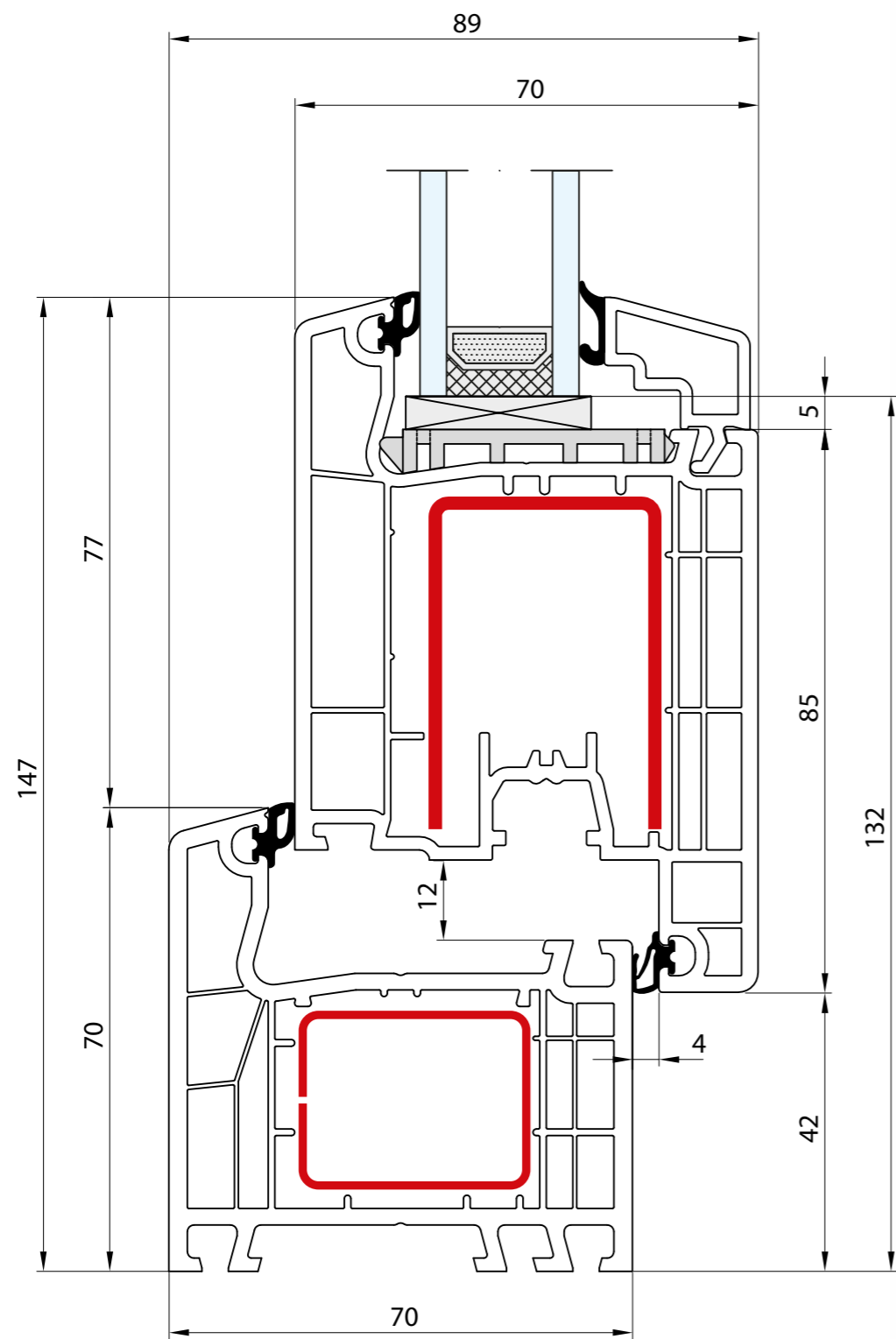

- Rama: 70 mm · Skrzydło: 105 mm
- Dormant: 70 mm · Vantail: 105 mm
- Frame: 70 mm · Sash: 105 mm
- Rahmen: 70 mm · Flügel: 105 mm
- Telaio: 70 mm · Anta: 105 mm

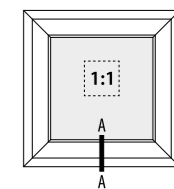
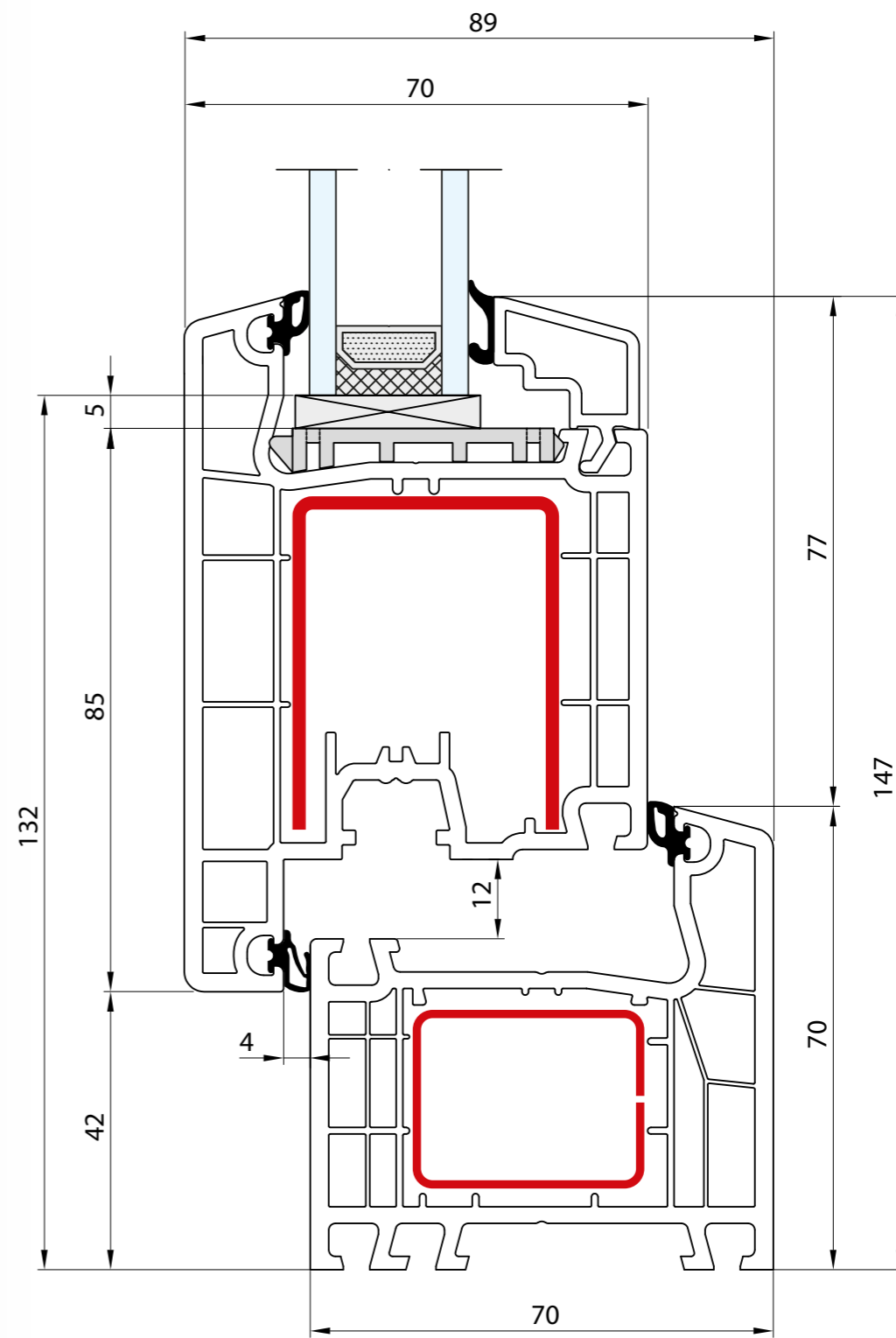

- Rama: 70 mm · Skrzydło: 105 mm
- Dormant: 70 mm · Vantail: 105 mm
- Frame: 70 mm · Sash: 105 mm
- Rahmen: 70 mm · Flügel: 105 mm
- Telaio: 70 mm · Anta: 105 mm

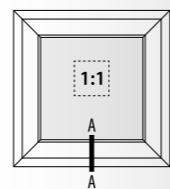
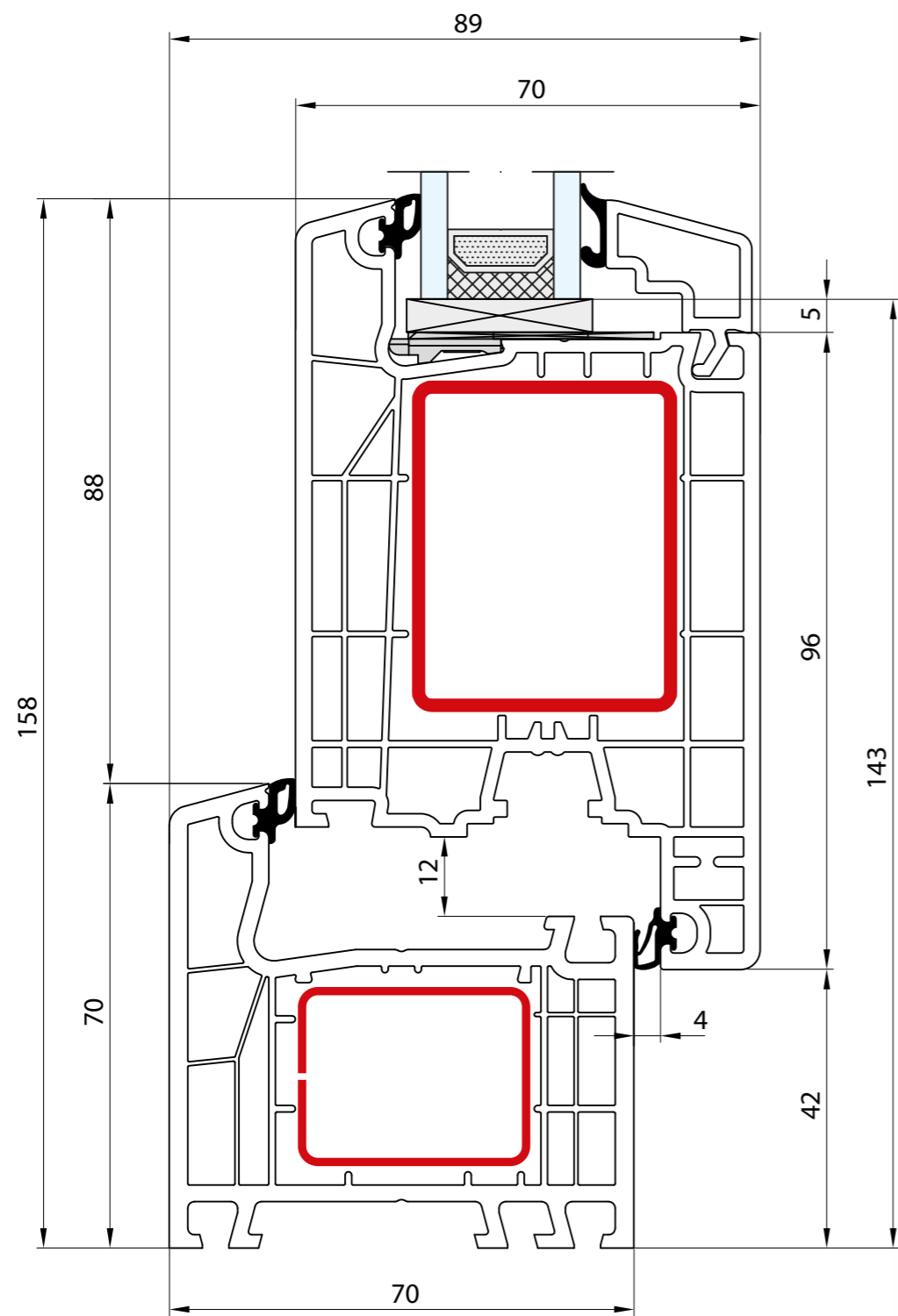

- Rama: 70 mm · Skrzydło: 116 mm
- Dormant: 70 mm · Vantail: 116 mm
- Frame: 70 mm · Sash: 116 mm
- Rahmen: 70 mm · Flügel: 116 mm
- Telaio: 70 mm · Anta: 116 mm

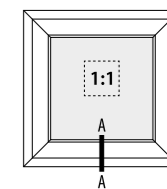
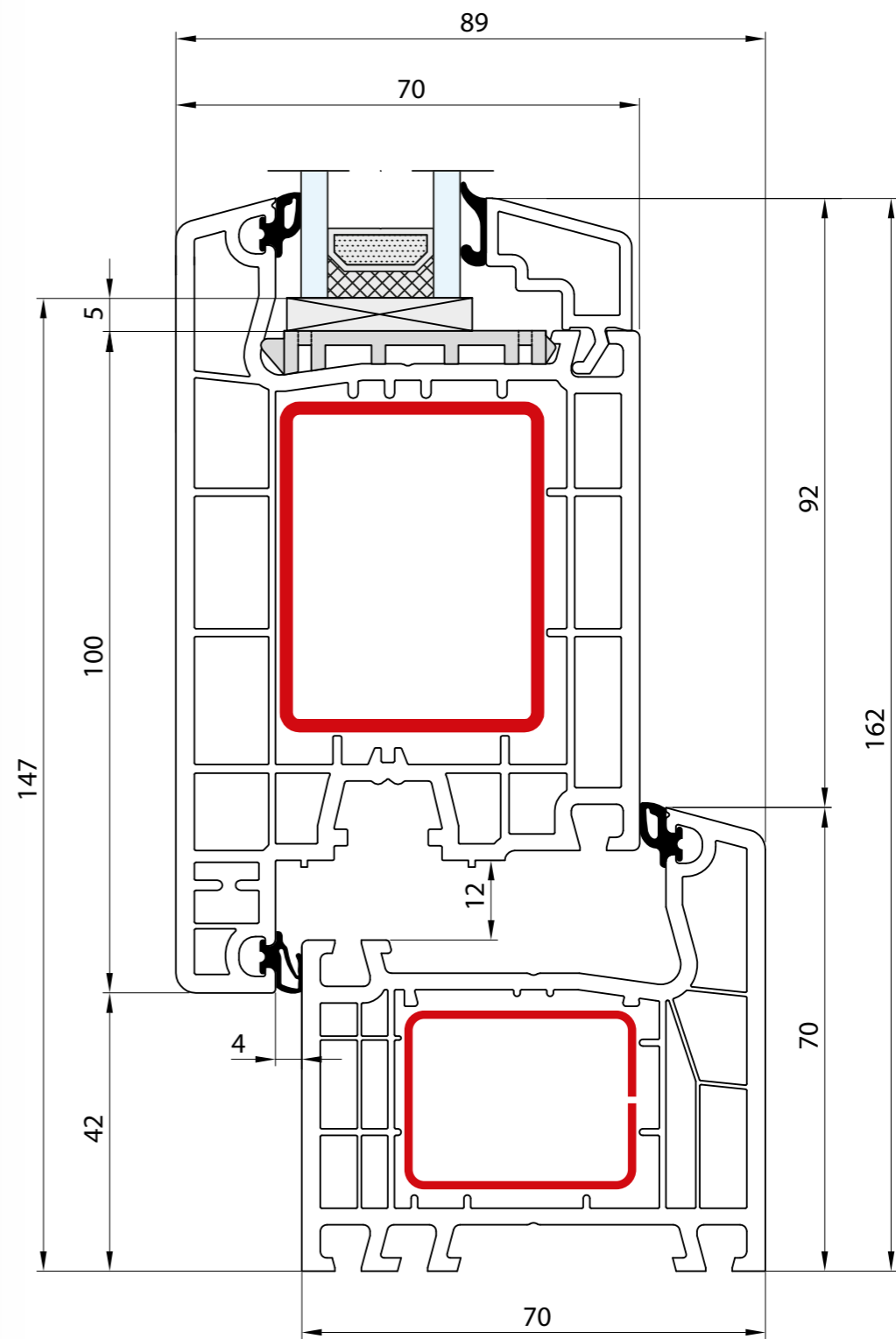

- Rama: 70 mm · Skrzydło: 120 mm
- Dormant: 70 mm · Vantail: 120 mm
- Frame: 70 mm · Sash: 120 mm
- Rahmen: 70 mm · Flügel: 120 mm
- Telaio: 70 mm · Anta: 120 mm

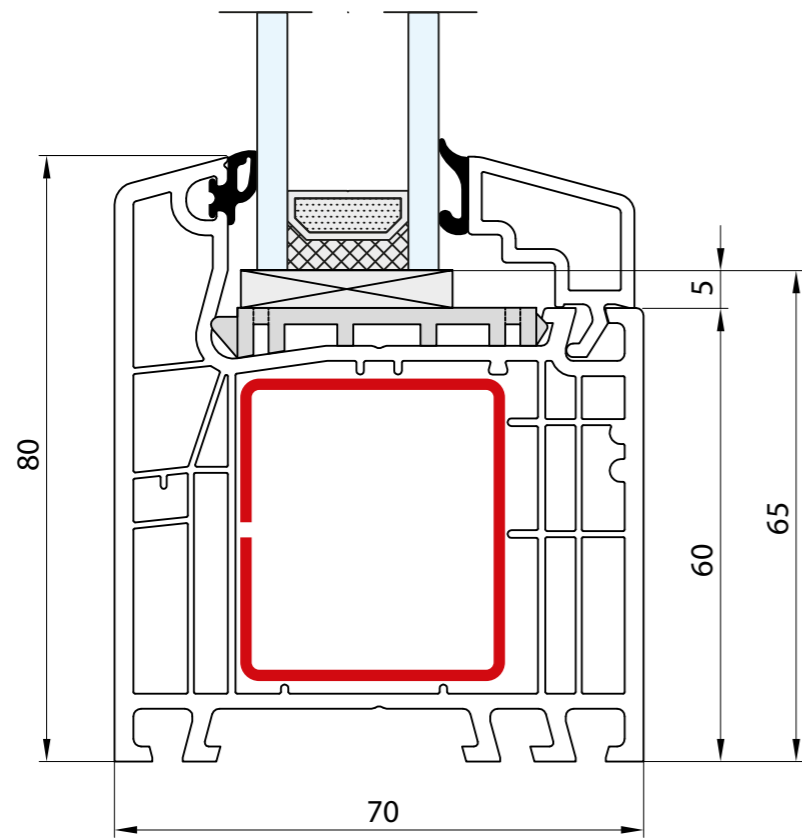

- Rama: 80 mm
- Dormant: 80 mm
- Frame: 80 mm
- Rahmen: 80 mm
- Telaio: 80 mm

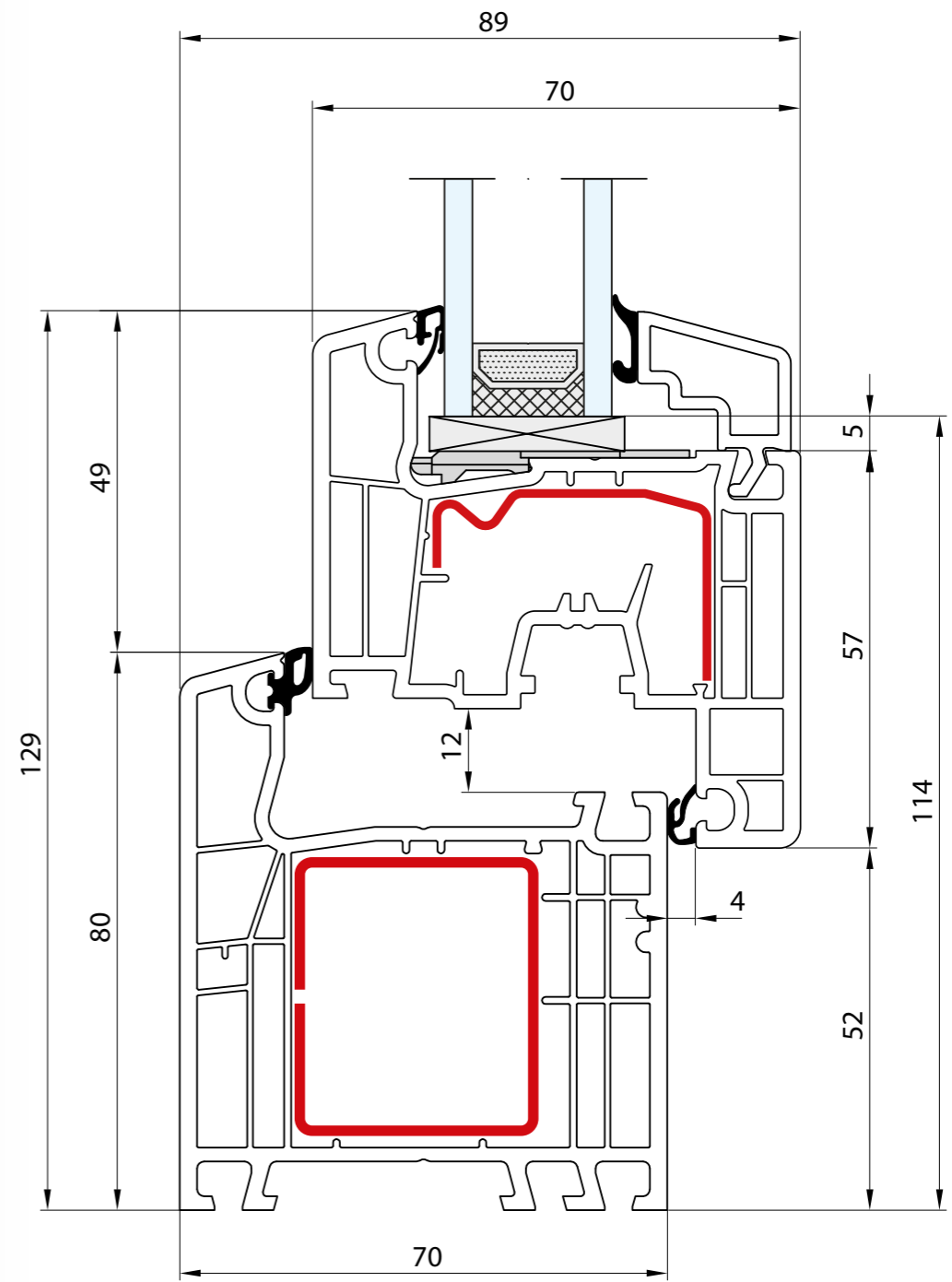
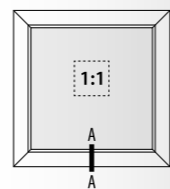

- Rama: 80 mm · Skrzydło: 77 mm
- Dormant: 80 mm · Vantail: 77 mm
- Frame: 80 mm · Sash: 77 mm
- Rahmen: 80 mm · Flügel: 77 mm
- Telaio: 80 mm · Anta: 77 mm

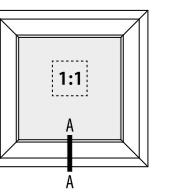

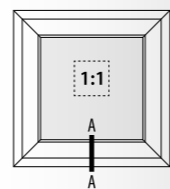
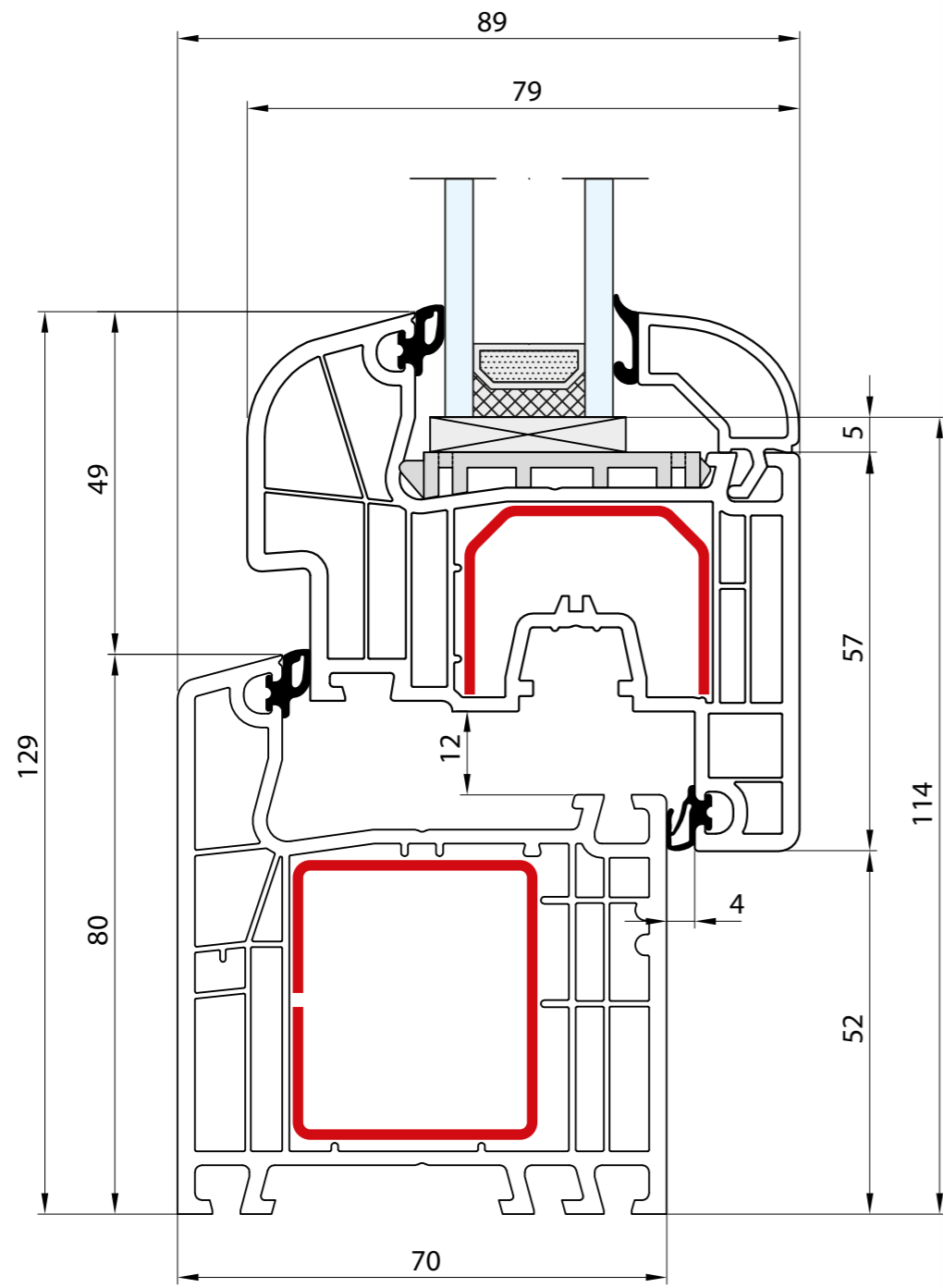

- Rama: 80 mm · Skrzydło: 77 mm
- Dormant: 80 mm · Vantail: 77 mm
- Frame: 80 mm · Sash: 77 mm
- Rahmen: 80 mm · Flügel: 77 mm
- Telaio: 80 mm · Anta: 77 mm

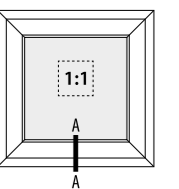
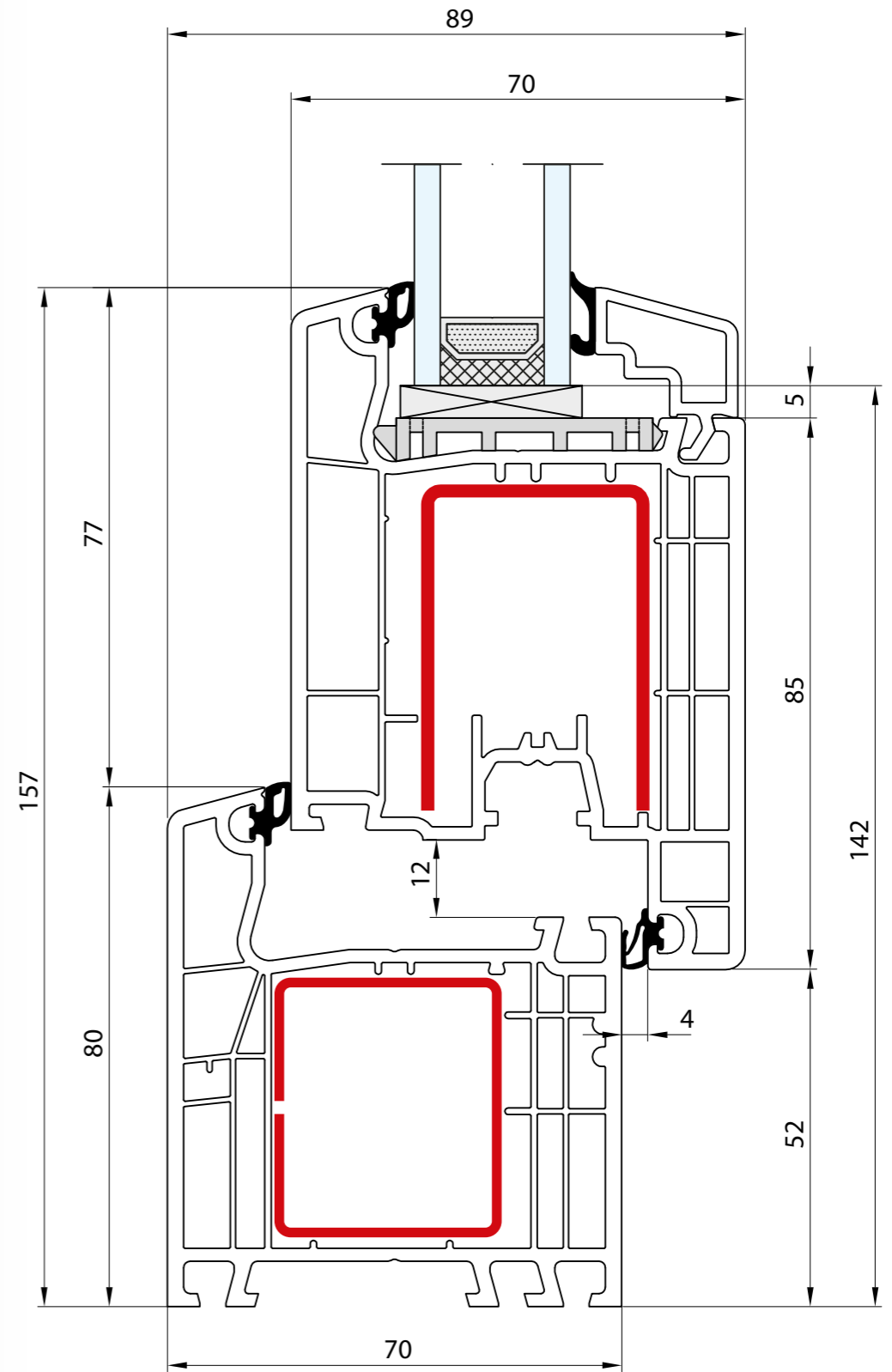

- Rama: 80 mm · Skrzydło: 105 mm
- Dormant: 80 mm · Vantail: 105 mm
- Frame: 80 mm · Sash: 105 mm
- Rahmen: 80 mm · Flügel: 105 mm
- Telaio: 80 mm · Anta: 105 mm

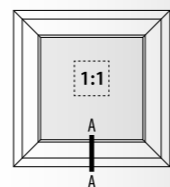
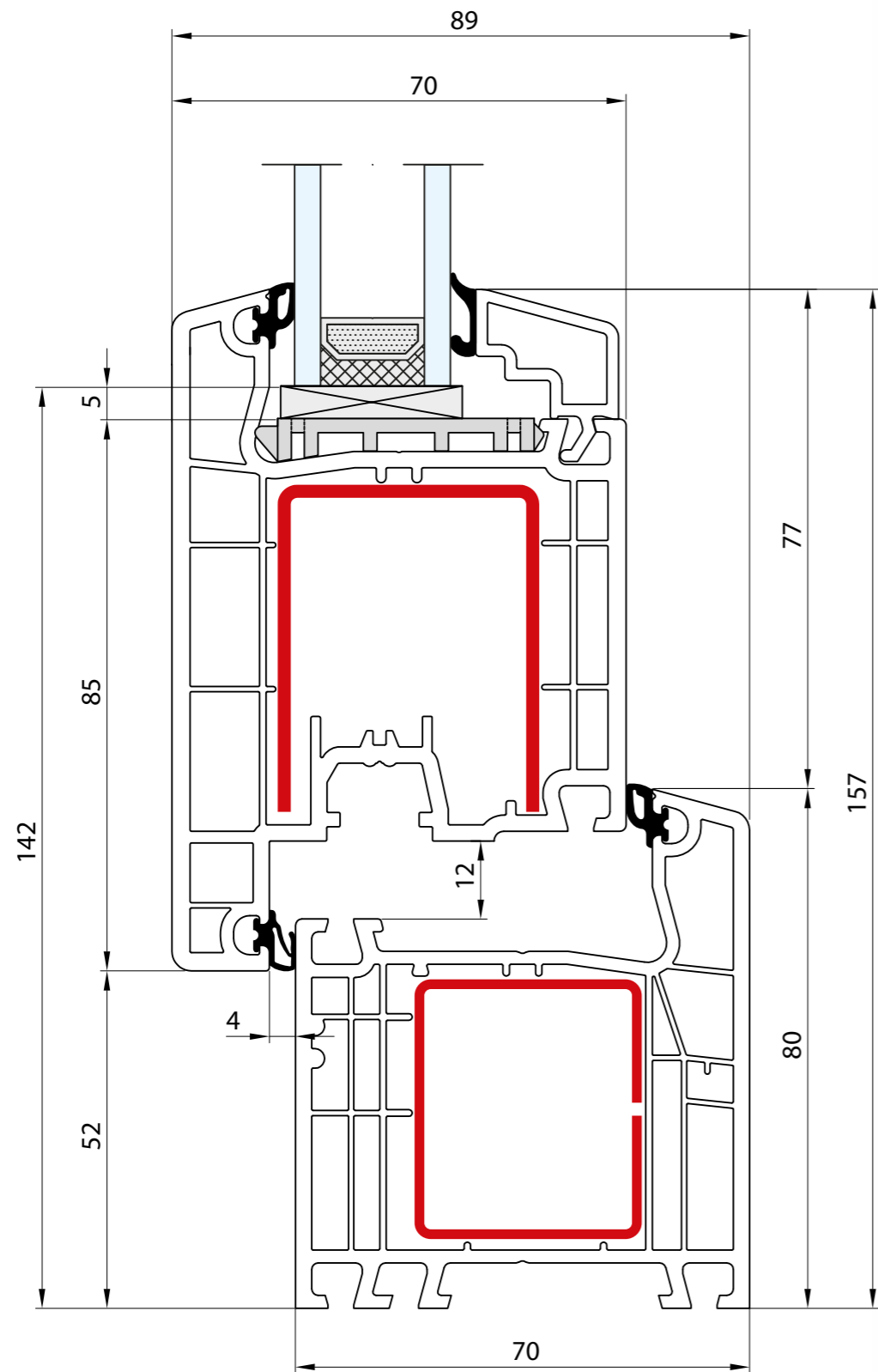

- Rama: 80 mm · Skrzydło: 105 mm
- Dormant: 80 mm · Vantail: 105 mm
- Frame: 80 mm · Sash: 105 mm
- Rahmen: 80 mm · Flügel: 105 mm
- Telaio: 80 mm · Anta: 105 mm

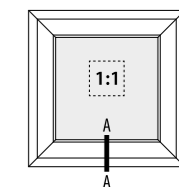
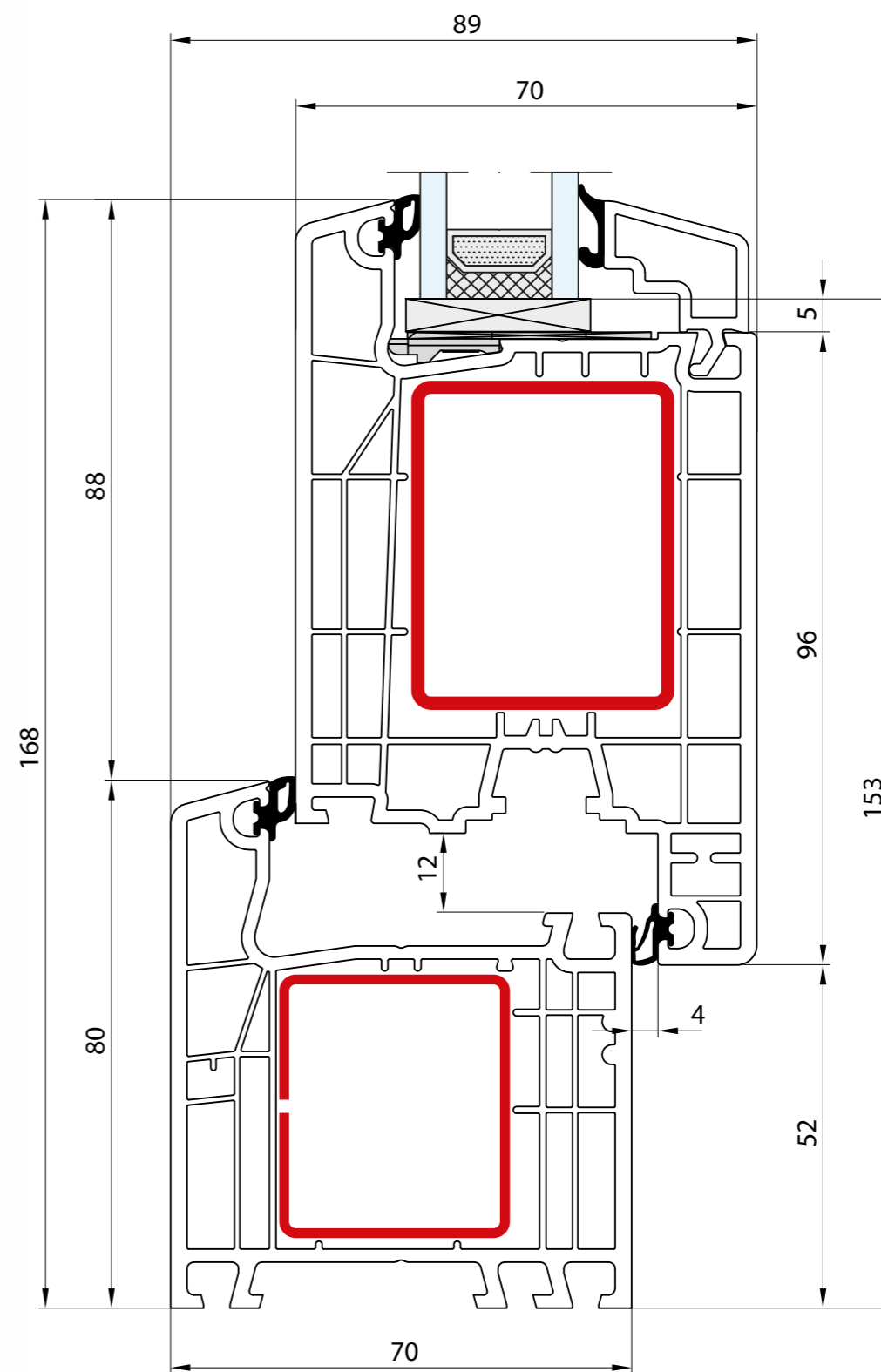

- Rama: 80 mm · Skrzydło: 116 mm
- Dormant: 80 mm · Vantail: 116 mm
- Frame: 80 mm · Sash: 116 mm
- Rahmen: 80 mm · Flügel: 116 mm
- Telaio: 80 mm · Anta: 116 mm

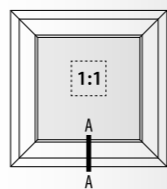
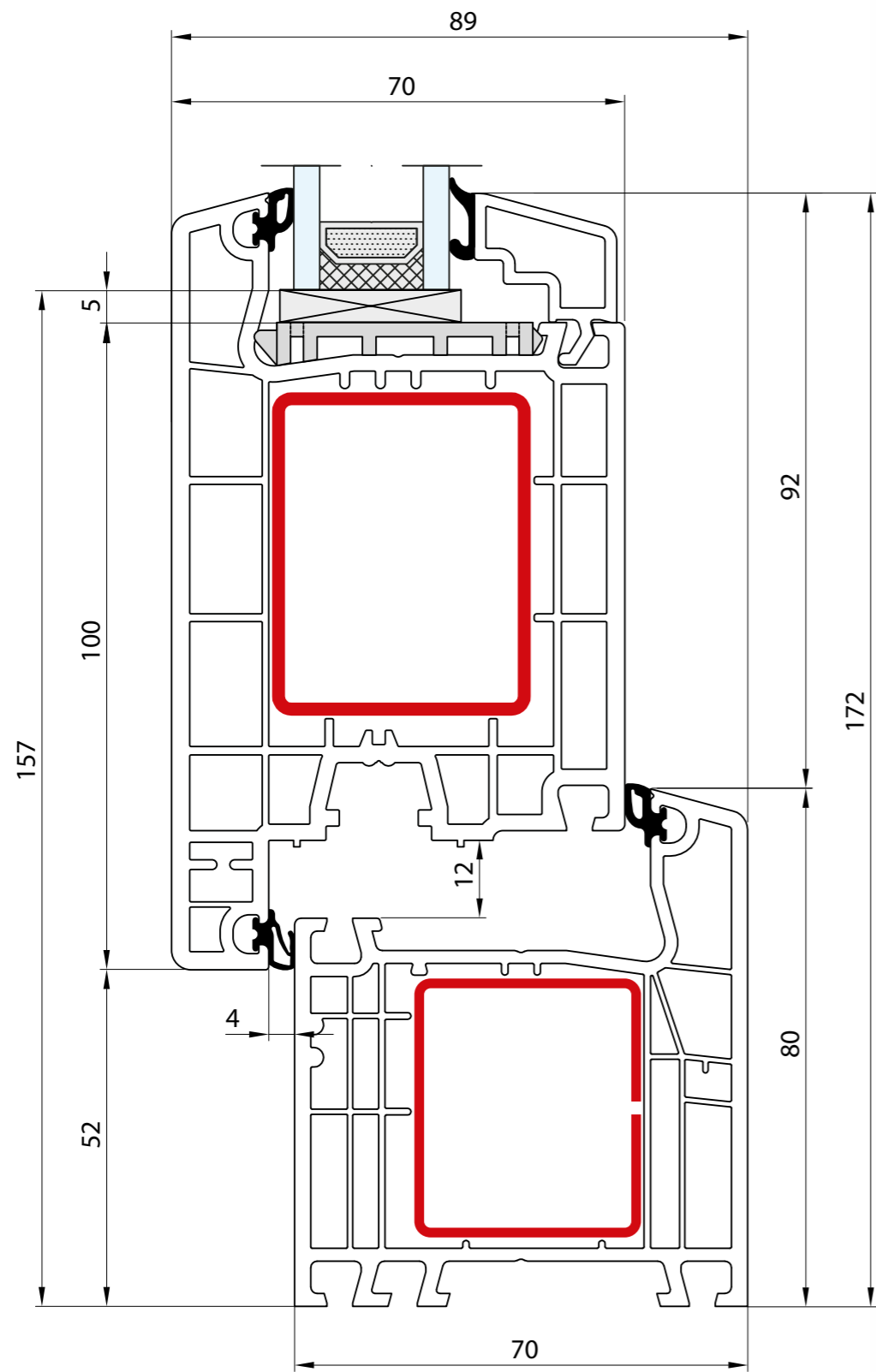

- Rama: 80 mm · Skrzydło: 120 mm
- Dormant: 80 mm · Vantail: 120 mm
- Frame: 80 mm · Sash: 120 mm
- Rahmen: 80 mm · Flügel: 120 mm
- Telaio: 80 mm · Anta: 120 mm

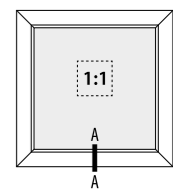
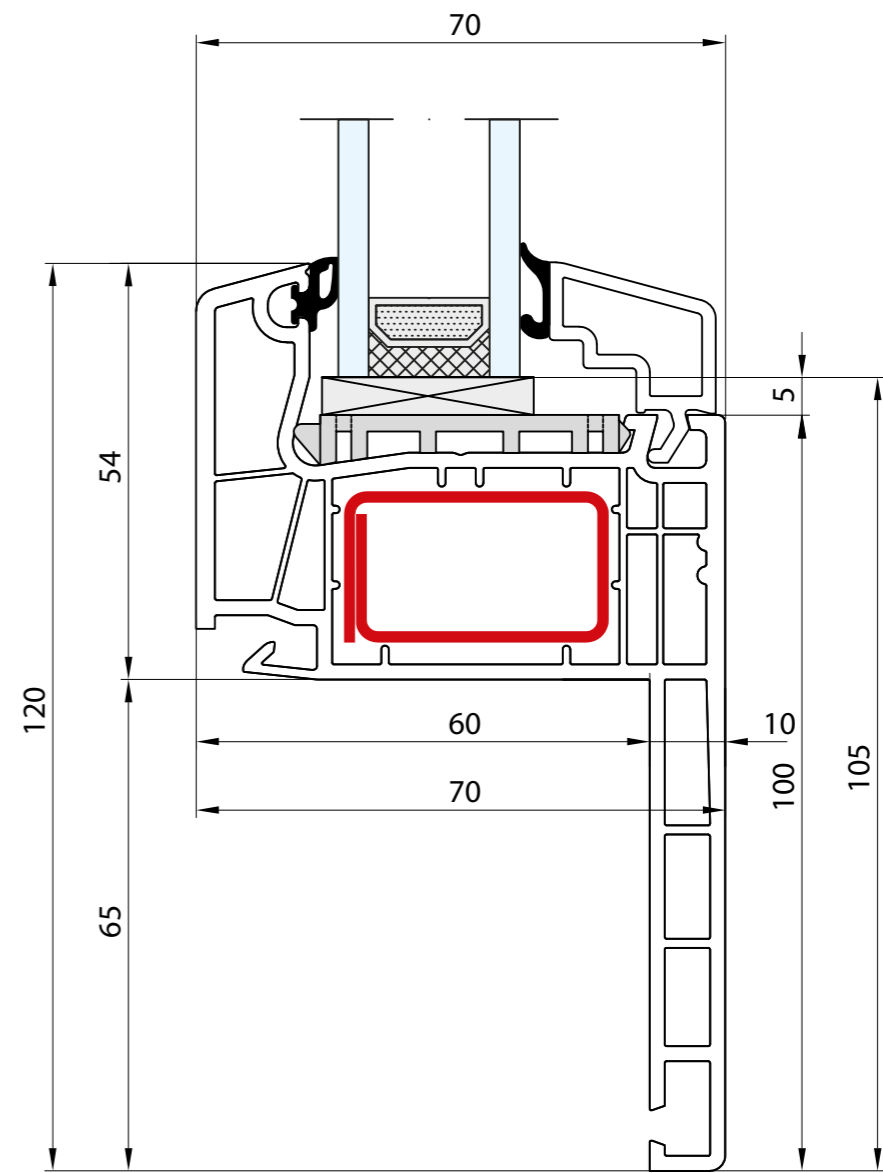

- RENOWACJA - Pletwa: 65 mm · Rama: 54 mm
- RÉNOVATION - Lip: 65 mm · Dormant: 54 mm
- RENOVATION - Strip: 65 mm · Frame: 54 mm
- RENOVIERUNG - Flosse: 65 mm · Rahmen: 54 mm
- RINNOVAZIONE - Aletta da: 65 mm · Telaio: 54 mm

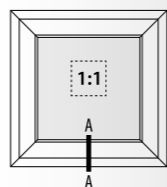
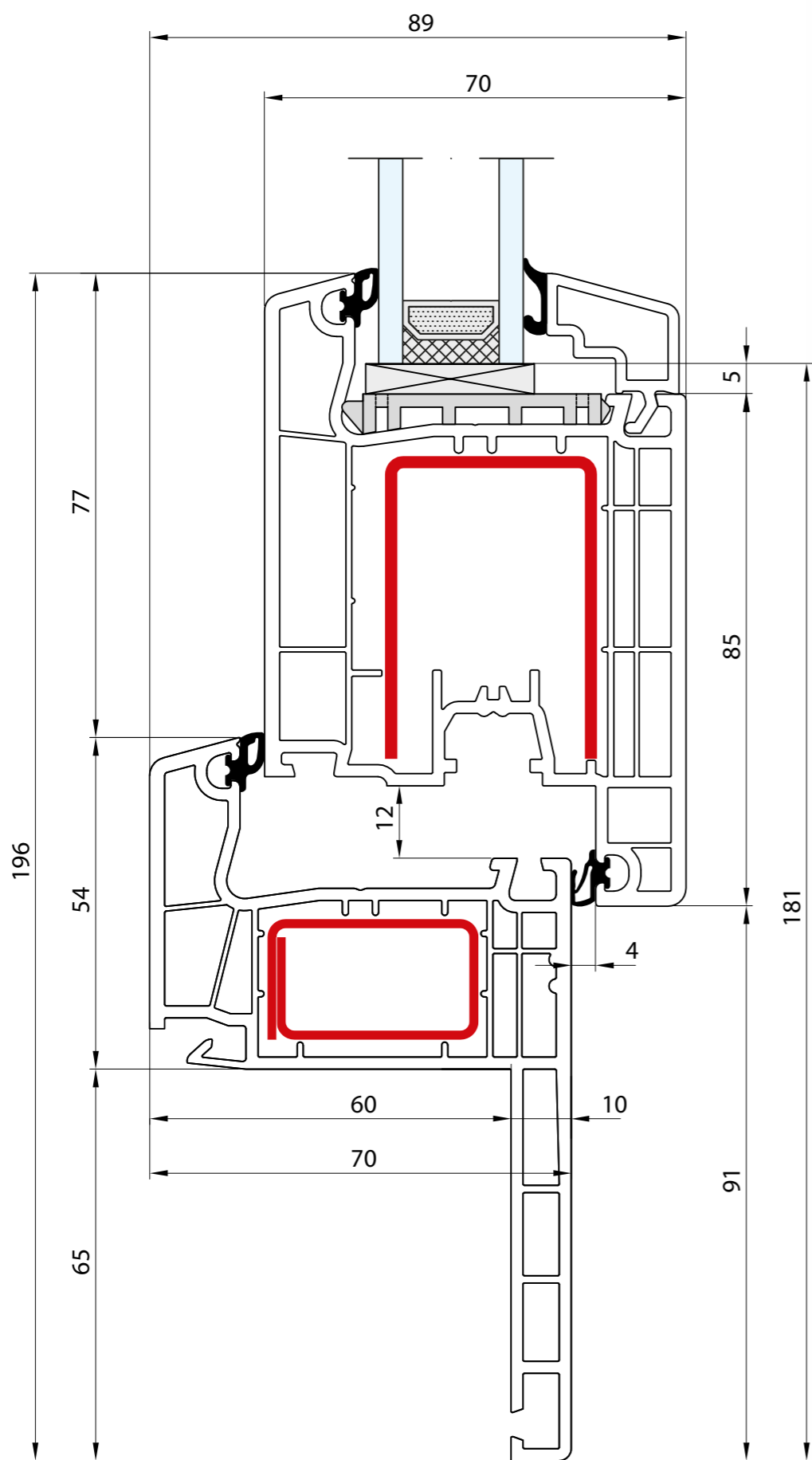

- RENOWACJA - Pletwa: 65 mm · Rama: 54 mm · Skrzydło: 105 mm
- RÉNOVATION - Lip: 65 mm · Dormant: 54 mm · Vantail: 105 mm
- RENOVATION - Strip: 65 mm · Frame: 54 mm · Sash: 105 mm
- RENOVIERUNG - Flosse: 65 mm · Rahmen: 54 mm · Flügel: 105 mm
- RINNOVAZIONE - Aletta da: 65 mm · Telaio: 54 mm · Anta: 105 mm

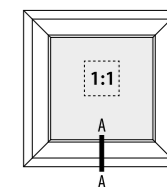
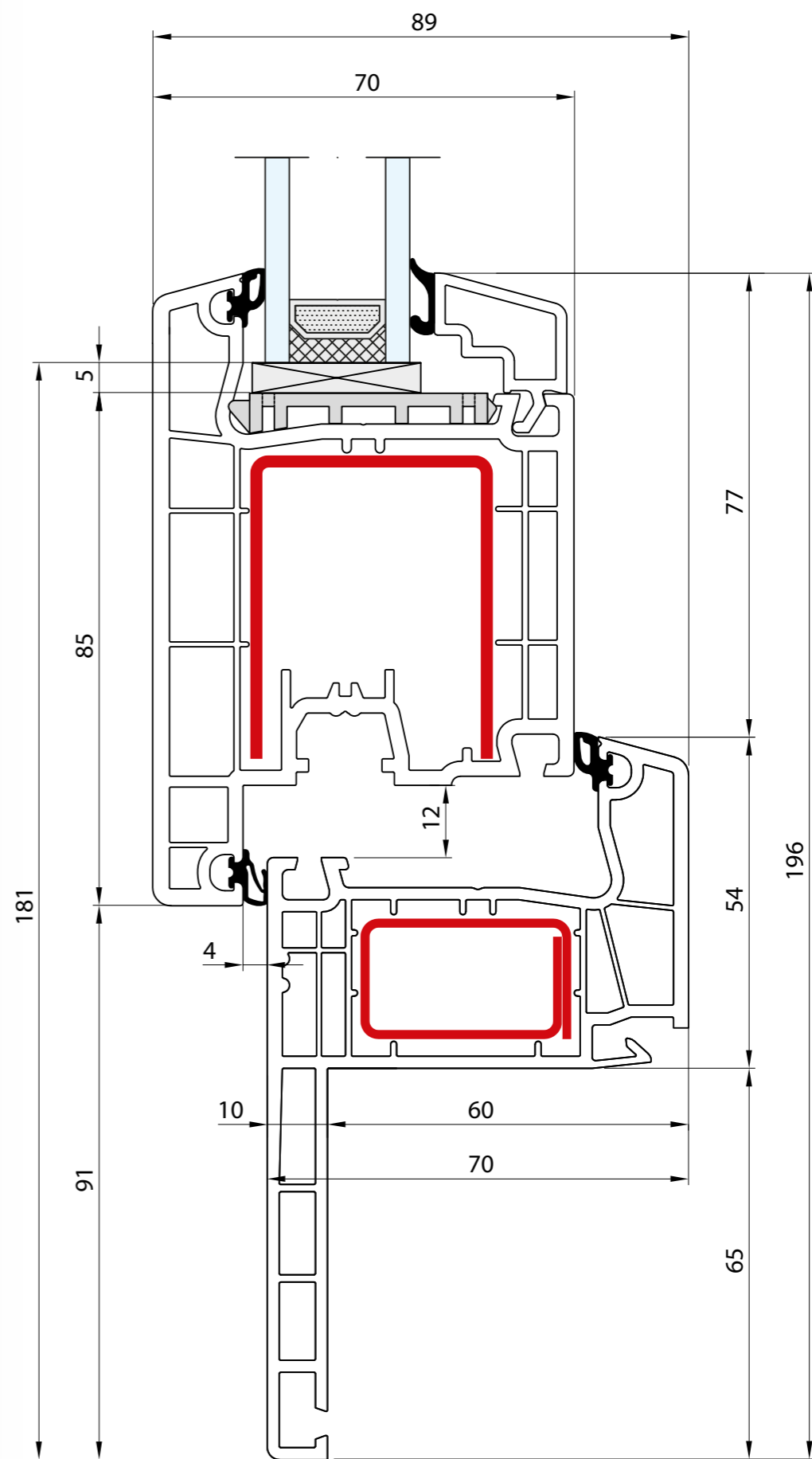

- RENOWACJA - Pletwa: 65 mm · Rama: 54 mm · Skrzydło: 105 mm
- RÉNOVATION - Lip: 65 mm · Dormant: 54 mm · Vantail: 105 mm
- RENOVATION - Strip: 65 mm · Frame: 54 mm · Sash: 105 mm
- RENOVIERUNG - Flosse: 65 mm · Rahmen: 54 mm · Flügel: 105 mm
- RINNOVAZIONE - Aletta da: 65 mm · Telaio: 54 mm · Anta: 105 mm

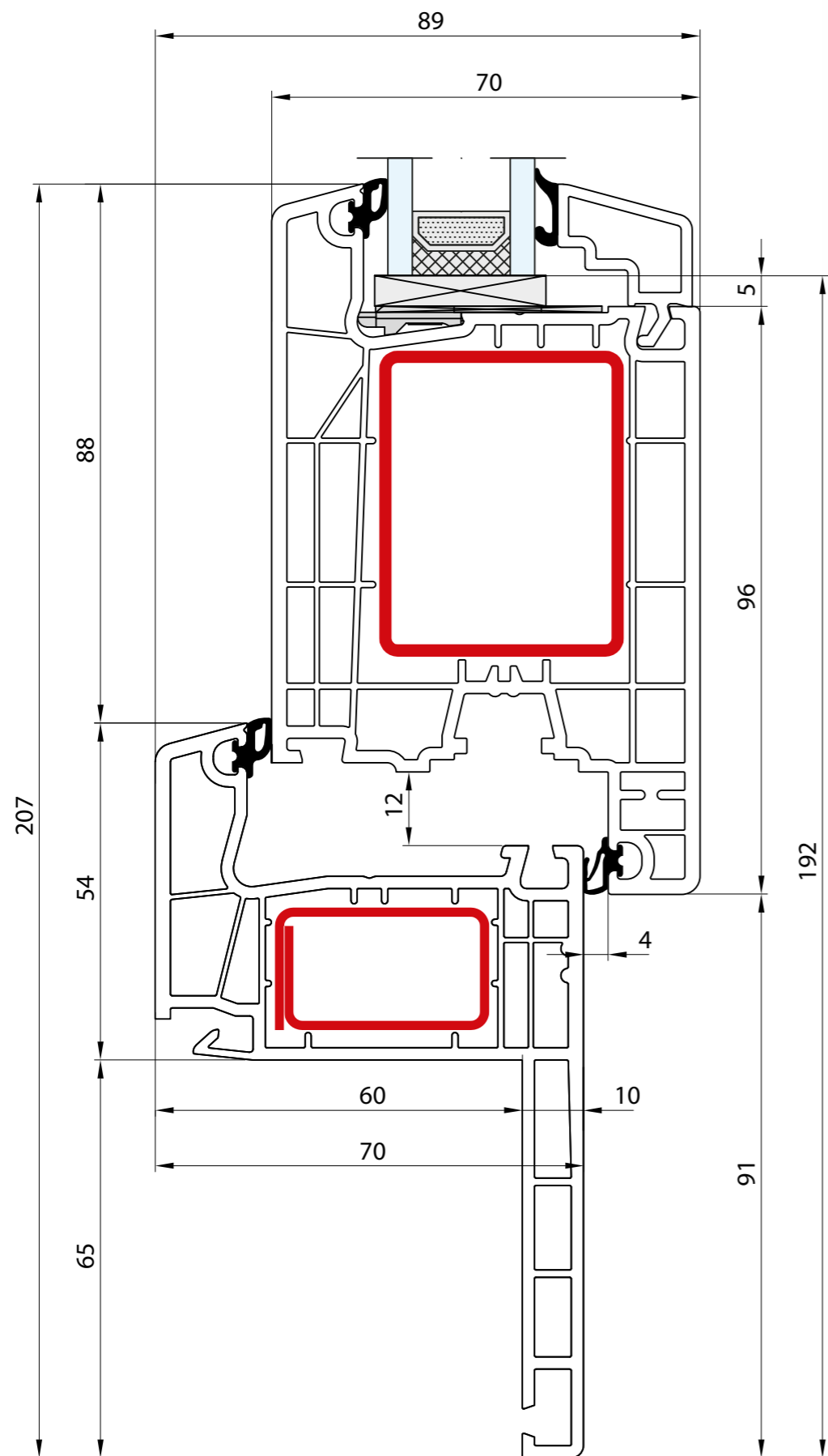

- RENOWACJA - Pletwa: 65 mm · Rama: 54 mm · Skrzydło: 116 mm
- RÉNOVATION - Lip: 65 mm · Dormant: 54 mm · Vantail: 116 mm
- RENOVATION - Strip: 65 mm · Frame: 54 mm · Sash: 116 mm
- RENOVIERUNG - Flosse: 65 mm · Rahmen: 54 mm · Flügel: 116 mm
- RINNOVAZIONE - Aletta da: 65 mm · Telaio: 54 mm · Anta: 116 mm

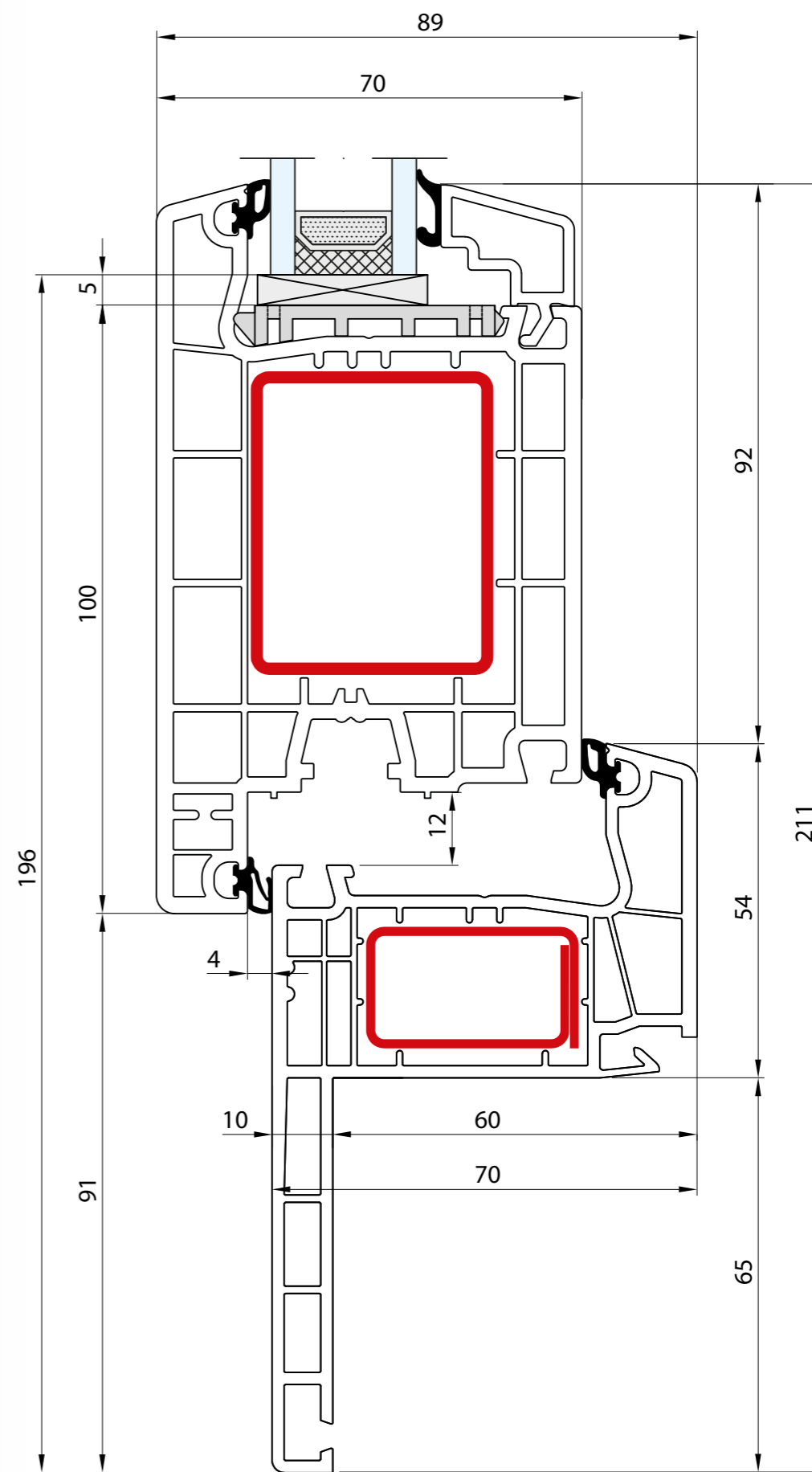
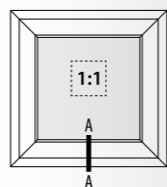

- RENOWACJA - Pletwa: 65 mm · Rama: 54 mm · Skrzydło: 105 mm
- RÉNOVATION - Lip: 65 mm · Dormant: 54 mm · Vantail: 105 mm
- RENOVATION - Strip: 65 mm · Frame: 54 mm · Sash: 105 mm
- RENOVIERUNG - Flosse: 65 mm · Rahmen: 54 mm · Flügel: 105 mm
- RINNOVAZIONE - Aletta da: 65 mm · Telaio: 54 mm · Anta: 105 mm

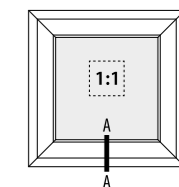

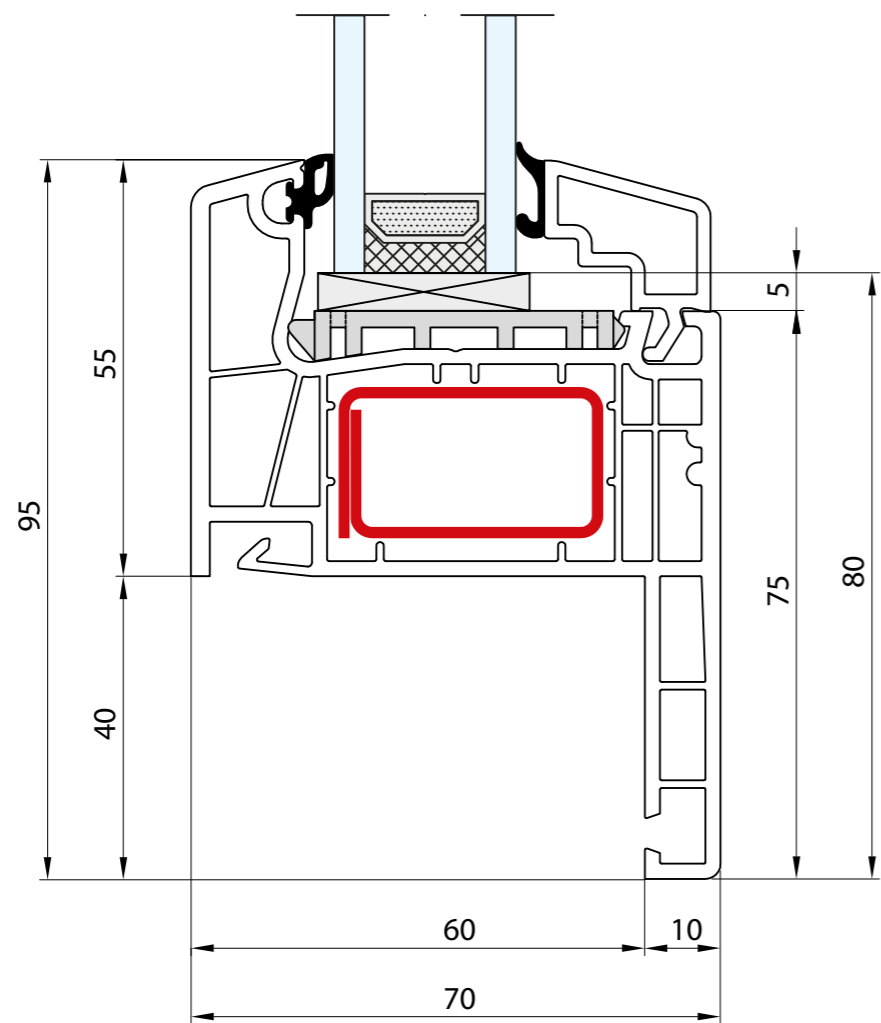

- RENOWACJA - Pletwa: 40 mm · Rama: 55 mm
- RÉNOVATION - Lip: 40 mm · Dormant: 55 mm
- RENOVATION - Strip: 40 mm · Frame: 55 mm
- RENOVIERUNG - Flosse: 40 mm · Rahmen: 55 mm
- RINNOVAZIONE - Aletta da: 40 mm · Telaio: 55 mm

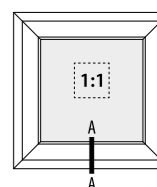
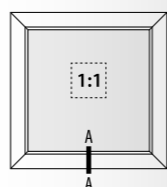

A

A

1:1

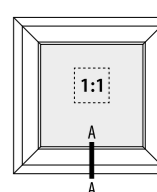

A

1:1

1:1

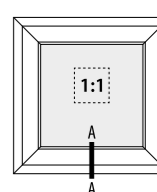

A

1:1

1:1

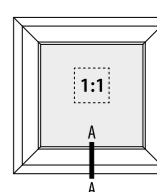

A

1:1

1:1

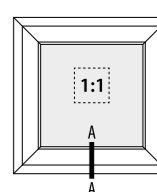

A

1:1

1:1

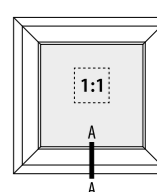

A

1:1

1:1

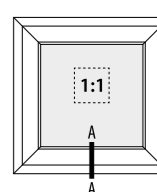

A

1:1

1:1

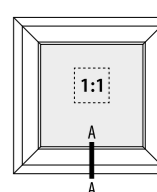

A

1:1

1:1

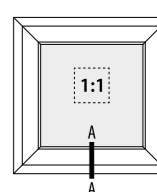

A

1:1

1:1

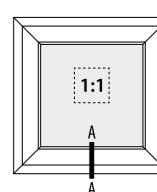

A

1:1

1:1

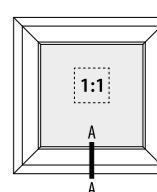

A

1:1

1:1

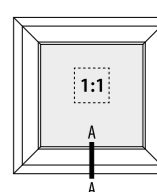

A

1:1

1:1

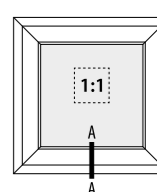

A

1:1

1:1

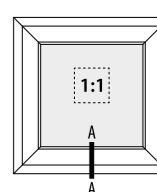

A

1:1

1:1

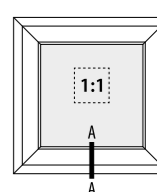

A

1:1

1:1

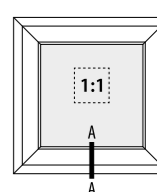

A

1:1

1:1

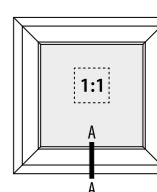

A

1:1

1:1

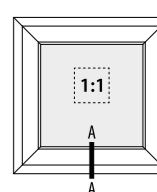

A

1:1

1:1

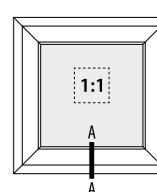

A

1:1

1:1

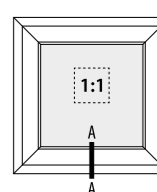

A

1:1

1:1

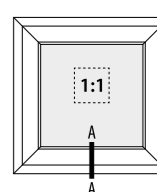

A

1:1

1:1

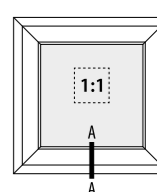

A

1:1

1:1

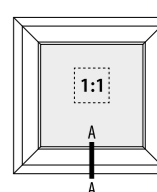

A

1:1

1:1

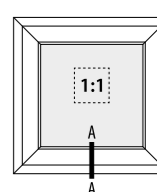

A

1:1

1:1

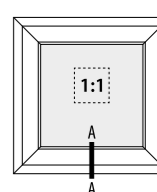

A

1:1

1:1

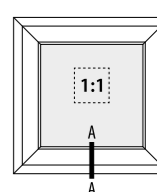

A

1:1

1:1

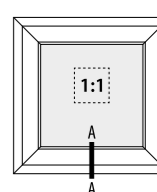

A

1:1

1:1

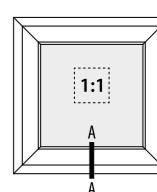

A

1:1

1:1

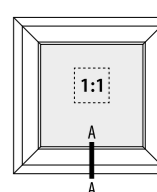

A

1:1

1:1

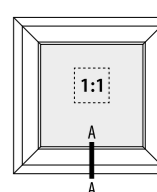

A

1:1

1:1

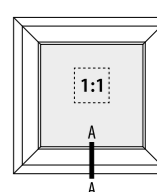

A

1:1

1:1

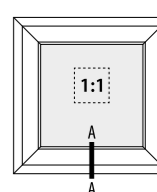

A

1:1

1:1

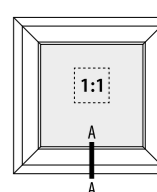

A

1:1

1:1

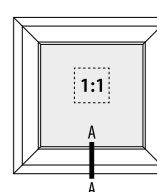

A

1:1

1:1

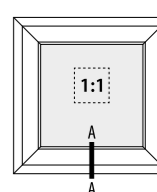

A

1:1

1:1

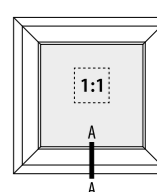

A

1:1

1:1

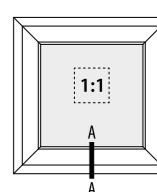

A

1:1

1:1

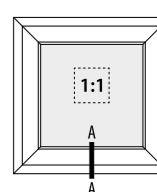

A

1:1

1:1

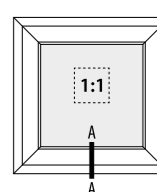

A

1:1

1:1

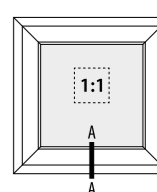

A

1:1

1:1

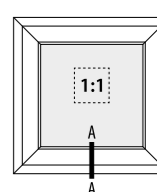

A

1:1

1:1

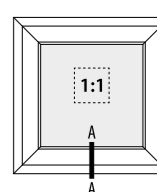

A

1:1

1:1

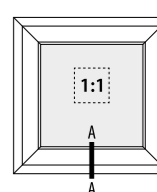

A

1:1

1:1

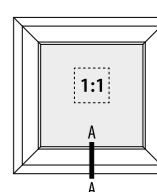

A

1:1

1:1

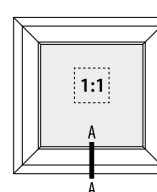

A

1:1

1:1

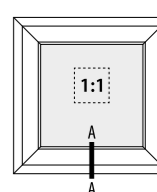

A

1:1

1:1

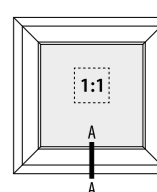

A

1:1

1:1

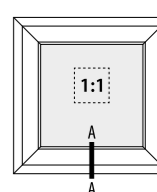

A

1:1

1:1

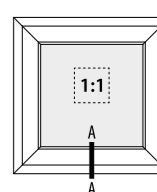

A

1:1

1:1

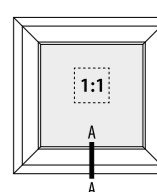

A

1:1

1:1

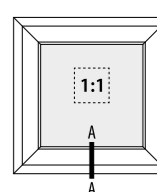

A

1:1

1:1

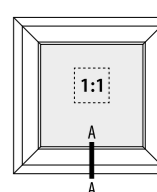

A

1:1

1:1

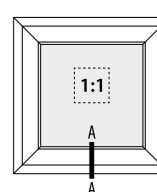

A

1:1

1:1

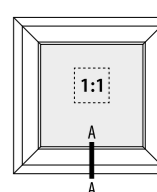

A

1:1

1:1

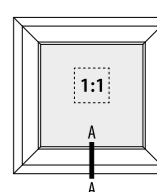

A

1:1

1:1

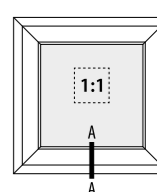

A

1:1

1:1

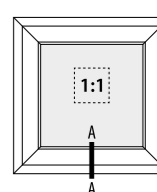

A

1:1

1:1

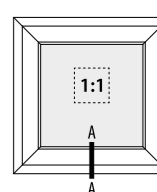

A

1:1

1:1

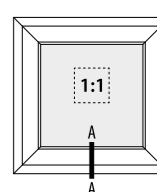

A

1:1

1:1

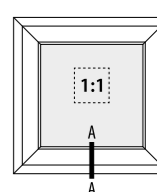

A

1:1

1:1

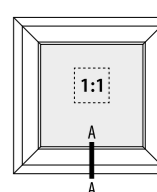

A

1:1

1:1

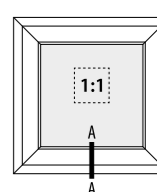

A

1:1

1:1

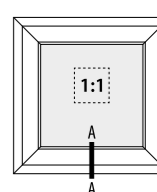

A

1:1

1:1

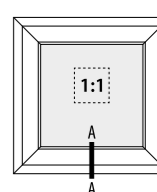

A

1:1

1:1

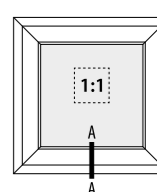

A

1:1

1:1

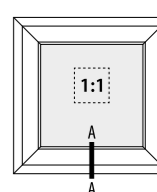

A

1:1

1:1

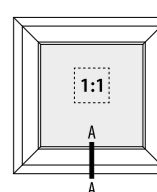

A

1:1

1:1

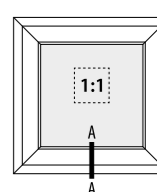

A

1:1

1:1

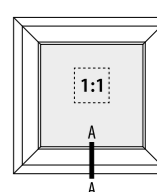

A

1:1

1:1

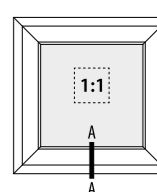

A

1:1

1:1

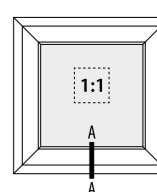

A

1:1

1:1

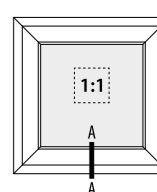

A

1:1

1:1

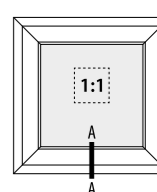

A

1:1

1:1

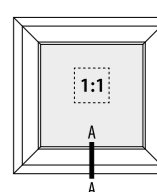

A

1:1

1:1

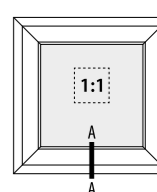

A

1:1

1:1

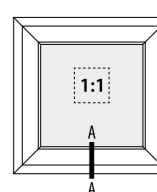

A

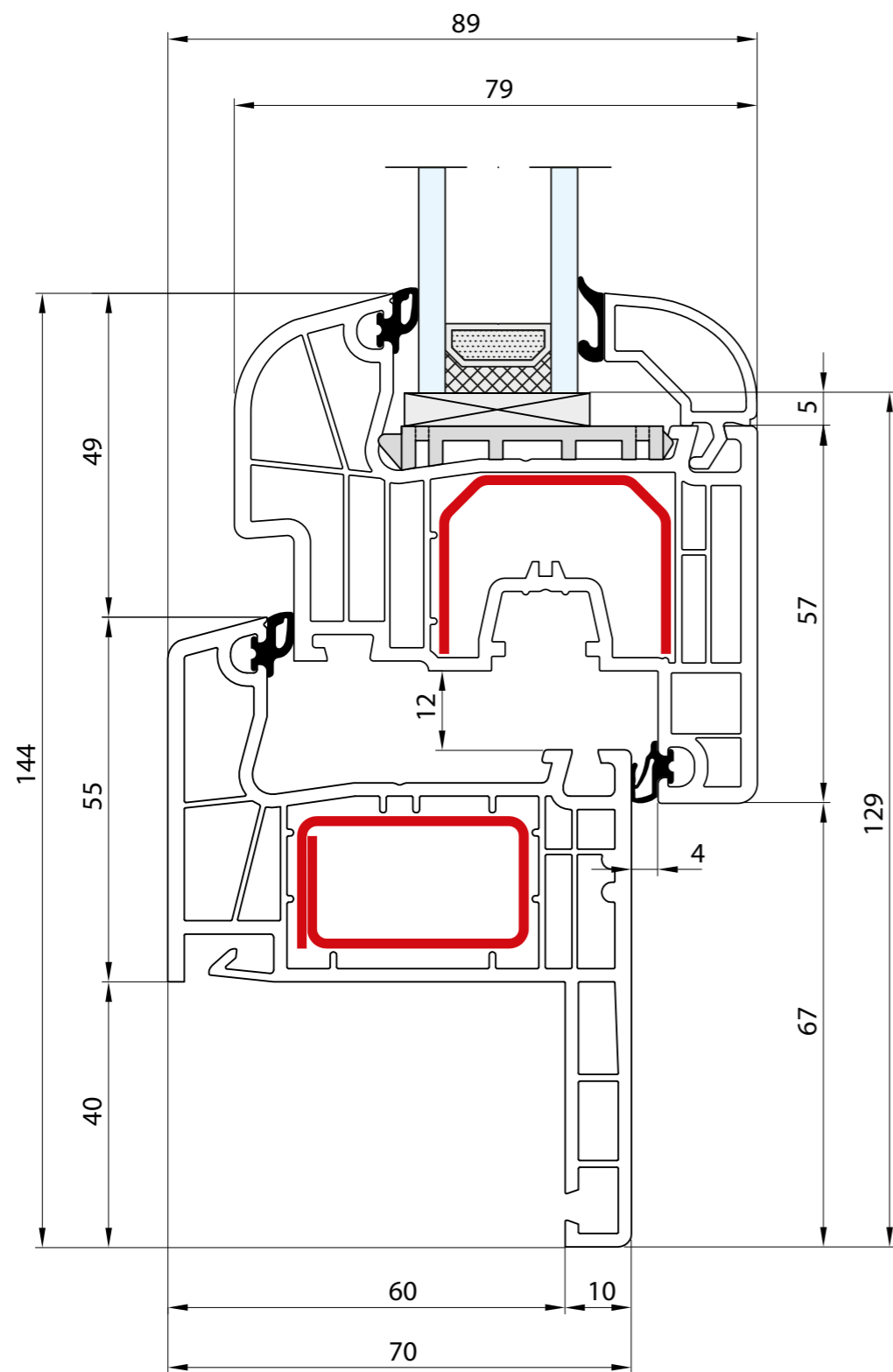

- RENOWACJA - Pletwa: 40 mm · Rama: 55 mm · Skrzydło: 77 mm
- RÉNOVATION - Lip: 40 mm · Dormant: 55 mm · Vantail: 77 mm
- RENOVATION - Strip: 40 mm · Frame: 55 mm · Sash: 77 mm
- RENOVIERUNG - Flosse: 40 mm · Rahmen: 55 mm · Flügel: 77 mm
- RINNOVAZIONE - Aletta da: 40 mm · Telaio: 55 mm · Anta: 77 mm

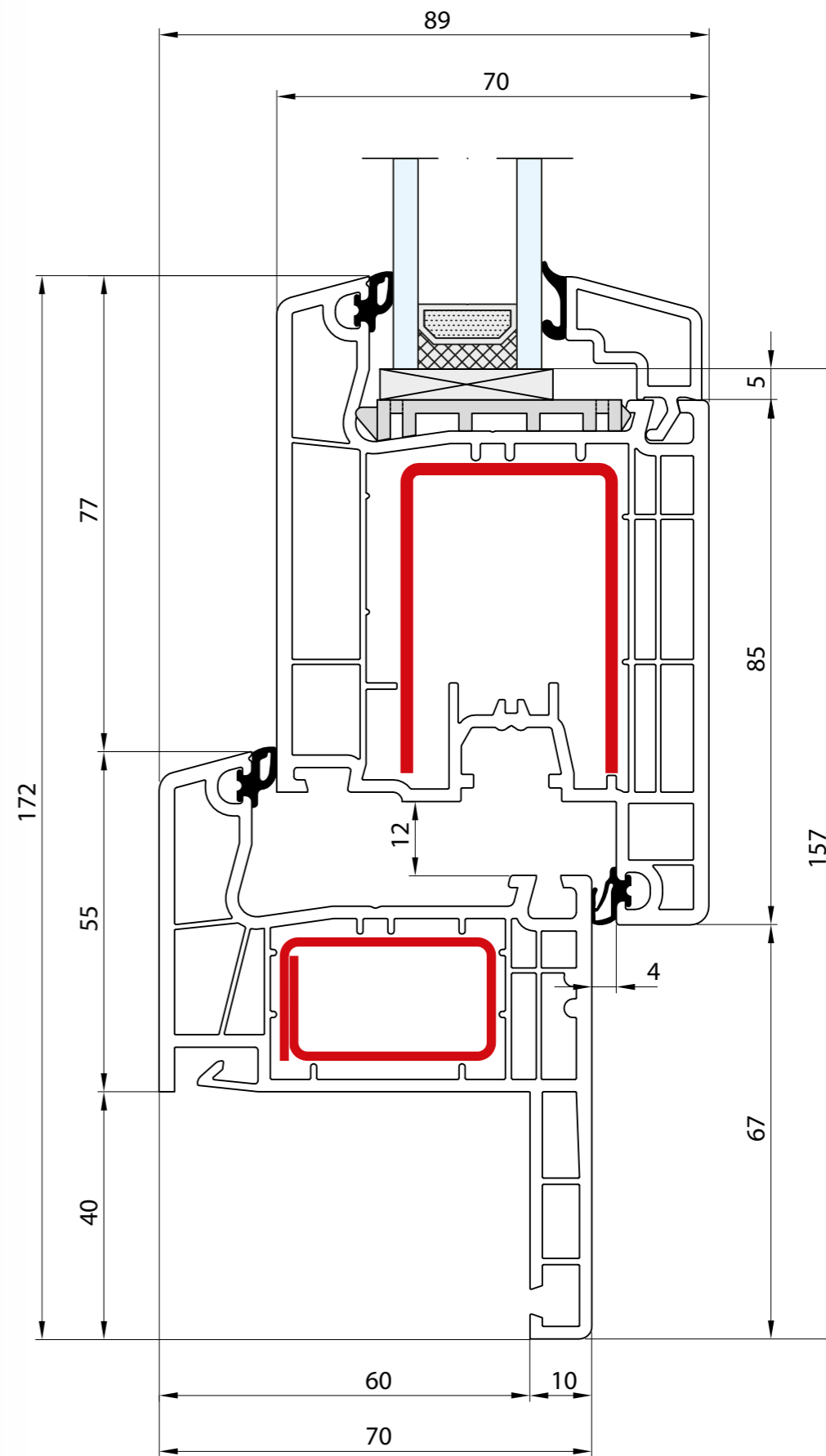
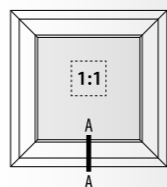

- RENOWACJA - Pletwa: 40 mm · Rama: 55 mm · Skrzydło: 105 mm
- RÉNOVATION - Lip: 40 mm · Dormant: 55 mm · Vantail: 105 mm
- RENOVATION - Strip: 40 mm · Frame: 55 mm · Sash: 105 mm
- RENOVIERUNG - Flosse: 40 mm · Rahmen: 55 mm · Flügel: 105 mm
- RINNOVAZIONE - Aletta da: 40 mm · Telaio: 55 mm · Anta: 105 mm

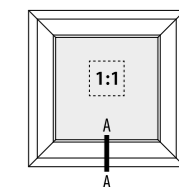

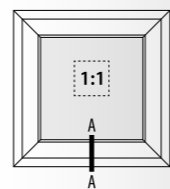
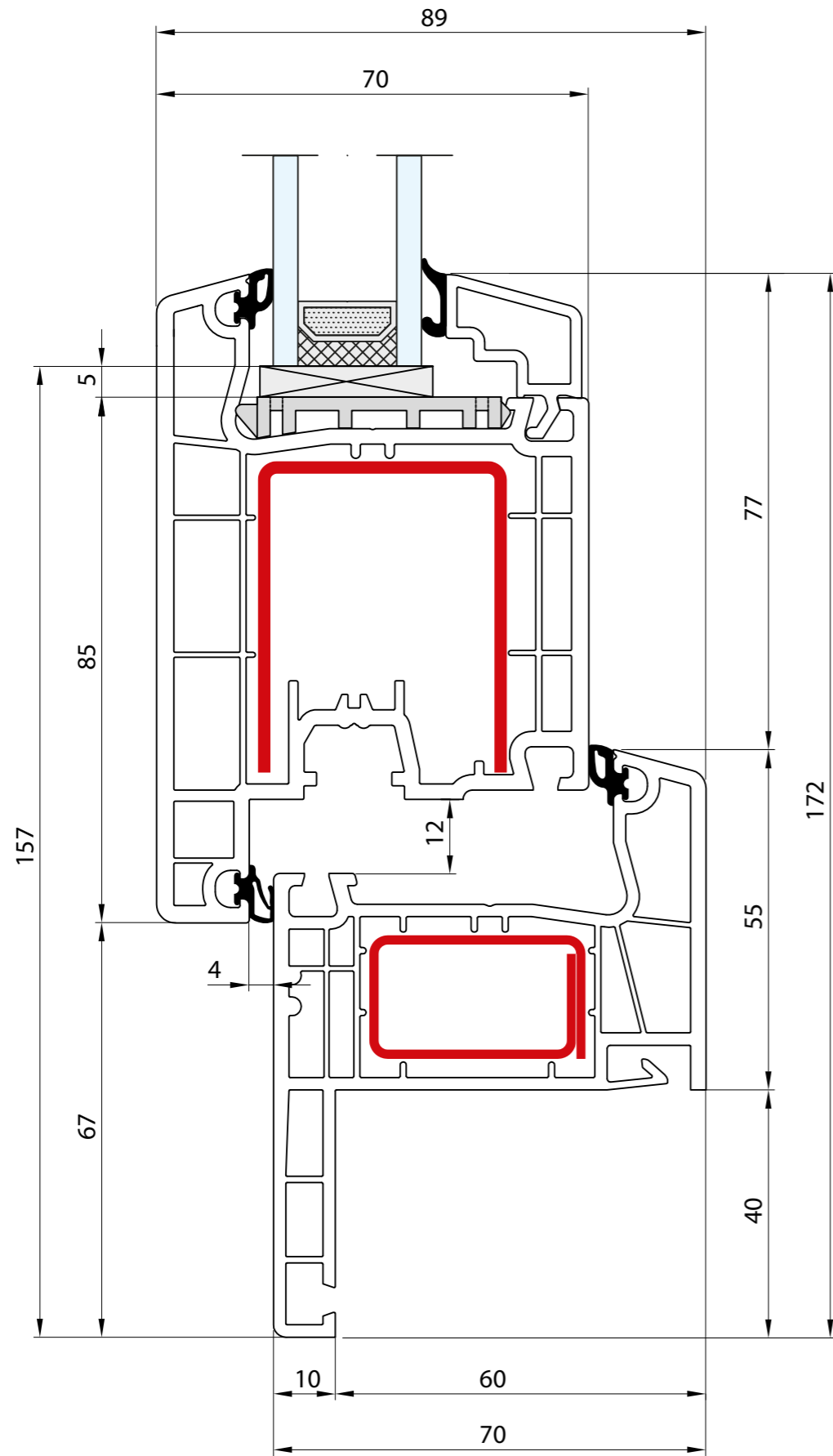
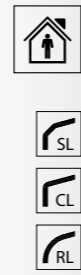

- RENOWACJA - Pletwa: 40 mm · Rama: 55 mm · Skrzydło: 105 mm
- RÉNOVATION - Lip: 40 mm · Dormant: 55 mm · Vantail: 105 mm
- RENOVATION - Strip: 40 mm · Frame: 55 mm · Sash: 105 mm
- RENOVIERUNG - Flosse: 40 mm · Rahmen: 55 mm · Flügel: 105 mm
- RINNOVAZIONE - Aletta da: 40 mm · Telaio: 55 mm · Anta: 105 mm

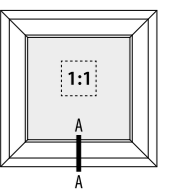
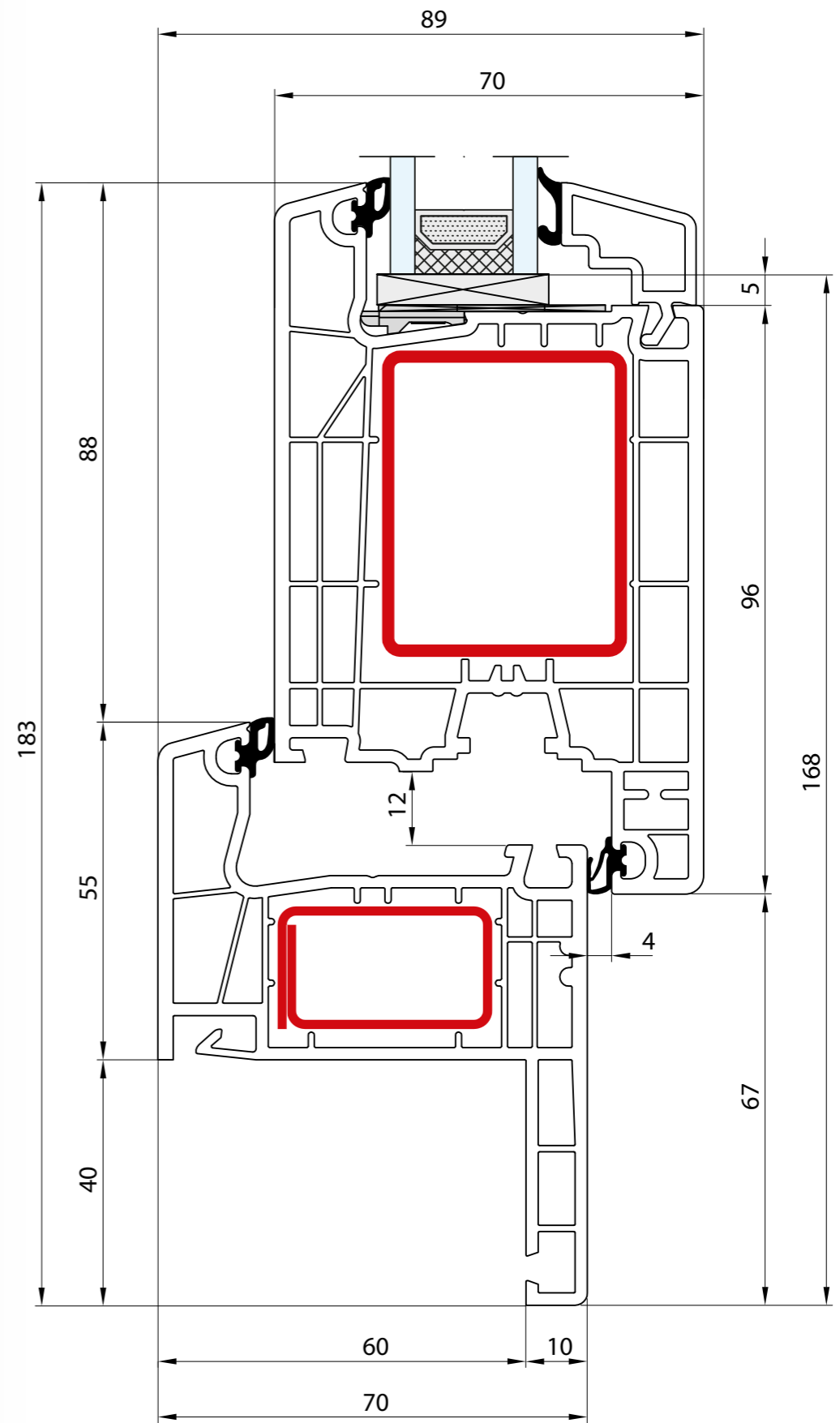

- RENOWACJA - Pletwa: 40 mm · Rama: 55 mm · Skrzydło: 116 mm
- RÉNOVATION - Lip: 40 mm · Dormant: 55 mm · Vantail: 116 mm
- RENOVATION - Strip: 40 mm · Frame: 55 mm · Sash: 116 mm
- RENOVIERUNG - Flosse: 40 mm · Rahmen: 55 mm · Flügel: 116 mm
- RINNOVAZIONE - Aletta da: 40 mm · Telaio: 55 mm · Anta: 116 mm

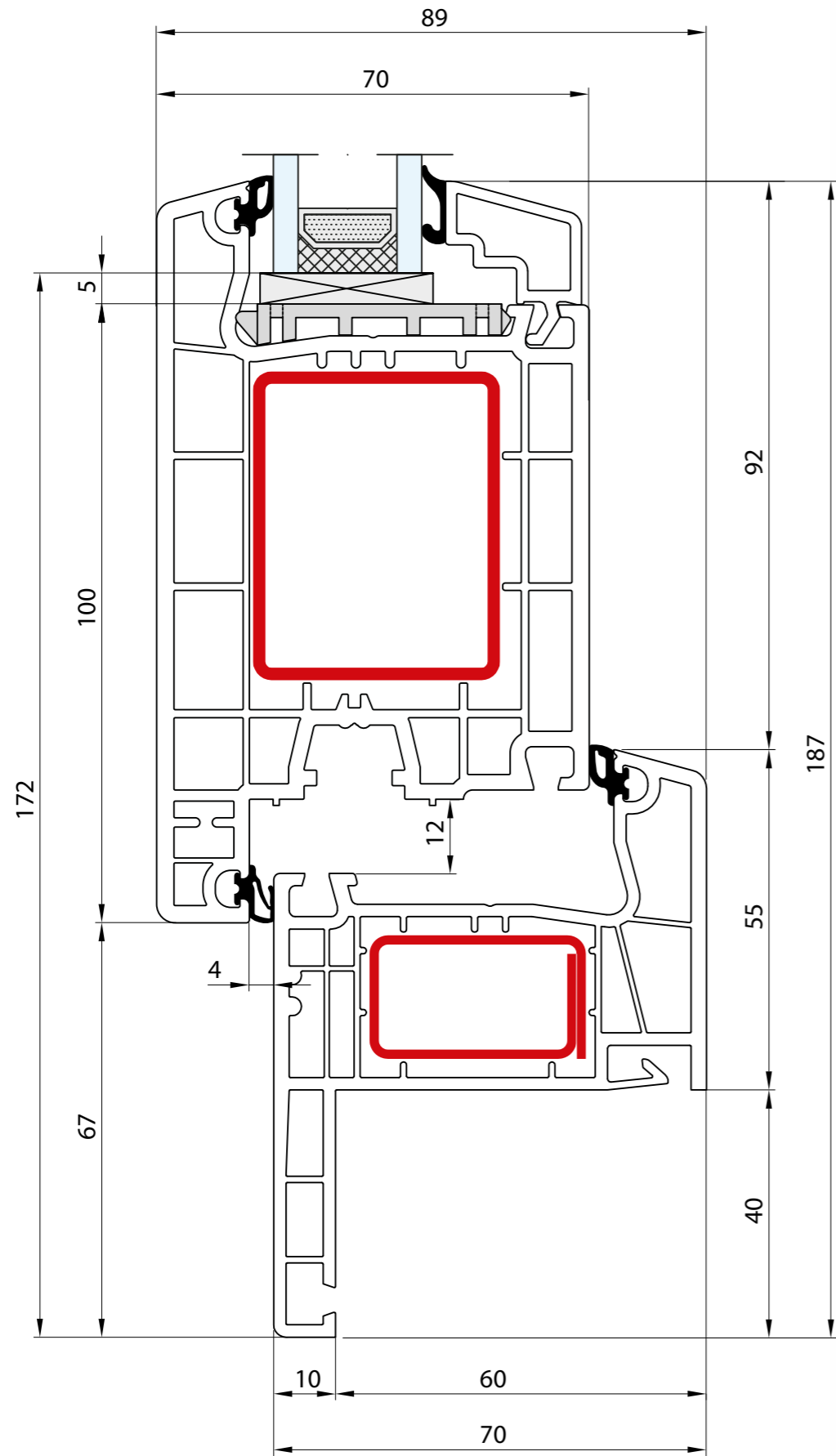

- RENOWACJA - Pletwa: 40 mm · Rama: 55 mm · Skrzydło: 120 mm
- RÉNOVATION - Lip: 40 mm · Dormant: 55 mm · Vantail: 120 mm
- RENOVATION - Strip: 40 mm · Frame: 55 mm · Sash: 120 mm
- RENOVIERUNG - Flosse: 40 mm · Rahmen: 55 mm · Flügel: 120 mm
- RINNOVAZIONE - Aletta da: 40 mm · Telaio: 55 mm · Anta: 120 mm

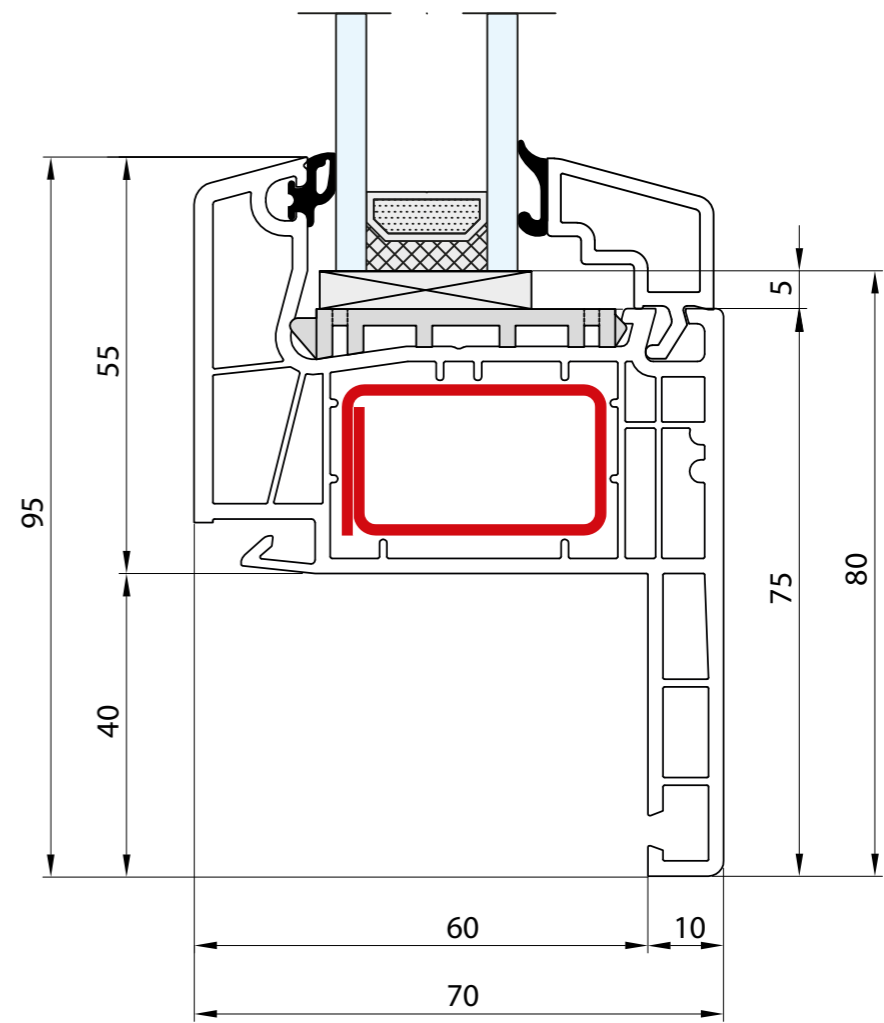
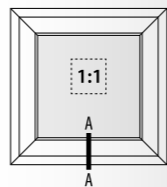

- RENOWACJA - Pletwa: 40 mm · Rama: 55 mm
- RÉNOVATION - Lip: 40 mm · Dormant: 55 mm
- RENOVATION - Strip: 40 mm · Frame: 55 mm
- RENOVIERUNG - Flosse: 40 mm · Rahmen: 55 mm
- RINNOVAZIONE - Aletta da: 40 mm · Telaio: 55 mm

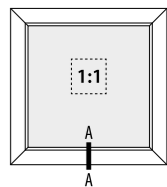

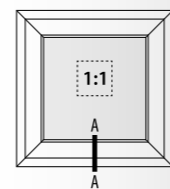
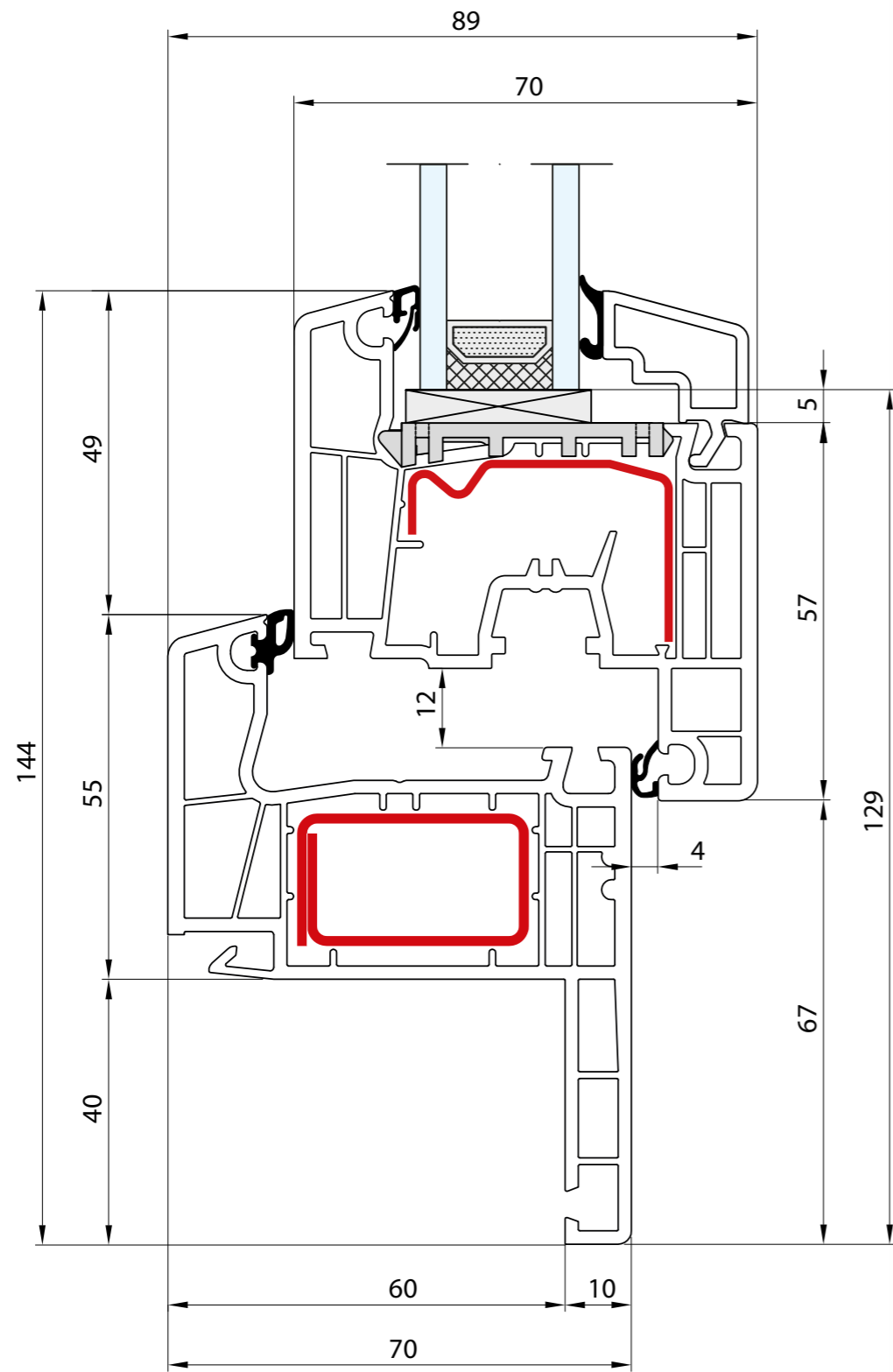
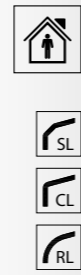

- RENOWACJA - Pletwa: 40 mm · Rama: 55 mm · Skrzydło: 77 mm
- RÉNOVATION - Lip: 40 mm · Dormant: 55 mm · Vantail: 77 mm
- RENOVATION - Strip: 40 mm · Frame: 55 mm · Sash: 77 mm
- RENOVIERUNG - Flosse: 40 mm · Rahmen: 55 mm · Flügel: 77 mm
- RINNOVAZIONE - Aletta da: 40 mm · Telaio: 55 mm · Anta: 77 mm

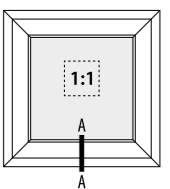
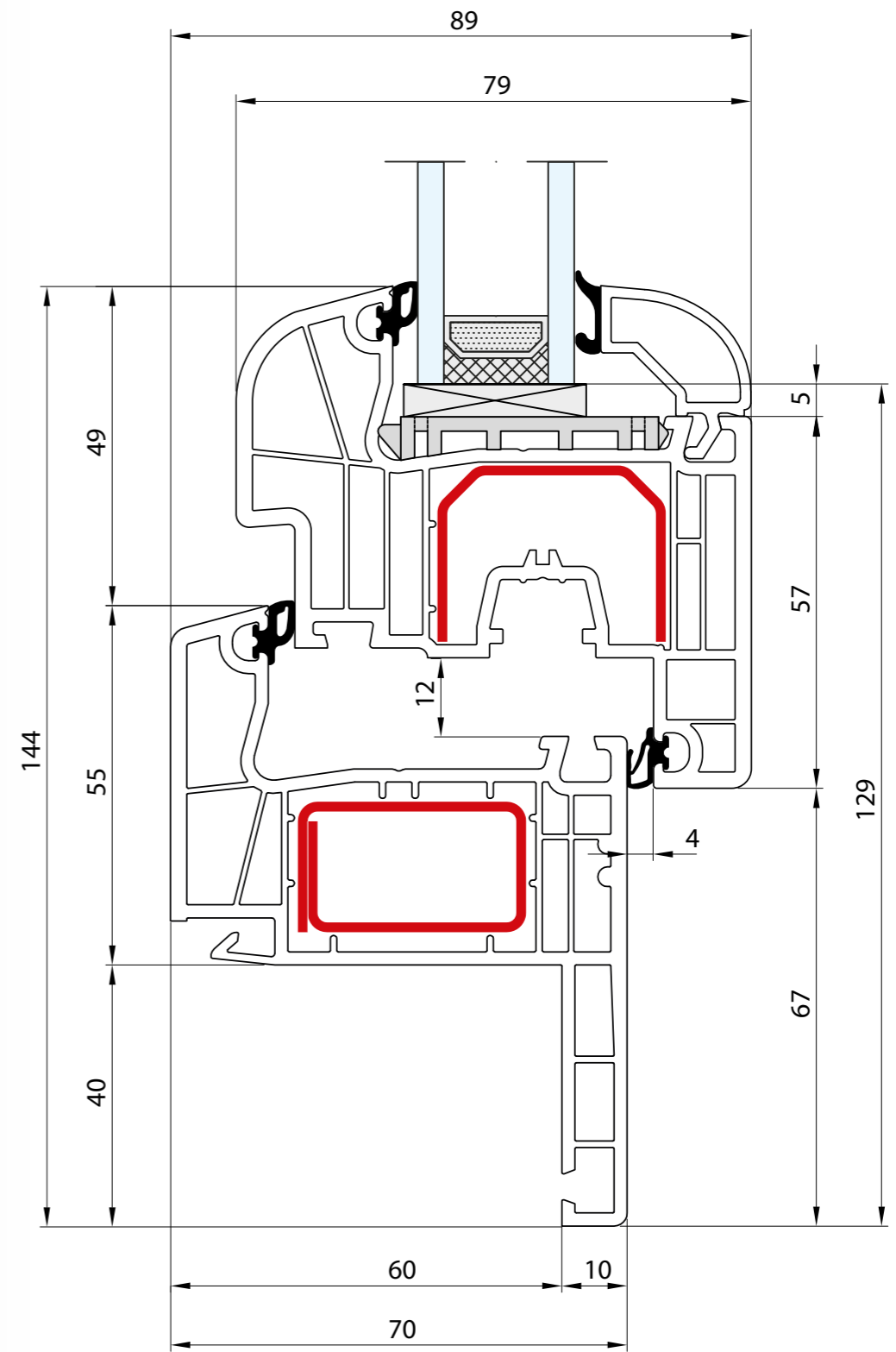

- RENOWACJA - Pletwa: 40 mm · Rama: 55 mm · Skrzydło: 77 mm
- RÉNOVATION - Lip: 40 mm · Dormant: 55 mm · Vantail: 77 mm
- RENOVATION - Strip: 40 mm · Frame: 55 mm · Sash: 77 mm
- RENOVIERUNG - Flosse: 40 mm · Rahmen: 55 mm · Flügel: 77 mm
- RINNOVAZIONE - Aletta da: 40 mm · Telaio: 55 mm · Anta: 77 mm

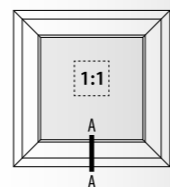
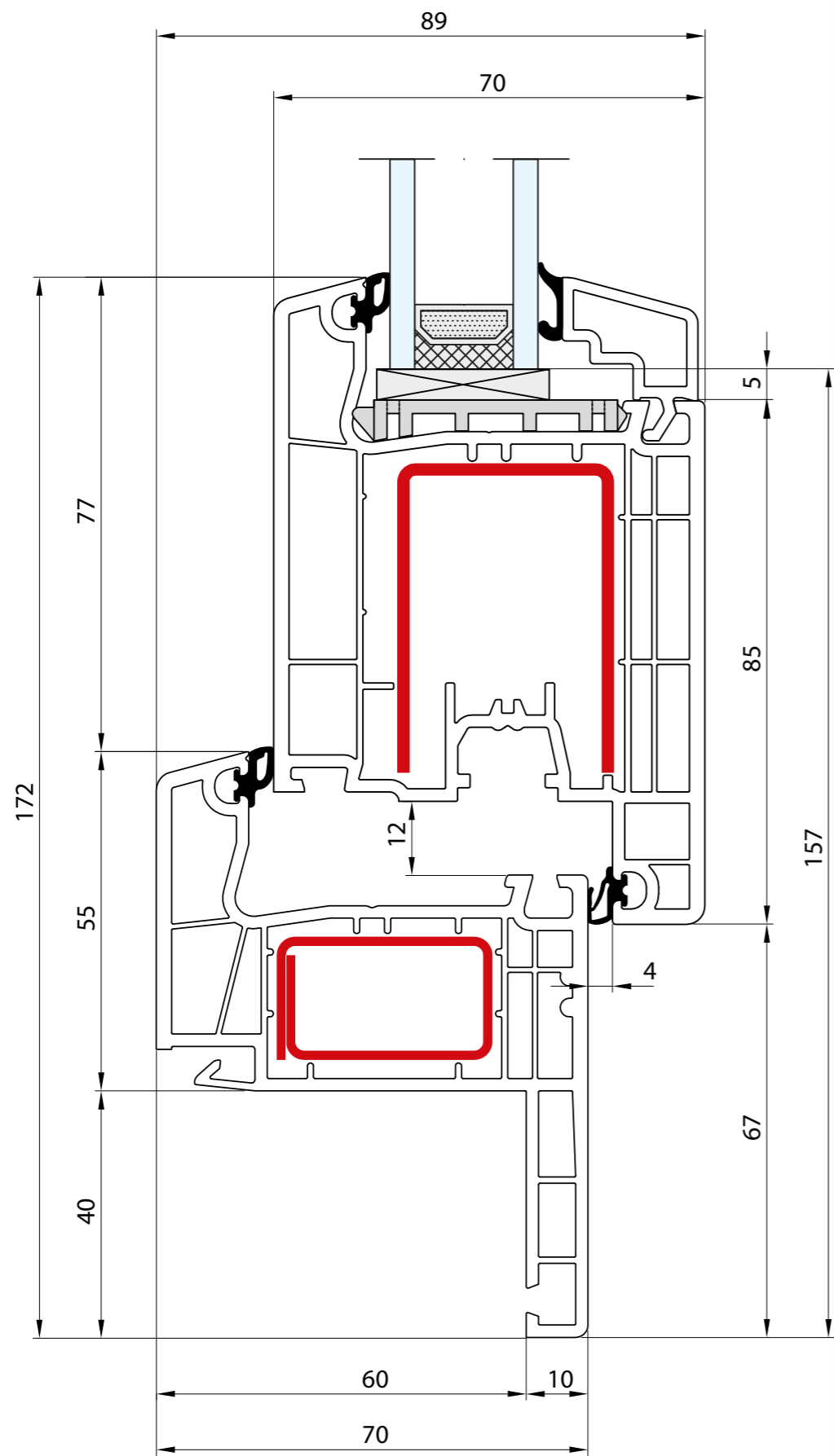

- RENOWACJA - Pletwa: 40 mm · Rama: 55 mm · Skrzydło: 105 mm
- RÉNOVATION - Lip: 40 mm · Dormant: 55 mm · Vantail: 105 mm
- RENOVATION - Strip: 40 mm · Frame: 55 mm · Sash: 105 mm
- RENOVIERUNG - Flosse: 40 mm · Rahmen: 55 mm · Flügel: 105 mm
- RINNOVAZIONE - Aletta da: 40 mm · Telaio: 55 mm · Anta: 105 mm

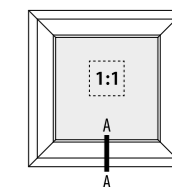
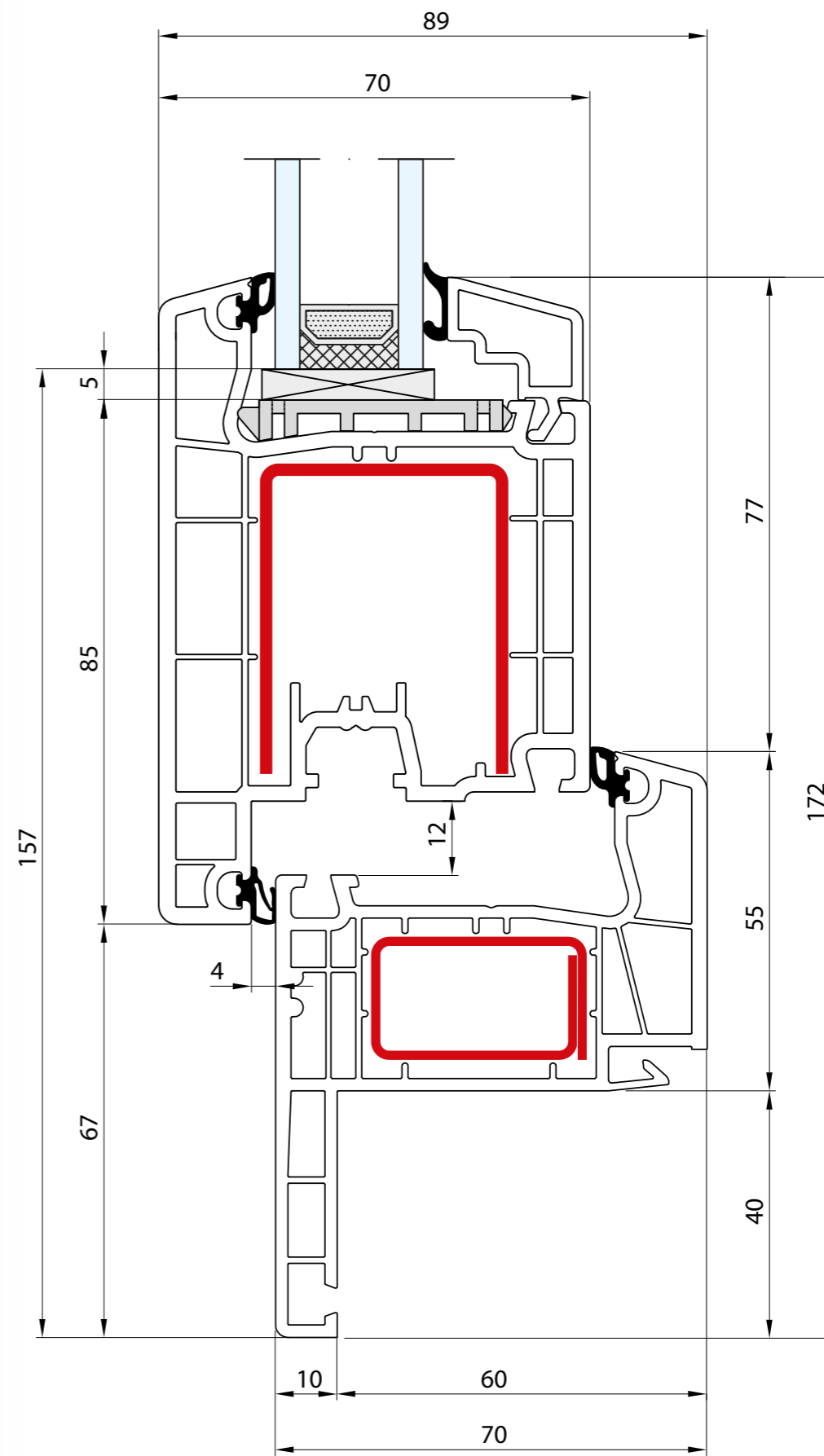

- RENOWACJA - Pletwa: 40 mm · Rama: 55 mm · Skrzydło: 105 mm
- RÉNOVATION - Lip: 40 mm · Dormant: 55 mm · Vantail: 105 mm
- RENOVATION - Strip: 40 mm · Frame: 55 mm · Sash: 105 mm
- RENOVIERUNG - Flosse: 40 mm · Rahmen: 55 mm · Flügel: 105 mm
- RINNOVAZIONE - Aletta da: 40 mm · Telaio: 55 mm · Anta: 105 mm

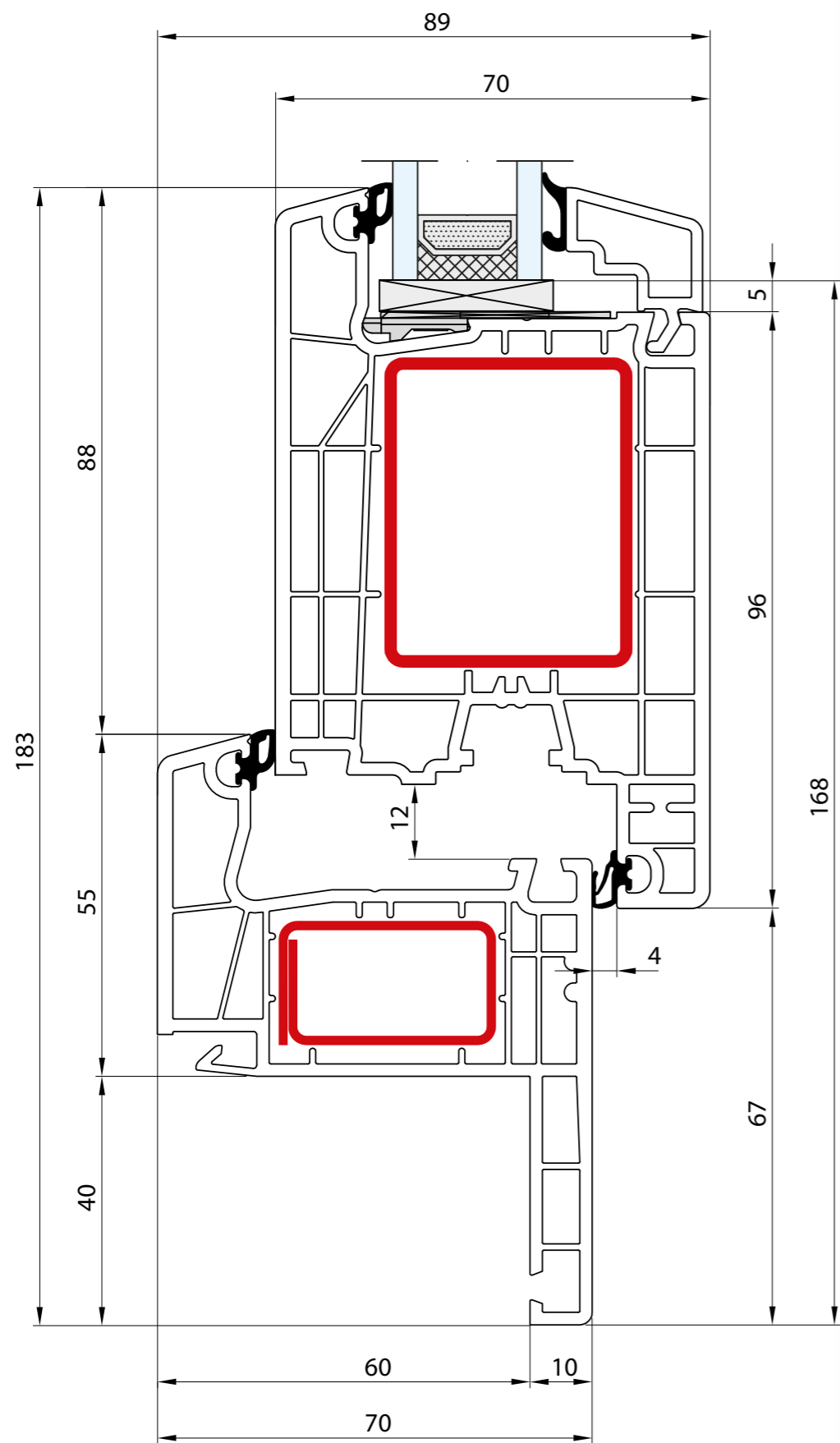

- RENOWACJA - Pletwa: 40 mm · Rama: 55 mm · Skrzydło: 116 mm
- RÉNOVATION - Lip: 40 mm · Dormant: 55 mm · Vantail: 116 mm
- RENOVATION - Strip: 40 mm · Frame: 55 mm · Sash: 116 mm
- RENOVIERUNG - Flosse: 40 mm · Rahmen: 55 mm · Flügel: 116 mm
- RINNOVAZIONE - Aletta da: 40 mm · Telaio: 55 mm · Anta: 116 mm

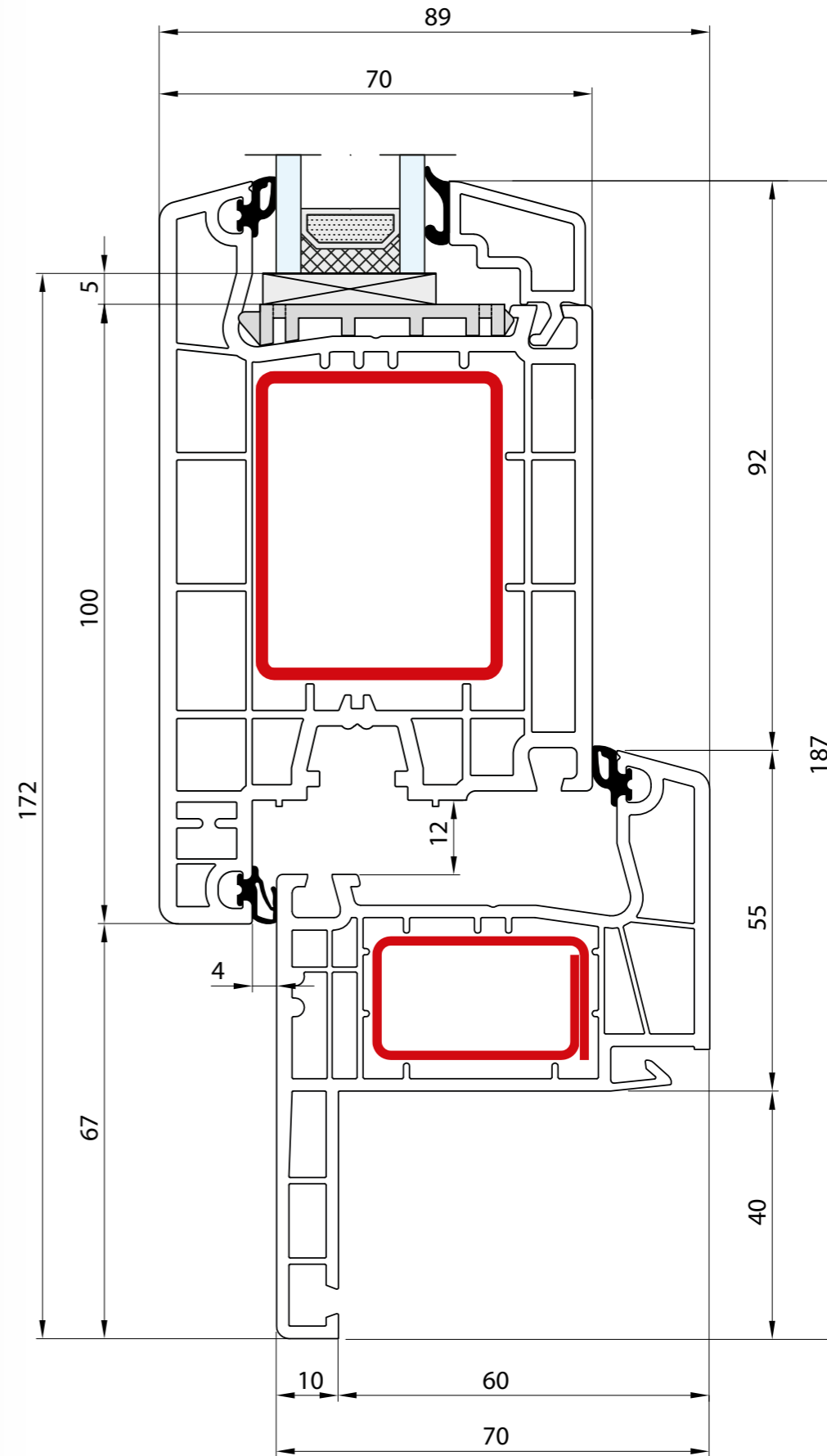
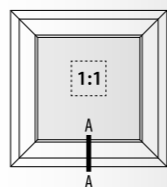

- RENOWACJA - Pletwa: 40 mm · Rama: 55 mm · Skrzydło: 120 mm
- RÉNOVATION - Lip: 40 mm · Dormant: 55 mm · Vantail: 120 mm
- RENOVATION - Strip: 40 mm · Frame: 55 mm · Sash: 120 mm
- RENOVIERUNG - Flosse: 40 mm · Rahmen: 55 mm · Flügel: 120 mm
- RINNOVAZIONE - Aletta da: 40 mm · Telaio: 55 mm · Anta: 120 mm

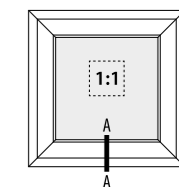

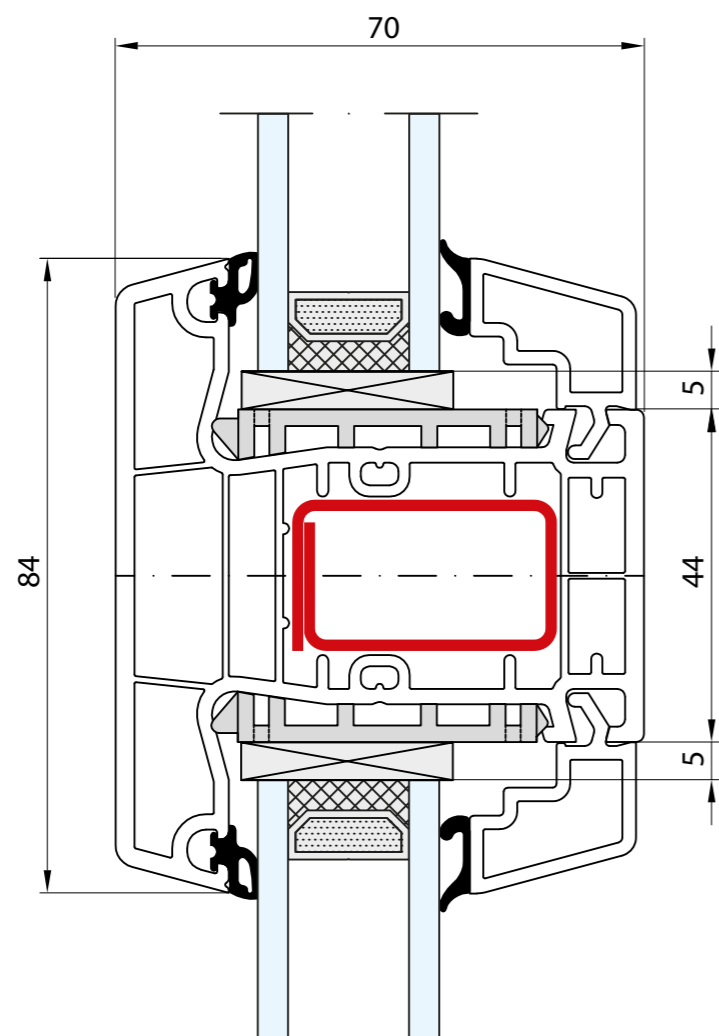



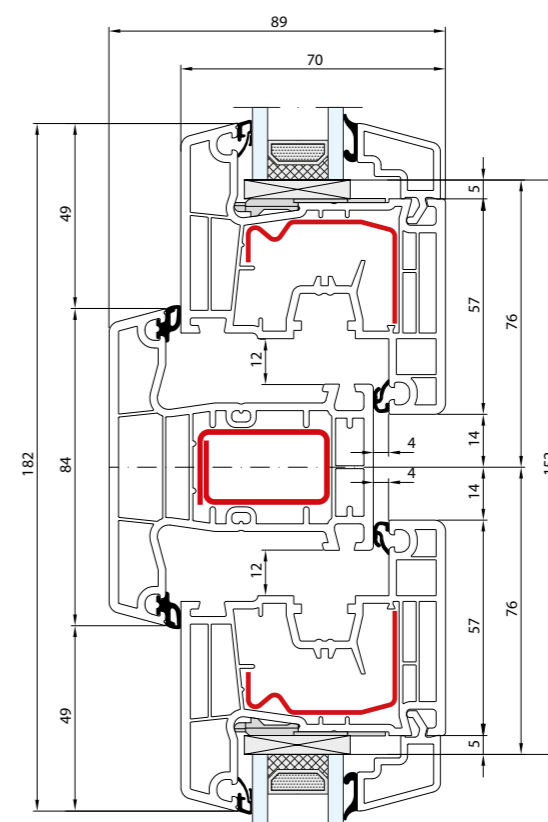
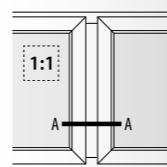

- Słupek stały: 84 mm
- Meneau fixe: 84 mm
- Fix post: 84 mm
- Festem Pfahl: 84 mm
- Montante fisso: 84 mm

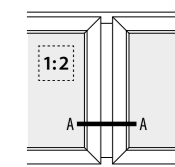

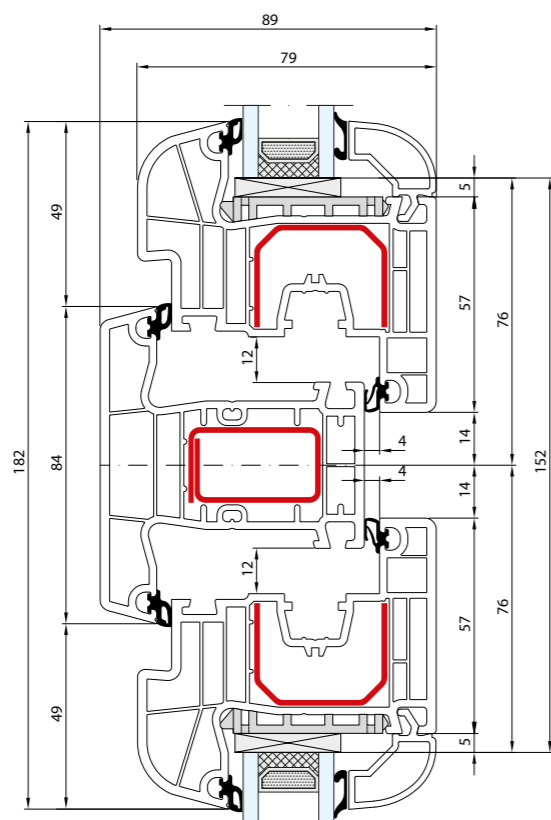





- Słupek stały: 84 mm · Skrzydło: 77 mm
- Meneau fixe: 84 mm · Vantail: 77 mm
- Fix post: 84 mm · Sash: 77 mm
- Festem Pfahl: 84 mm · Flügel: 77 mm
- Montante fisso: 84 mm · Anta: 77 mm

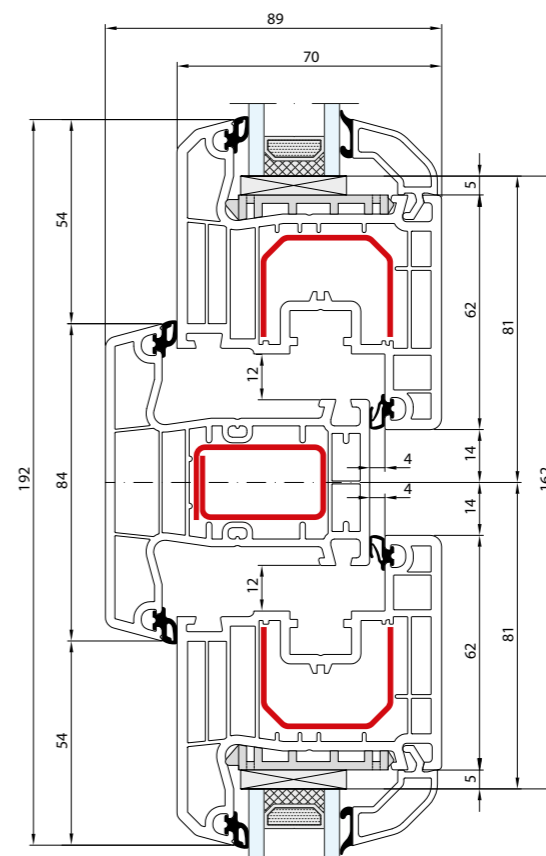
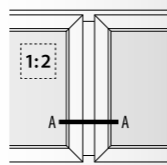







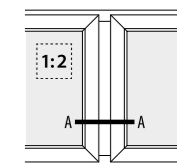

-  Słupek stały: 84 mm · Skrzydło: 77 mm
-  Meneau fixe: 84 mm · Vantail: 77 mm
-  Fix post: 84 mm · Sash: 77 mm
-  Festem Pfahl: 84 mm · Flügel: 77 mm
-  Montante fisso: 84 mm · Anta: 77 mm

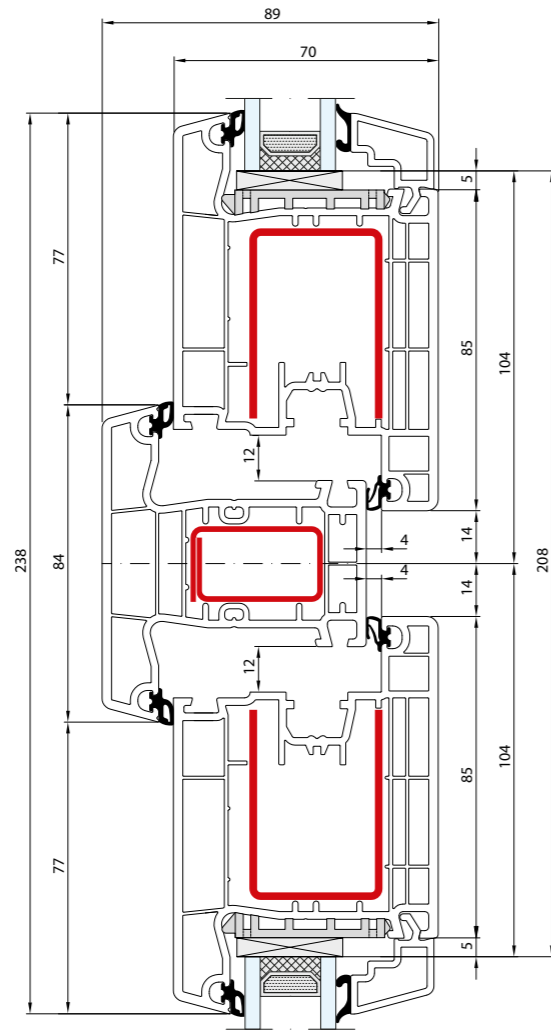







-  Słupek stały: 84 mm · Skrzydło: 82 mm
-  Meneau fixe: 84 mm · Vantail: 82 mm
-  Fix post: 84 mm · Sash: 82 mm
-  Festem Pfahl: 84 mm · Flügel: 82 mm
-  Montante fisso: 84 mm · Anta: 82 mm

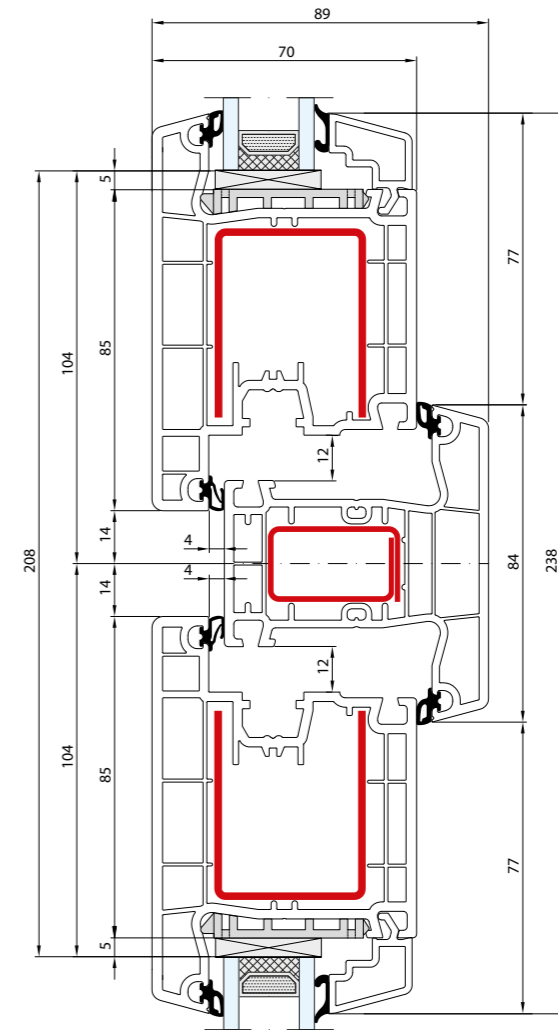
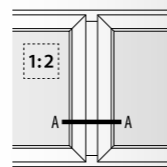







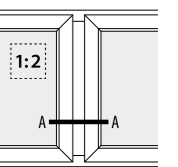

-  Słupek stały: 84 mm · Skrzydło: 105 mm
-  Meneau fixe: 84 mm · Vantail: 105 mm
-  Fix post: 84 mm · Sash: 105 mm
-  Festem Pfahl: 84 mm · Flügel: 105 mm
-  Montante fisso: 84 mm · Anta: 105 mm

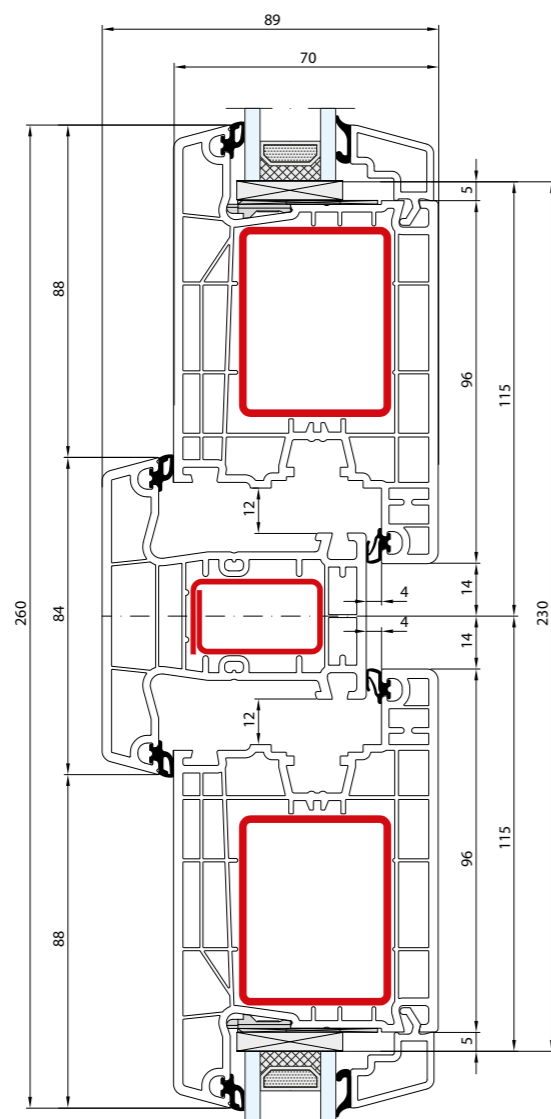



-  Słupek stały: 84 mm · Skrzydło: 105 mm
-  Meneau fixe: 84 mm · Vantail: 105 mm
-  Fix post: 84 mm · Sash: 105 mm
-  Festem Pfahl: 84 mm · Flügel: 105 mm
-  Montante fisso: 84 mm · Anta: 105 mm



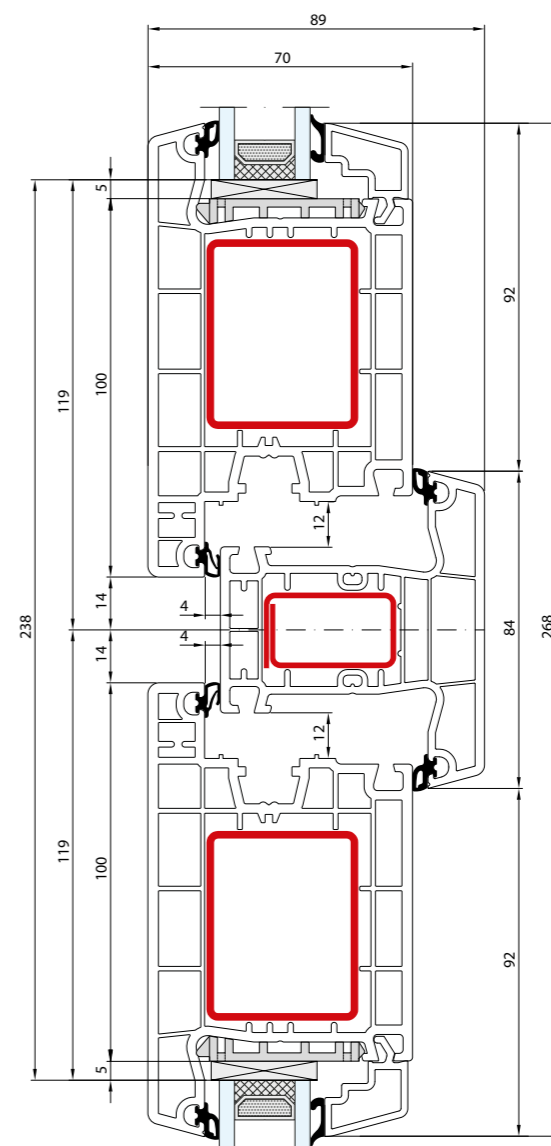
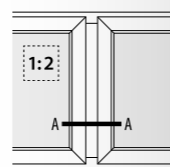

-  Słupek stały: 84 mm · Skrzydło: 116 mm
-  Meneau fixe: 84 mm · Vantail: 116 mm
-  Fix post: 84 mm · Sash: 116 mm
-  Festem Pfahl: 84 mm · Flügel: 116 mm
-  Montante fisso: 84 mm · Anta: 116 mm



-  Słupek stały: 84 mm · Skrzydło: 120 mm
-  Meneau fixe: 84 mm · Vantail: 120 mm
-  Fix post: 84 mm · Sash: 120 mm
-  Festem Pfahl: 84 mm · Flügel: 120 mm
-  Montante fisso: 84 mm · Anta: 120 mm

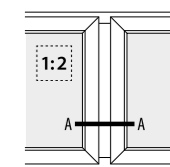

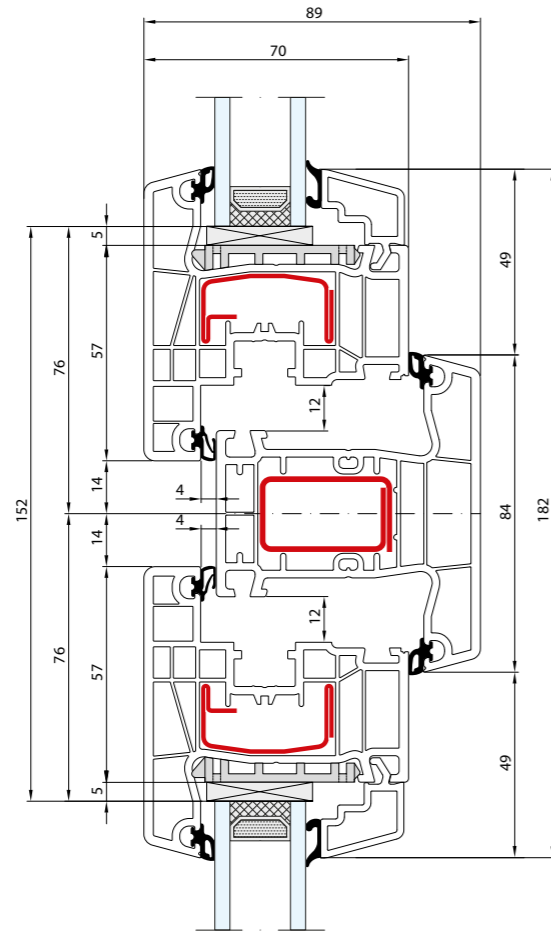

- Słupek stały: 84 mm · Skrzydło: 77 mm
- Meneau fixe: 84 mm · Vantail: 77 mm
- Fix post: 84 mm · Sash: 77 mm
- Festem Pfahl: 84 mm · Flügel: 77 mm
- Montante fisso: 84 mm · Anta: 77 mm

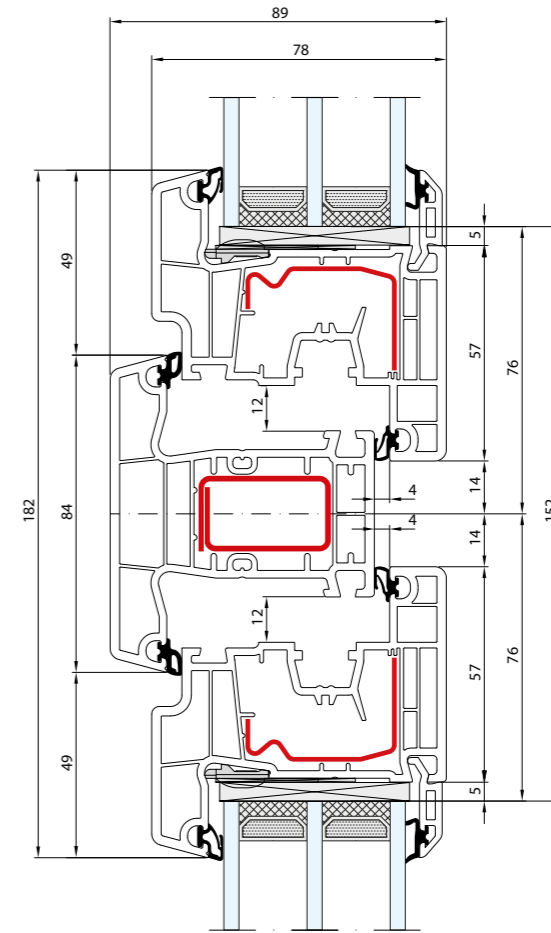
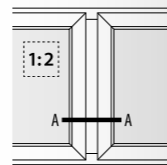

- Słupek stały: 84 mm · Skrzydło: 77 mm
- Meneau fixe: 84 mm · Vantail: 77 mm
- Fix post: 84 mm · Sash: 77 mm
- Festem Pfahl: 84 mm · Flügel: 77 mm
- Montante fisso: 84 mm · Anta: 77 mm

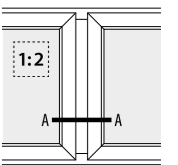

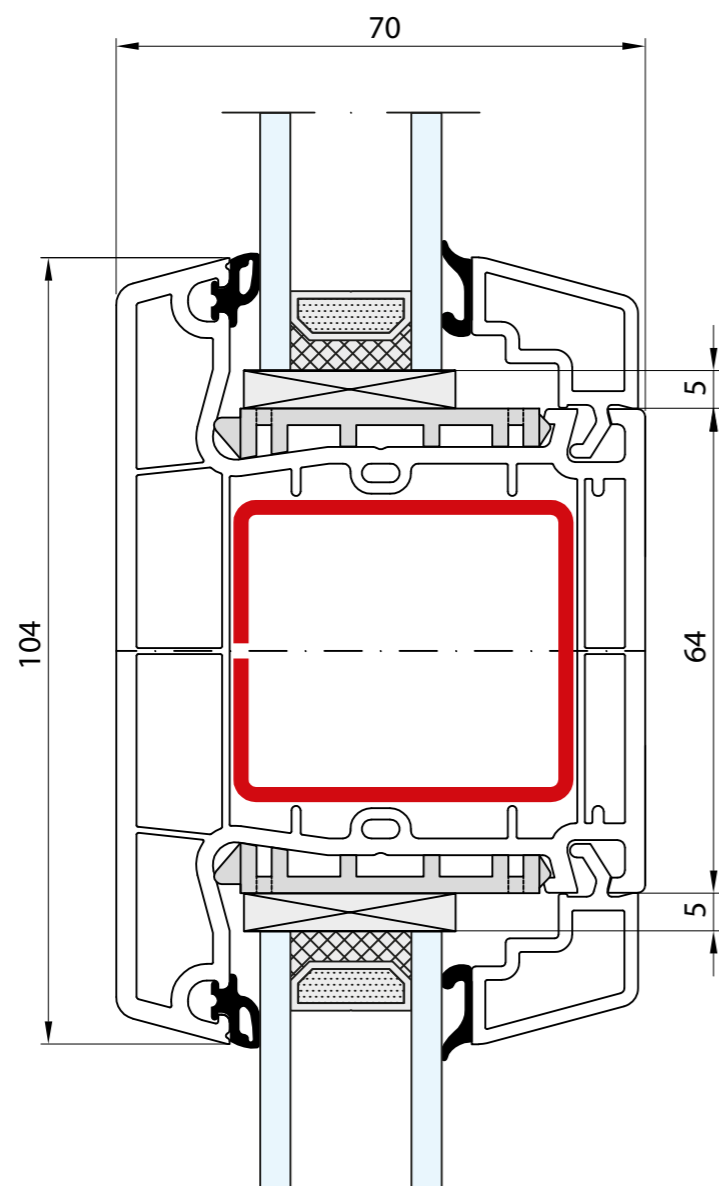

- Słupek stały: 104 mm
- Meneau fixe: 104 mm
- Fix post: 104 mm
- Festem Pfahl: 104 mm
- Montante fisso: 104 mm

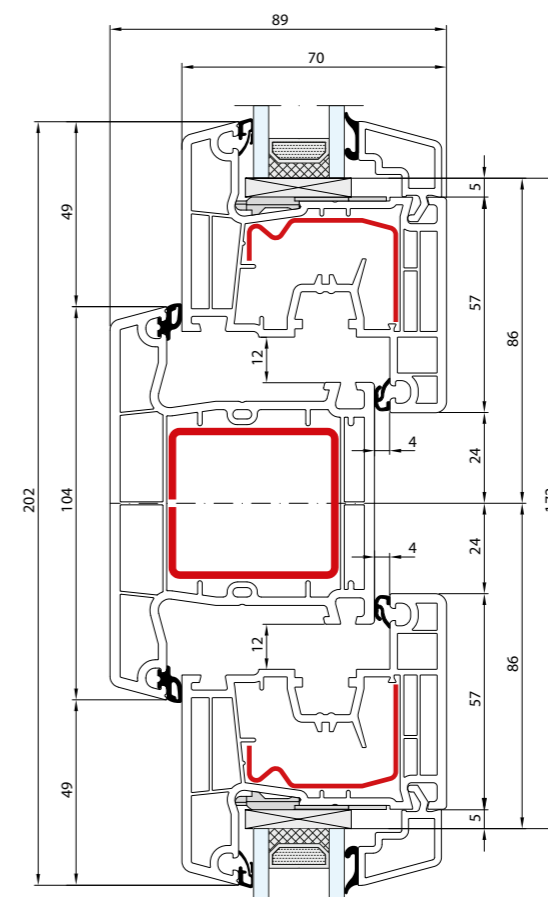
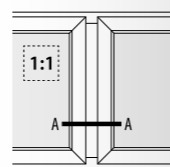

- Słupek stały: 104 mm · Skrzydło: 77 mm
- Meneau fixe: 104 mm · Vantail: 77 mm
- Fix post: 104 mm · Sash: 77 mm
- Festem Pfahl: 104 mm · Flügel: 77 mm
- Montante fisso: 104 mm · Anta: 77 mm

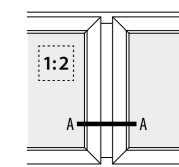

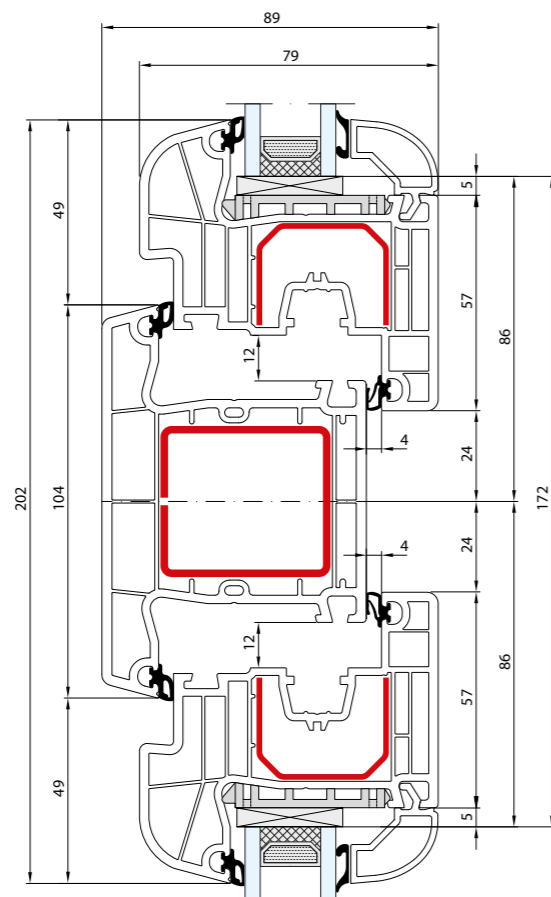

- Słupek stały: 104 mm · Skrzydło: 77 mm
- Meneau fixe: 104 mm · Vantail: 77 mm
- Fix post: 104 mm · Sash: 77 mm
- Festem Pfahl: 104 mm · Flügel: 77 mm
- Montante fisso: 104 mm · Anta: 77 mm

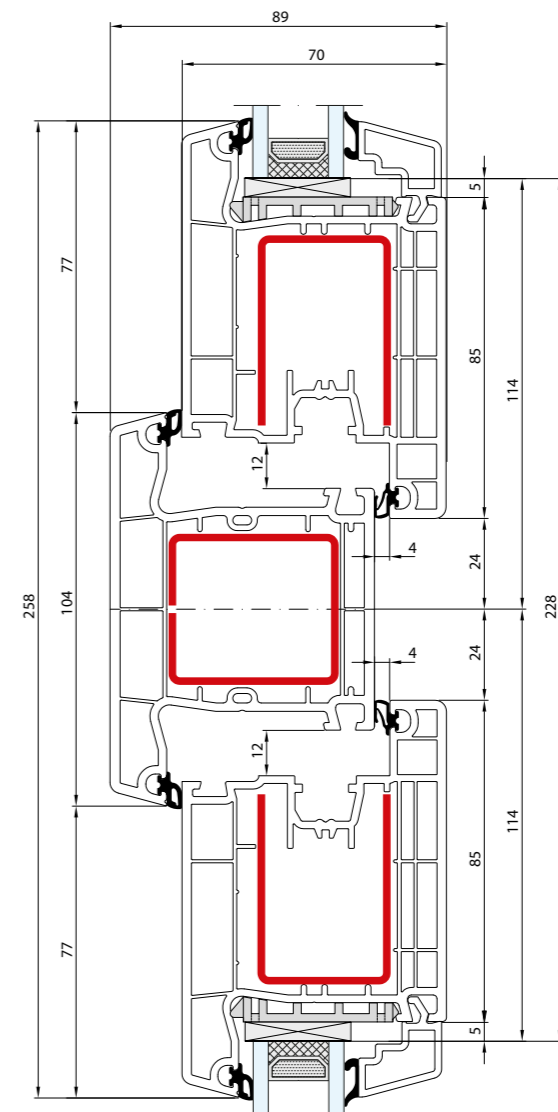
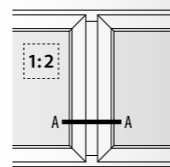

- Słupek stały: 104 mm · Skrzydło: 105 mm
- Meneau fixe: 104 mm · Vantail: 105 mm
- Fix post: 104 mm · Sash: 105 mm
- Festem Pfahl: 104 mm · Flügel: 105 mm
- Montante fisso: 104 mm · Anta: 105 mm

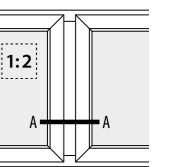

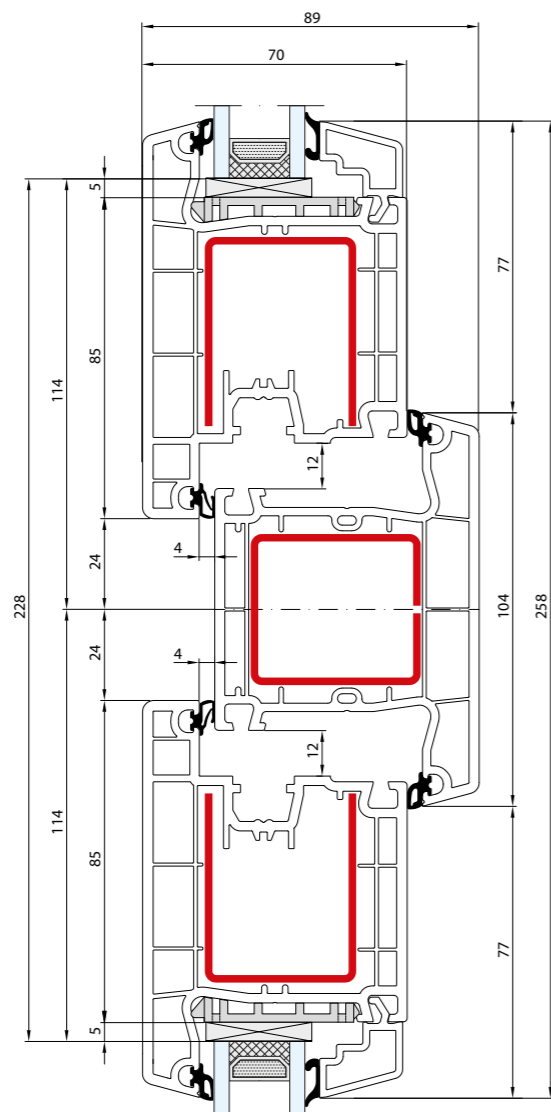

- Słupek stały: 104 mm · Skrzydło: 105 mm
- Meneau fixe: 104 mm · Vantail: 105 mm
- Fix post: 104 mm · Sash: 105 mm
- Festem Pfahl: 104 mm · Flügel: 105 mm
- Montante fisso: 104 mm · Anta: 105 mm

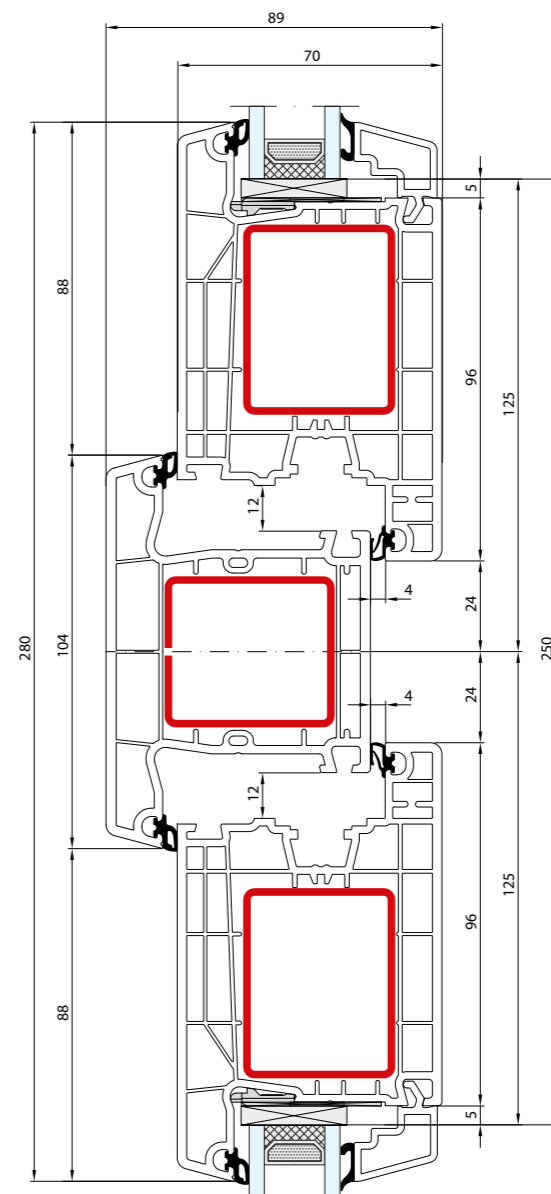
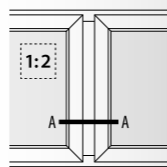

- Słupek stały: 104 mm · Skrzydło: 116 mm
- Meneau fixe: 104 mm · Vantail: 116 mm
- Fix post: 104 mm · Sash: 116 mm
- Festem Pfahl: 104 mm · Flügel: 116 mm
- Montante fisso: 104 mm · Anta: 116 mm

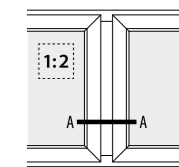

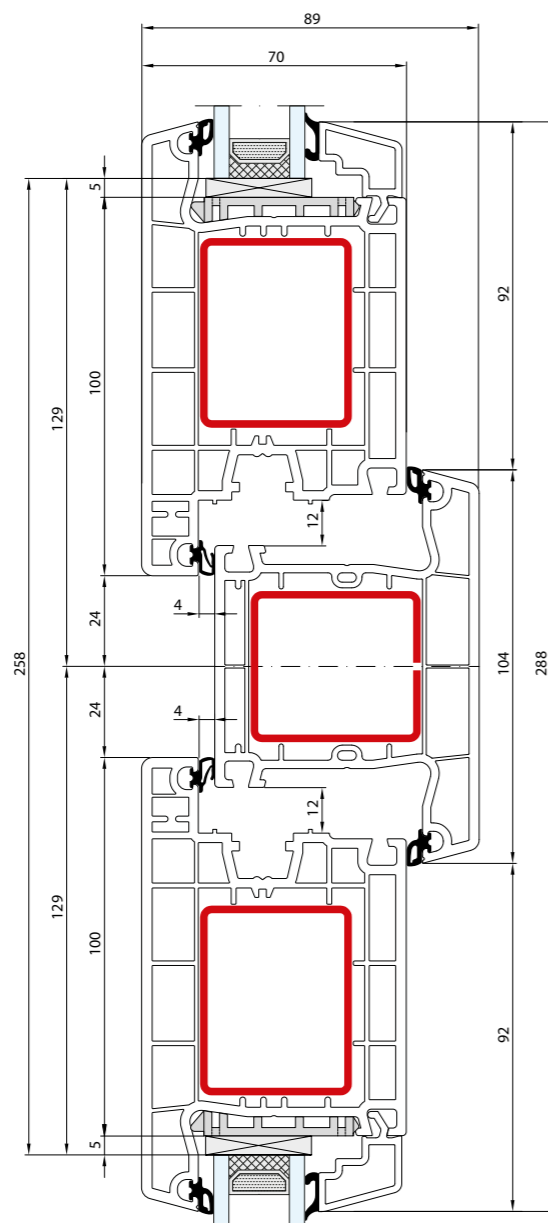

- Słupek stały: 104 mm · Skrzydło: 120 mm
- Meneau fixe: 104 mm · Vantail: 120 mm
- Fix post: 104 mm · Sash: 120 mm
- Festem Pfahl: 104 mm · Flügel: 120 mm
- Montante fisso: 104 mm · Anta: 120 mm

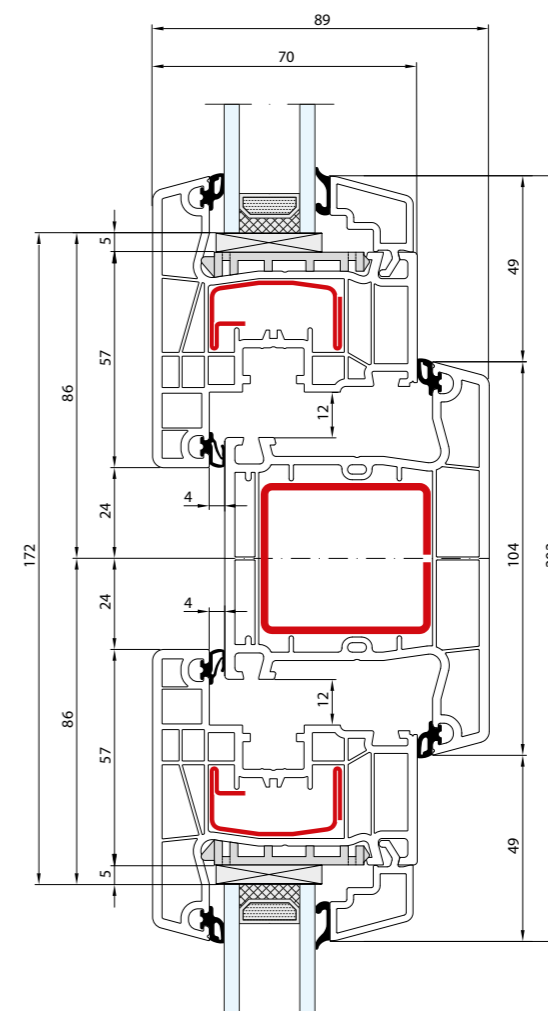
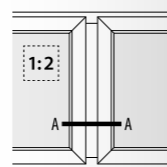



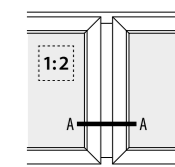

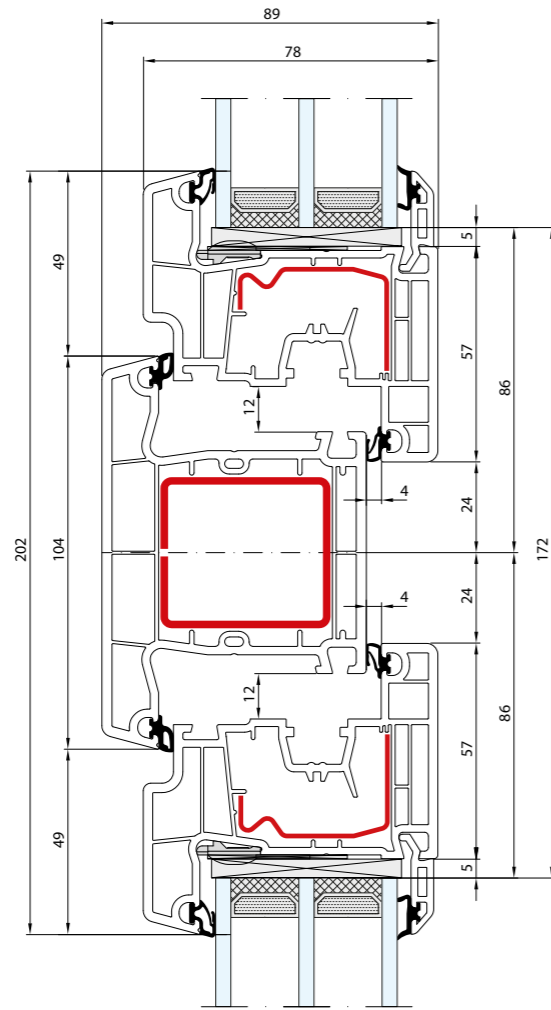

- Słupek stały: 104 mm · Skrzydło: 77 mm
- Meneau fixe: 104 mm · Vantail: 77 mm
- Fix post: 104 mm · Sash: 77 mm
- Festem Pfahl: 104 mm · Flügel: 77 mm
- Montante fisso: 104 mm · Anta: 77 mm

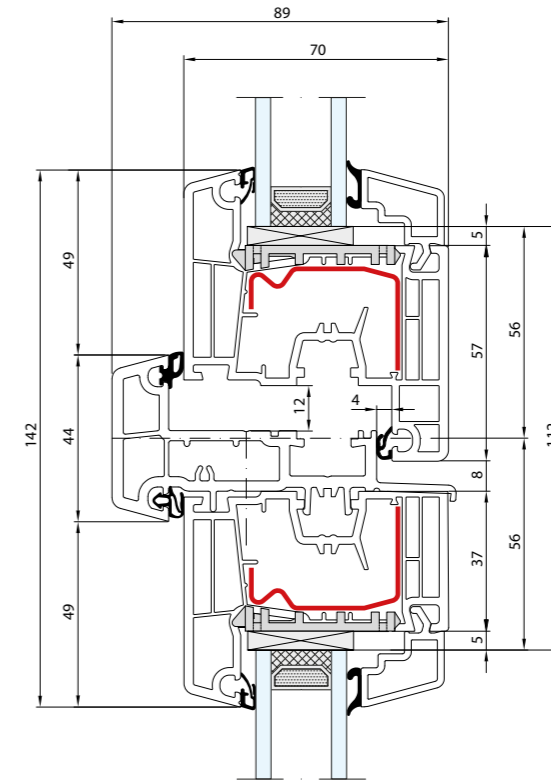
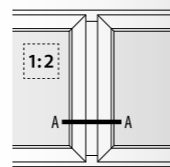



-  Słupek stały: 104 mm · Skrzydło: 77 mm
-  Meneau fixe: 104 mm · Vantail: 77 mm
-  Fix post: 104 mm · Sash: 77 mm
-  Festem Pfahl: 104 mm · Flügel: 77 mm
-  Montante fisso: 104 mm · Anta: 77 mm



-  Słupek ruchomy: 44 mm · Skrzydło: 77 mm / 57 mm
-  Meneau mobile: 44 mm · Vantail: 77 mm / 57 mm
-  Movable post: 44 mm · Sash: 77 mm / 57 mm
-  Stulp: 44 mm · Flügel: 77 mm / 57 mm
-  Montante mobile: 44 mm · Anta: 77 mm / 57 mm

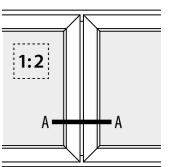

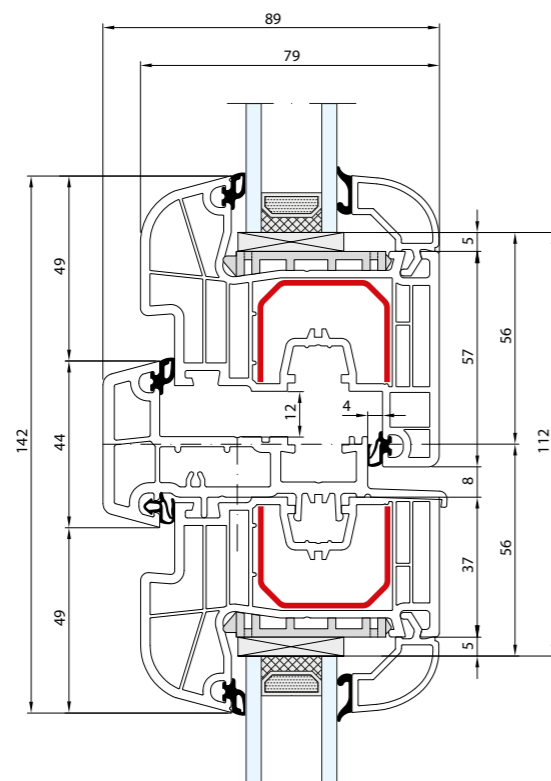



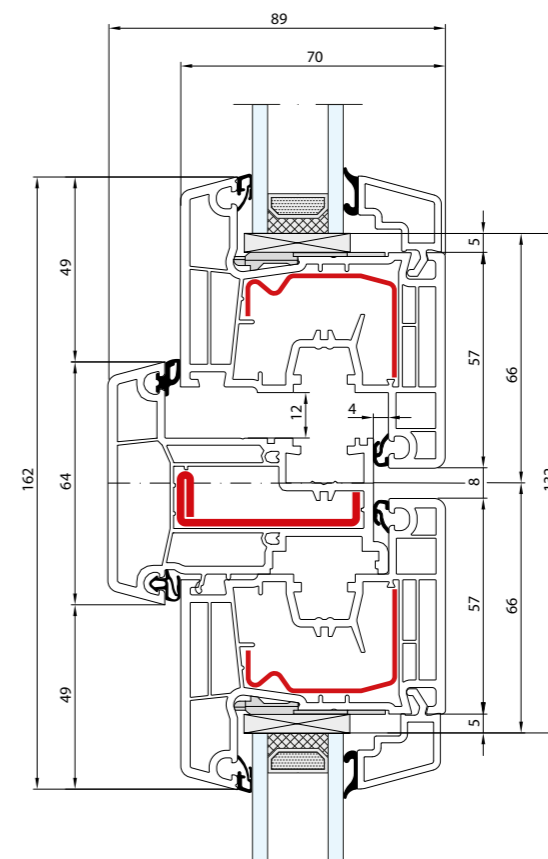
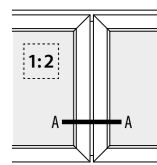
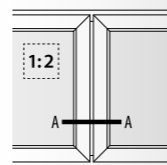

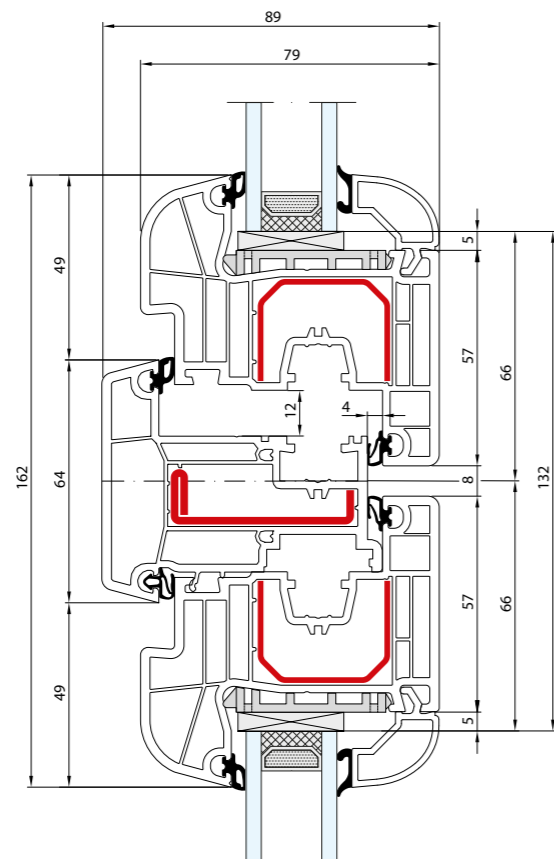

- Słupek ruchomy: 44 mm · Skrzydło: 77 mm / 57 mm
- Meneau mobile: 44 mm · Vantail: 77 mm / 57 mm
- Movable post: 44 mm · Sash: 77 mm / 57 mm
- Stulp: 44 mm · Flügel: 77 mm / 57 mm
- Montante mobile: 44 mm · Anta: 77 mm / 57 mm







- Słupek ruchomy: 64 mm · Skrzydło: 77 mm
- Meneau mobile: 64 mm · Vantail: 77 mm
- Movable post: 64 mm · Sash: 77 mm
- Stulp: 64 mm · Flügel: 77 mm
- Montante mobile: 64 mm · Anta: 77 mm

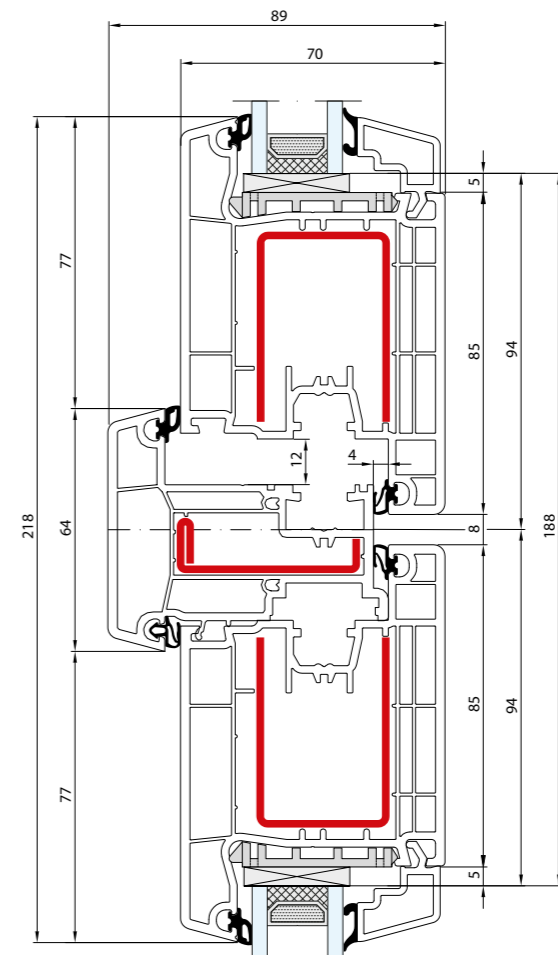
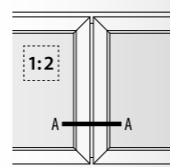

-  Słupek ruchomy: 64 mm · Skrzydło: 77 mm
-  Meneau mobile: 64 mm · Vantail: 77 mm
-  Movable post: 64 mm · Sash: 77 mm
-  Stulp: 64 mm · Flügel: 77 mm
-  Montante mobile: 64 mm · Anta: 77 mm



-  Słupek ruchomy: 64 mm · Skrzydło: 105 mm
-  Meneau mobile: 64 mm · Vantail: 105 mm
-  Movable post: 64 mm · Sash: 105 mm
-  Stulp: 64 mm · Flügel: 105 mm
-  Montante mobile: 64 mm · Anta: 105 mm

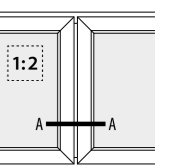

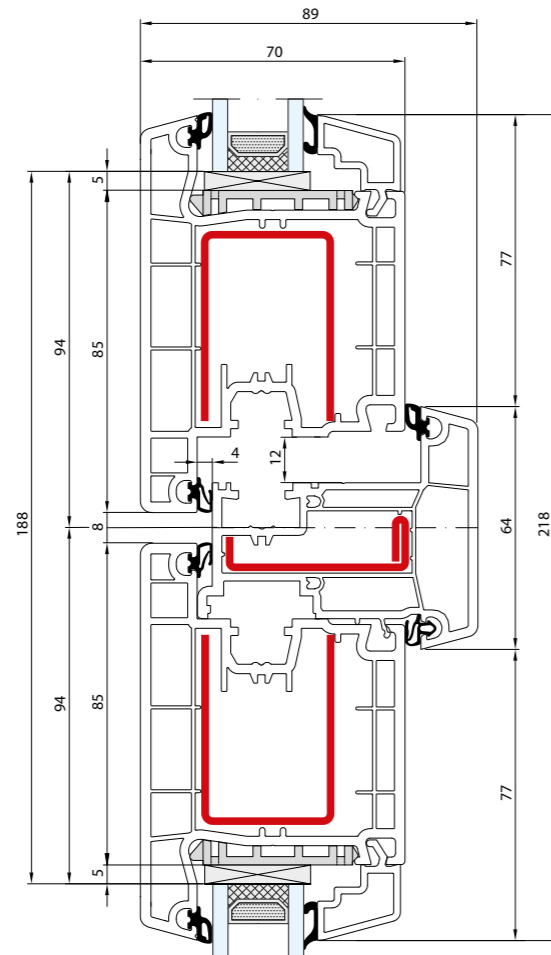

- Słupek ruchomy: 64 mm · Skrzydło: 105 mm
- Meneau mobile: 64 mm · Vantail: 105 mm
- Movable post: 64 mm · Sash: 105 mm
- Stulp: 64 mm · Flügel: 105 mm
- Montante mobile: 64 mm · Anta: 105 mm

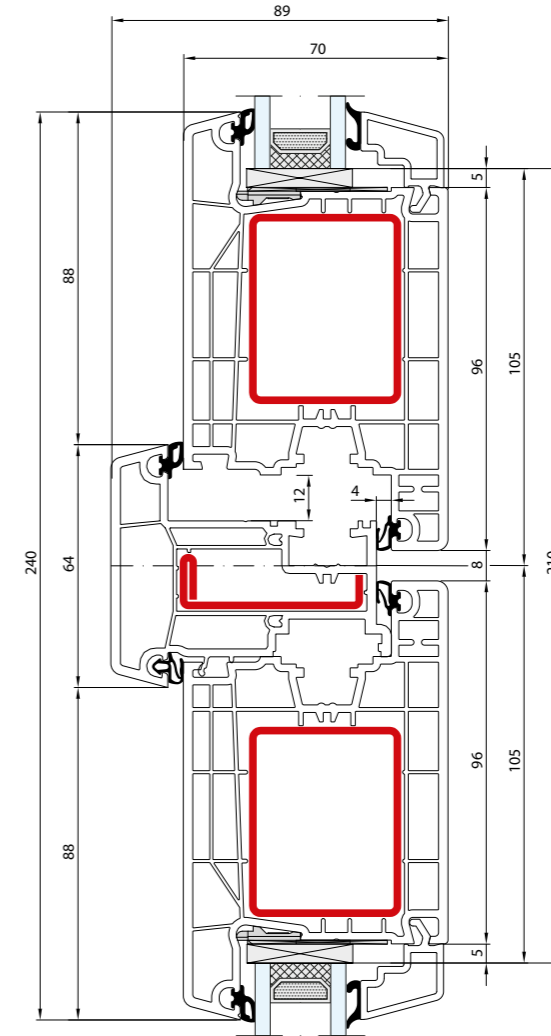
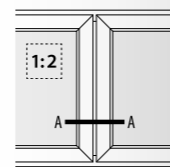

- Słupek ruchomy: 64 mm · Skrzydło: 116 mm
- Meneau mobile: 64 mm · Vantail: 116 mm
- Movable post: 64 mm · Sash: 116 mm
- Stulp: 64 mm · Flügel: 116 mm
- Montante mobile: 64 mm · Anta: 116 mm

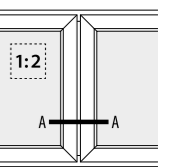

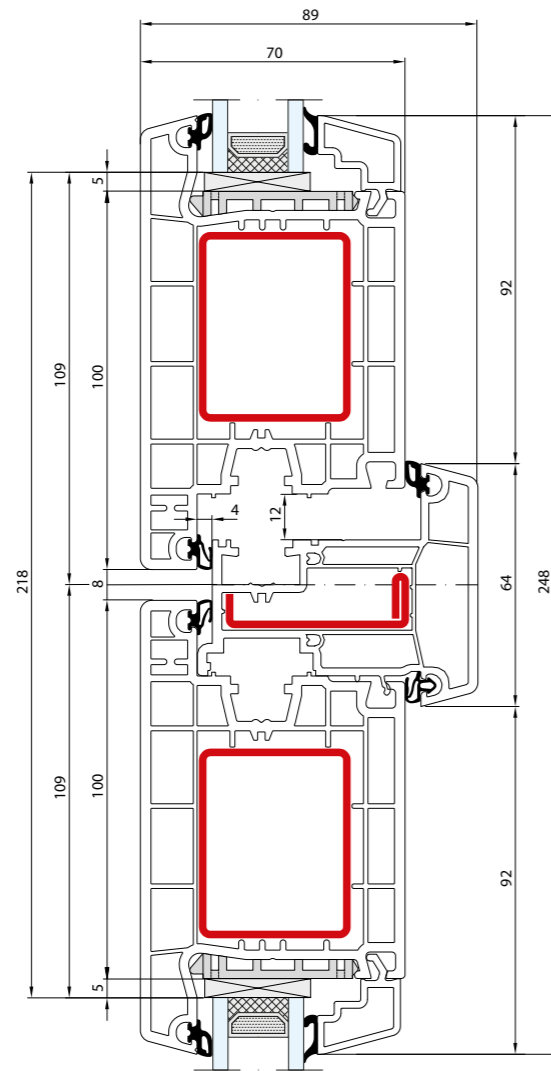

- Słupek ruchomy: 64 mm · Skrzydło: 120 mm
- Meneau mobile: 64 mm · Vantail: 120 mm
- Movable post: 64 mm · Sash: 120 mm
- Stulp: 64 mm · Flügel: 120 mm
- Montante mobile: 64 mm · Anta: 120 mm

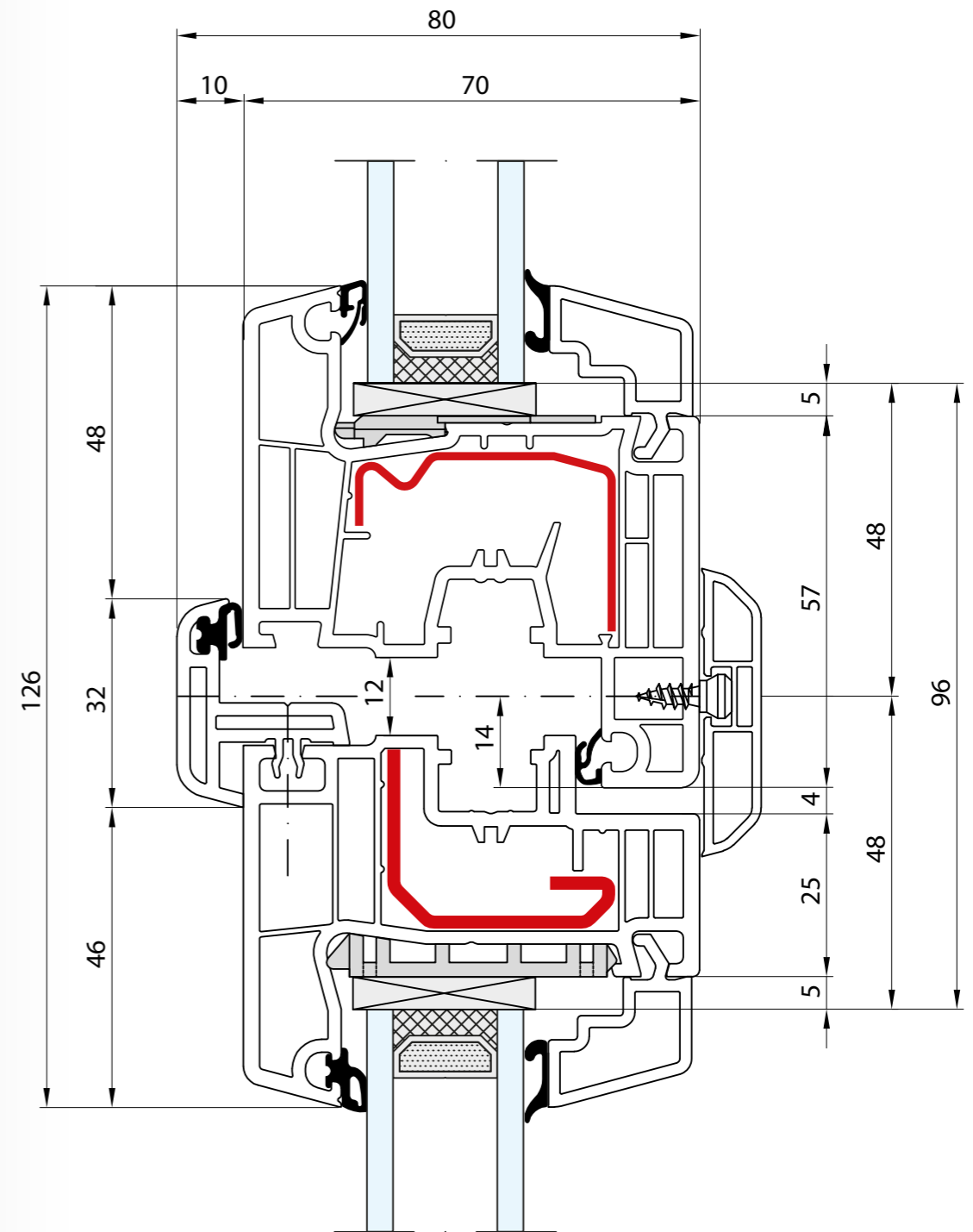
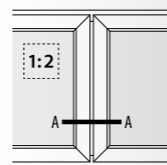

- Klamka centralna · Skrzydło: 77 mm
- Battue centrée · Vantail: 77 mm
- Central handle · Sash: 77 mm
- Zentrale Olive · Flügel: 77 mm
- Maniglia centrale · Anta: 77 mm

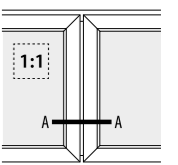

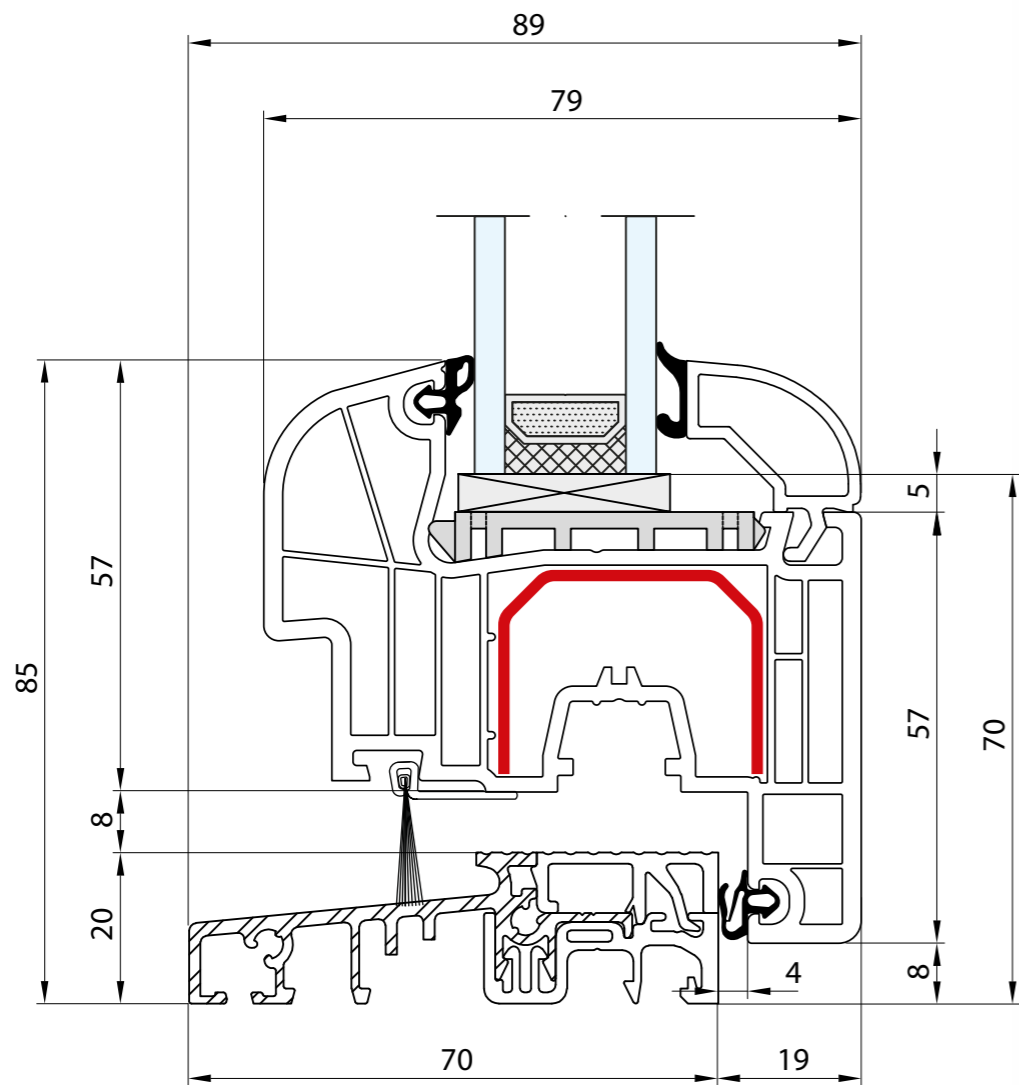

- Próg: 20 mm · Skrzydło: 77 mm
- Seuil: 20 mm · Vantail: 77 mm
- Threshold: 20 mm · Sash: 77 mm
- Schwelle: 20 mm · Flügel: 77 mm
- Soglia: 20 mm · Anta: 77 mm

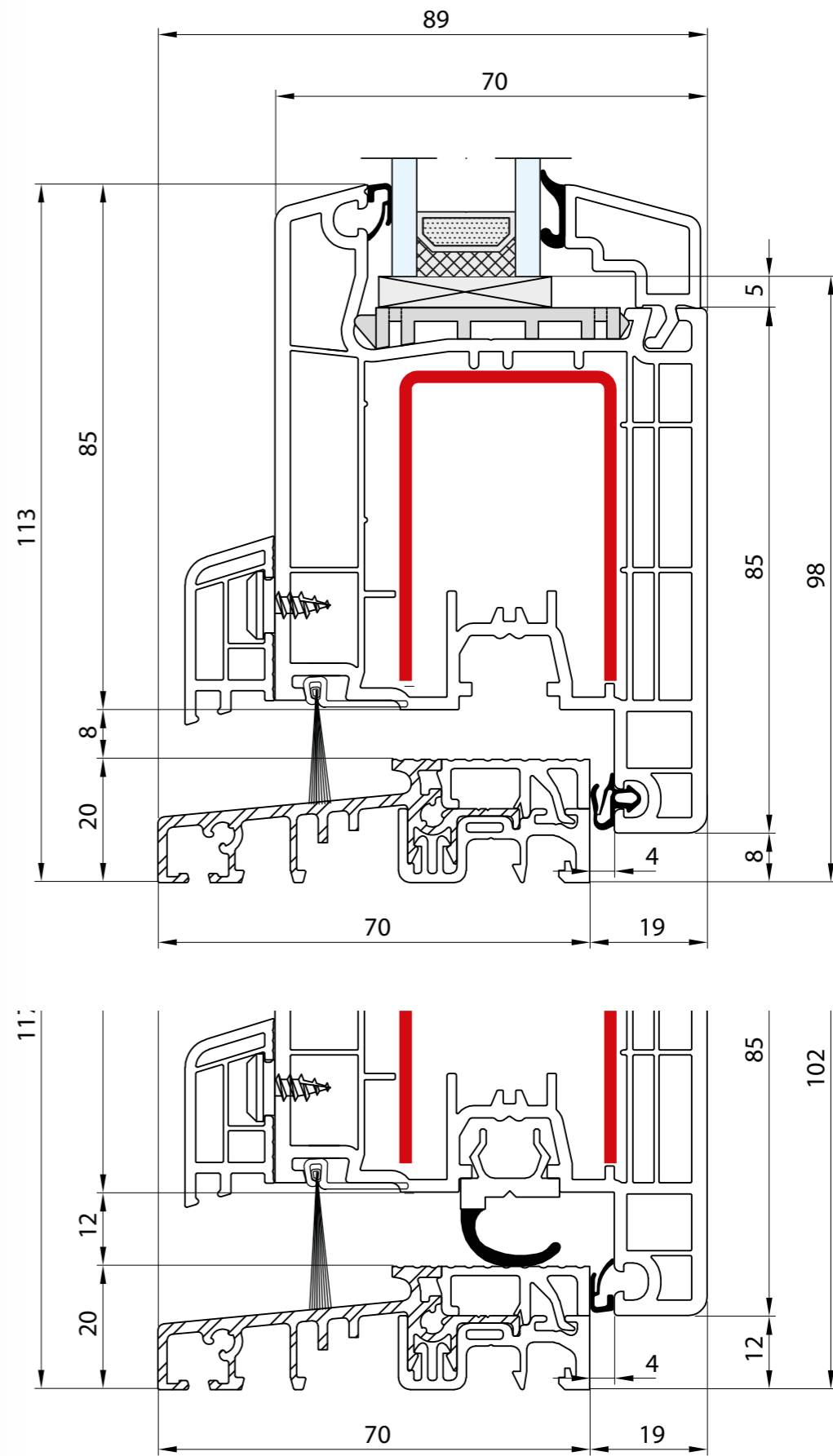
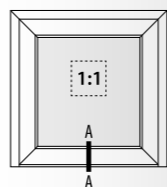

- Próg: 20 mm · Skrzydło: 105 mm
- Seuil: 20 mm · Vantail: 105 mm
- Threshold: 20 mm · Sash: 105 mm
- Schwelle: 20 mm · Flügel: 105 mm
- Soglia: 20 mm · Anta: 105 mm

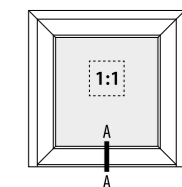

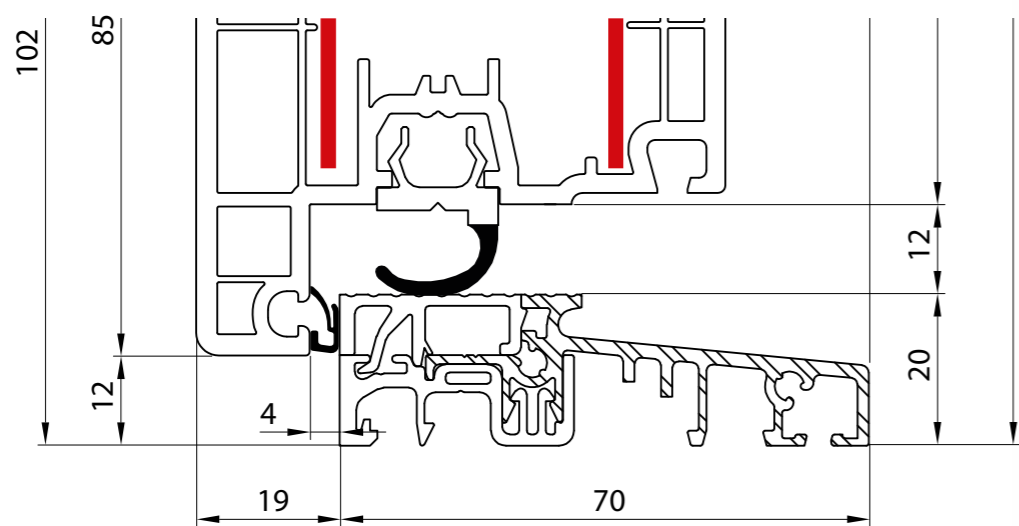
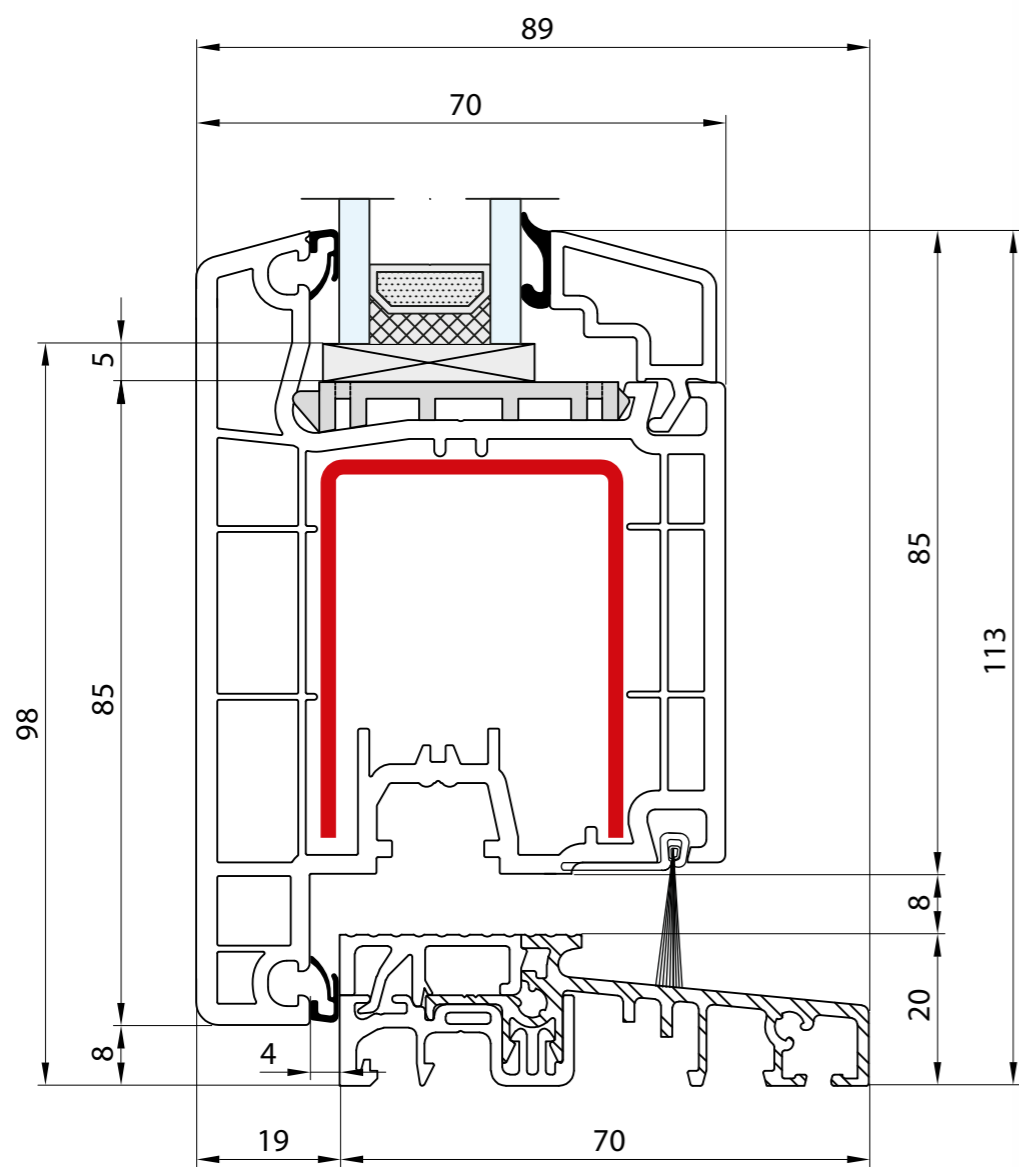

- Próg: 20 mm · Skrzydło: 105 mm
- Seuil: 20 mm · Vantail: 105 mm
- Threshold: 20 mm · Sash: 105 mm
- Schwelle: 20 mm · Flügel: 105 mm
- Soglia: 20 mm · Anta: 105 mm

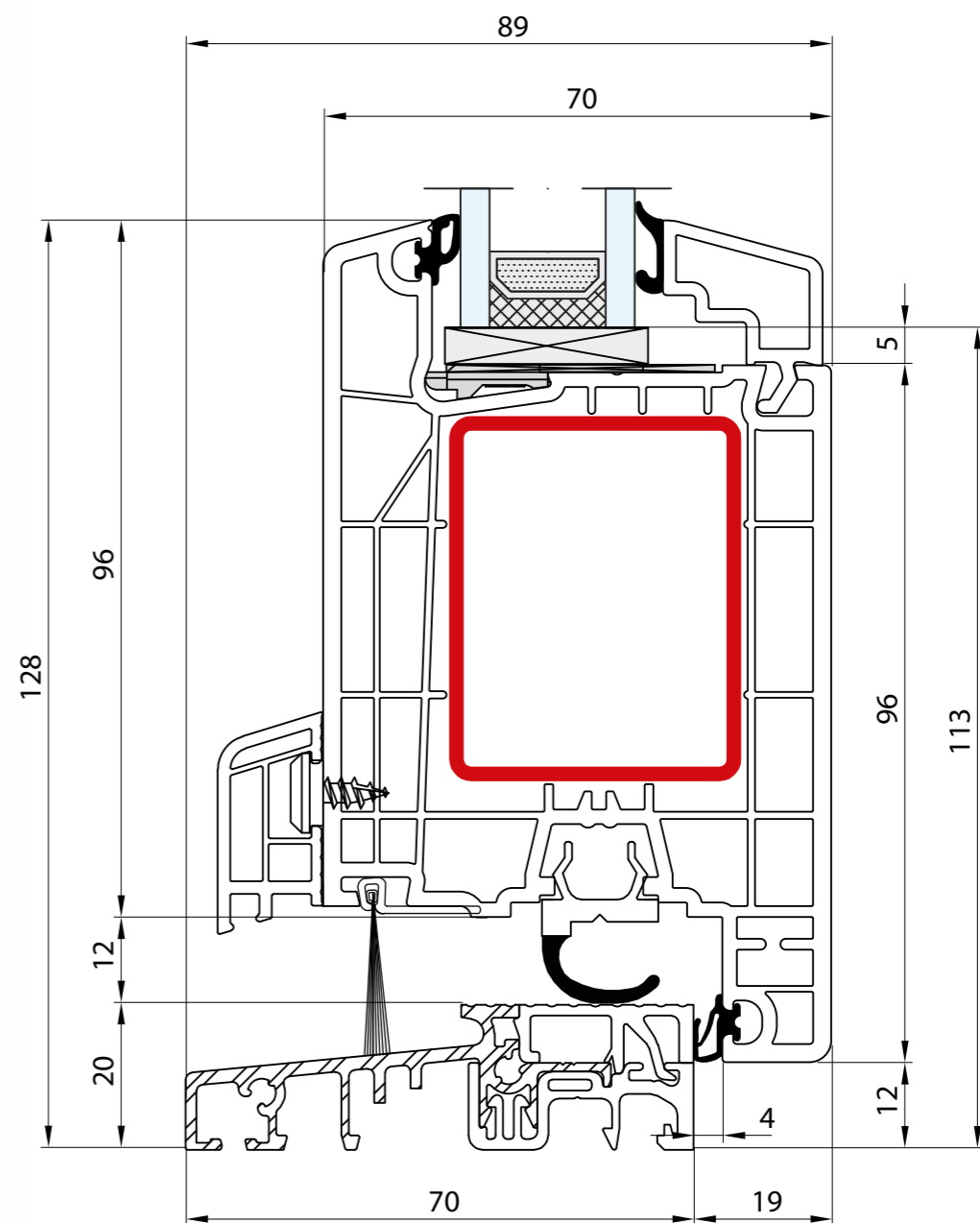
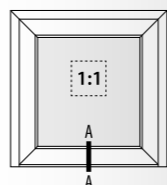

- Próg: 20 mm · Skrzydło: 116 mm
- Seuil: 20 mm · Vantail: 116 mm
- Threshold: 20 mm · Sash: 116 mm
- Schwelle: 20 mm · Flügel: 116 mm
- Soglia: 20 mm · Anta: 116 mm

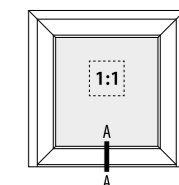

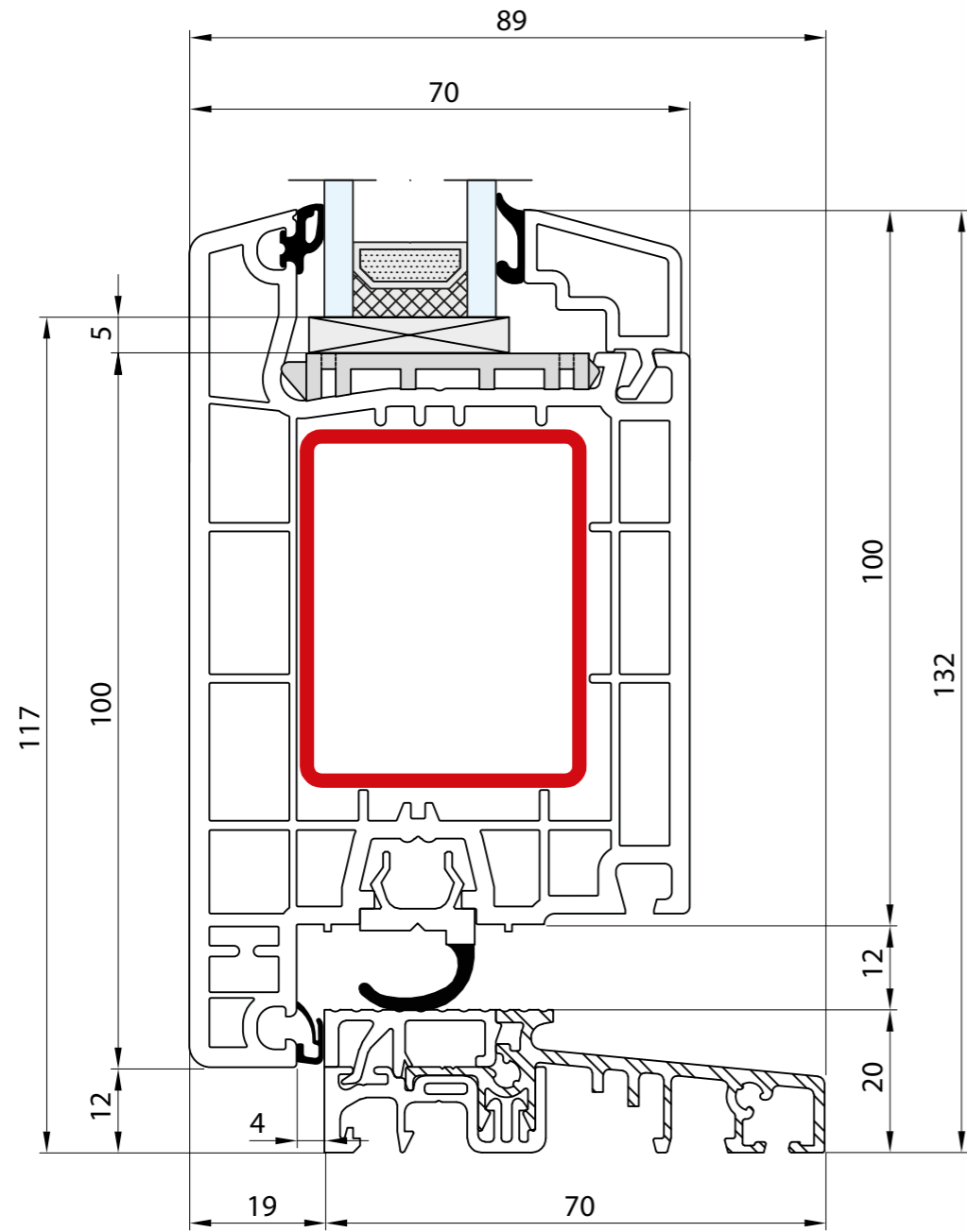

- Próg: 20 mm · Skrzydło: 120 mm
- Seuil: 20 mm · Vantail: 120 mm
- Threshold: 20 mm · Sash: 120 mm
- Schwelle: 20 mm · Flügel: 120 mm
- Soglia: 20 mm · Anta: 120 mm

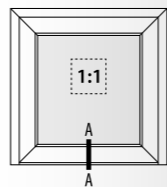

IDEAL 4000 NEW

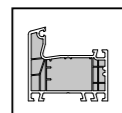
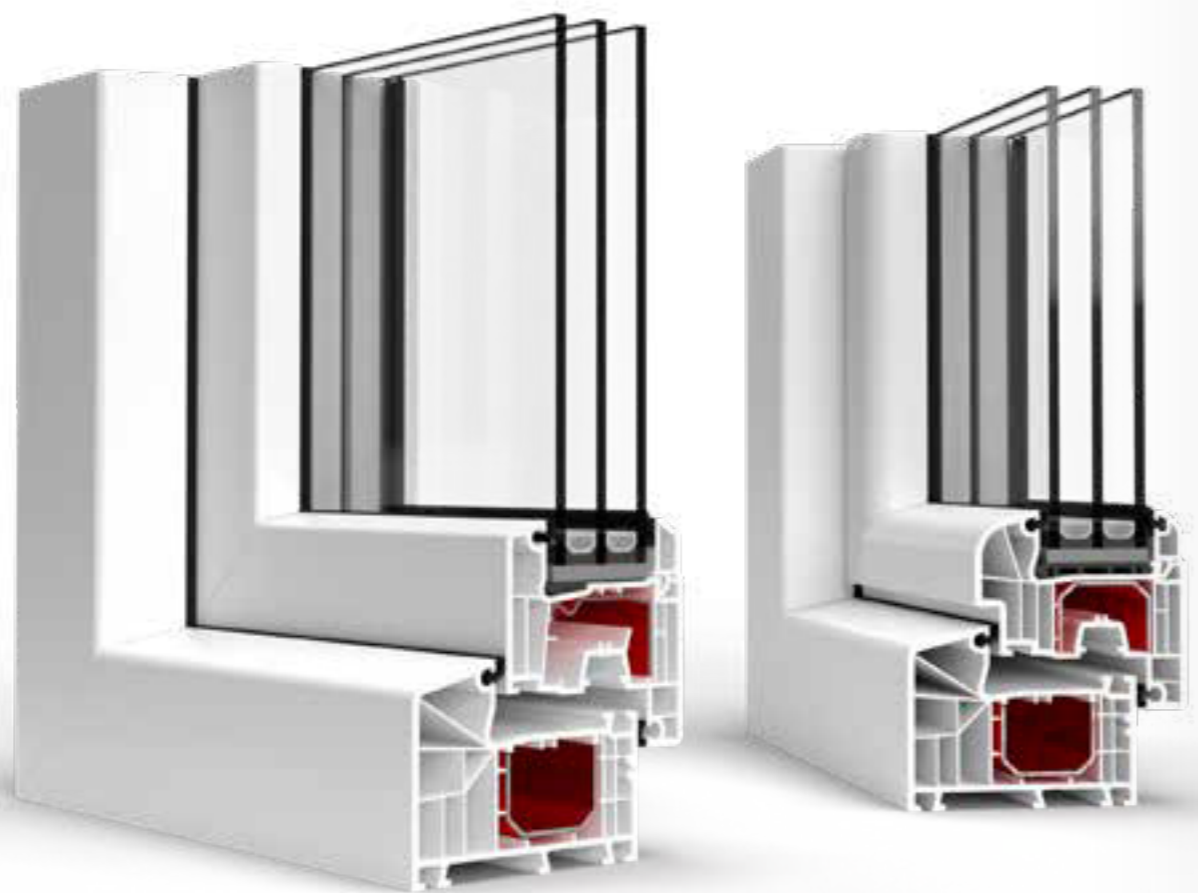

6



2

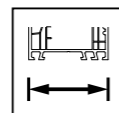

85

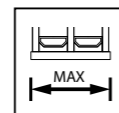

42

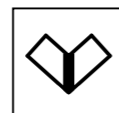

V-SUPER SOLUTION

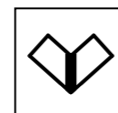

V-PERFECT TECHNOLOGY



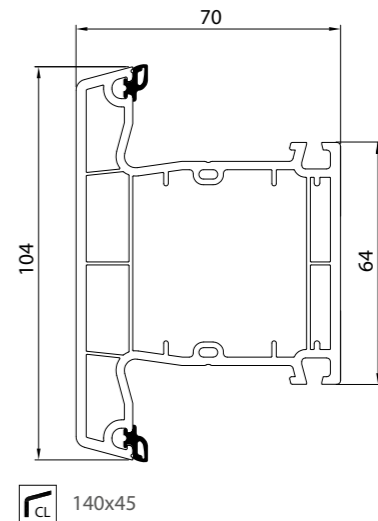
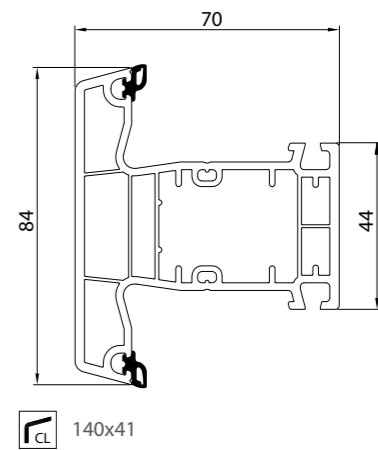
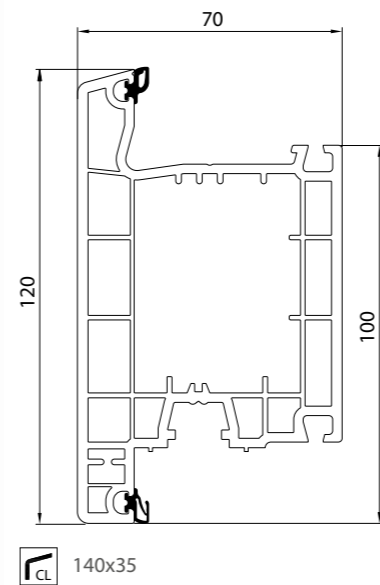
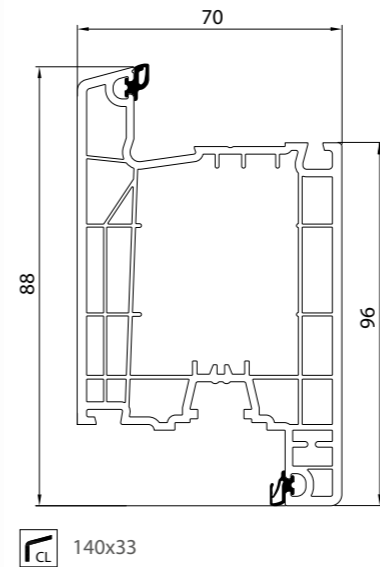
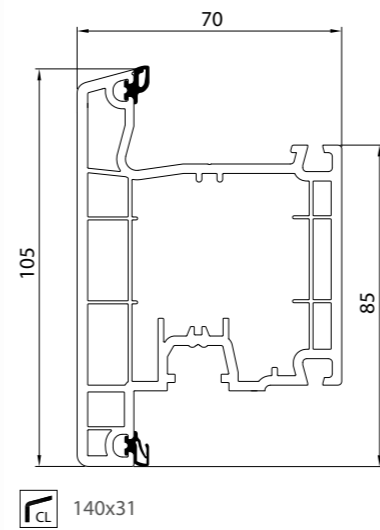
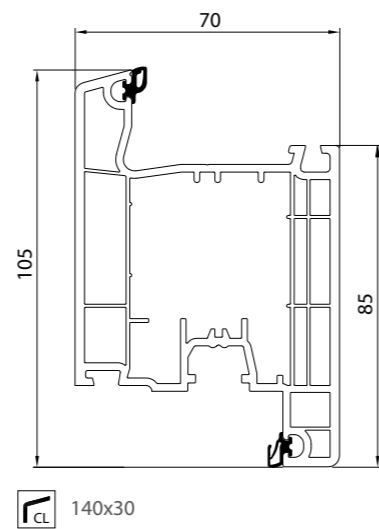
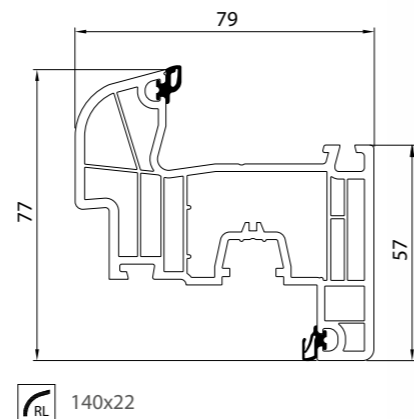
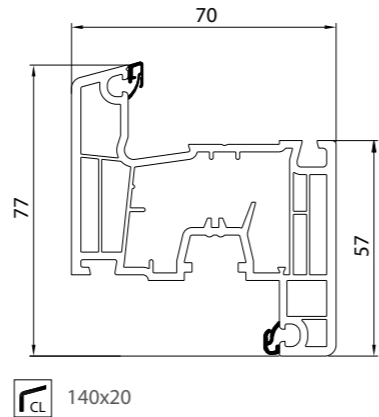
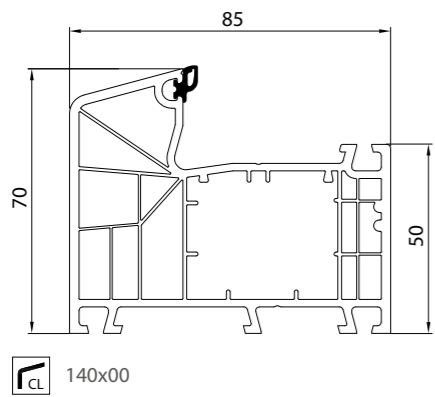

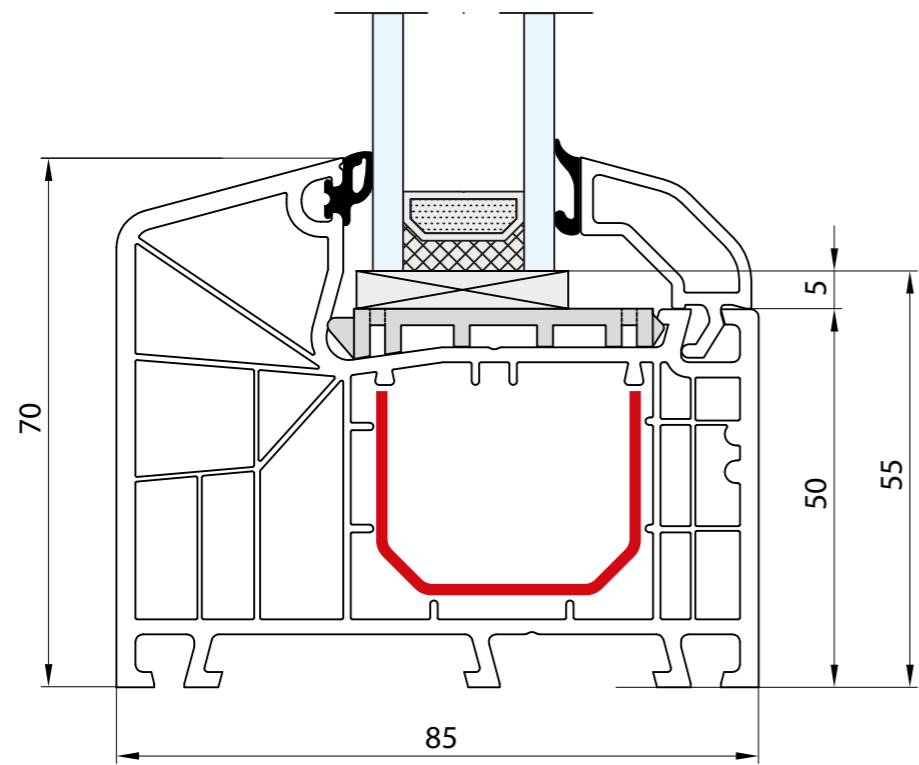

- Rama: 70 mm
- Dormant: 70 mm
- Frame: 70 mm
- Rahmen: 70 mm
- Telaio: 70 mm

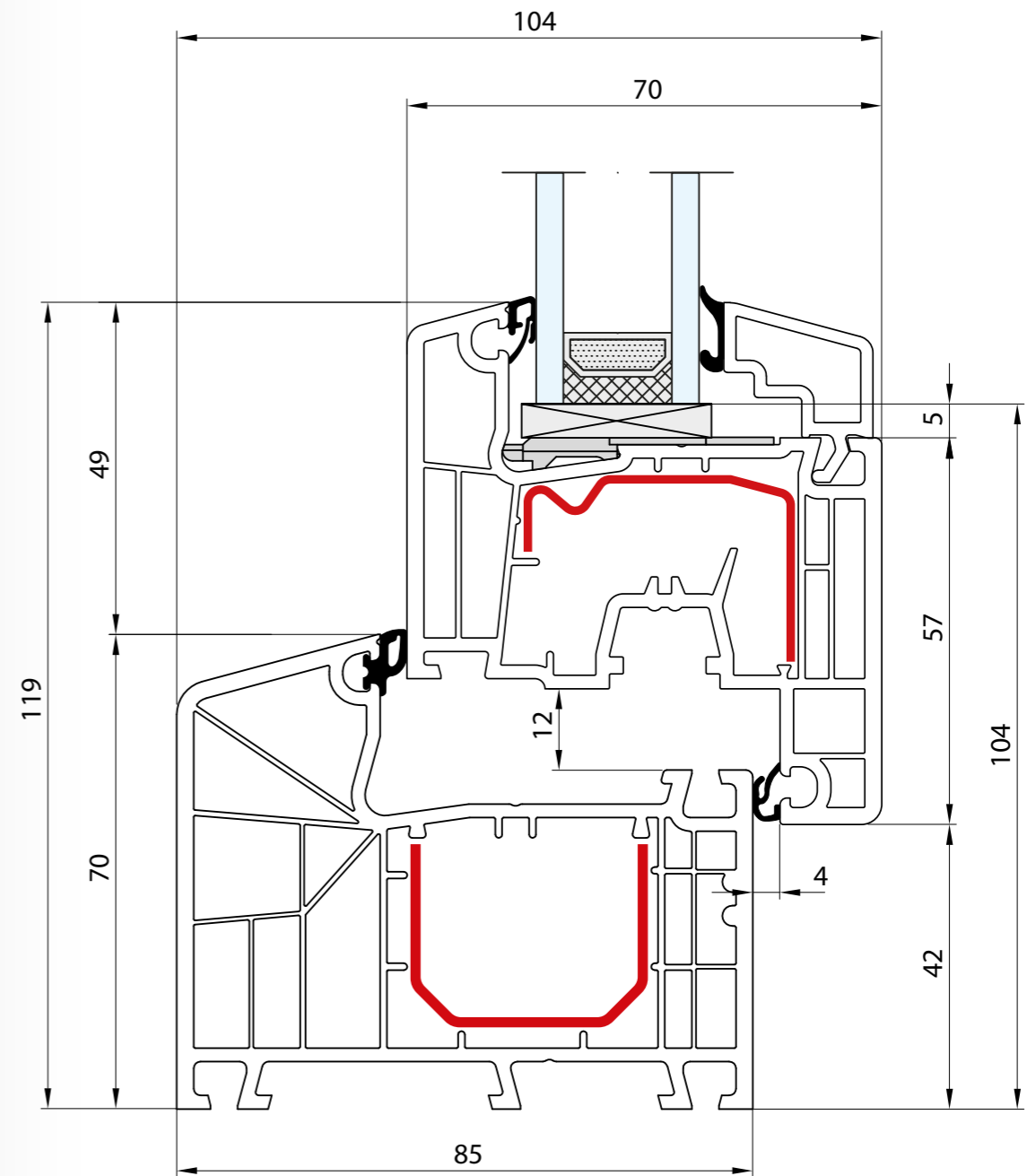
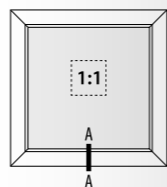

- Rama: 70 mm · Skrzydło: 77 mm
- Dormant: 70 mm · Vantail: 77 mm
- Frame: 70 mm · Sash: 77 mm
- Rahmen: 70 mm · Flügel: 77 mm
- Telaio: 70 mm · Anta: 77 mm

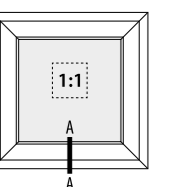

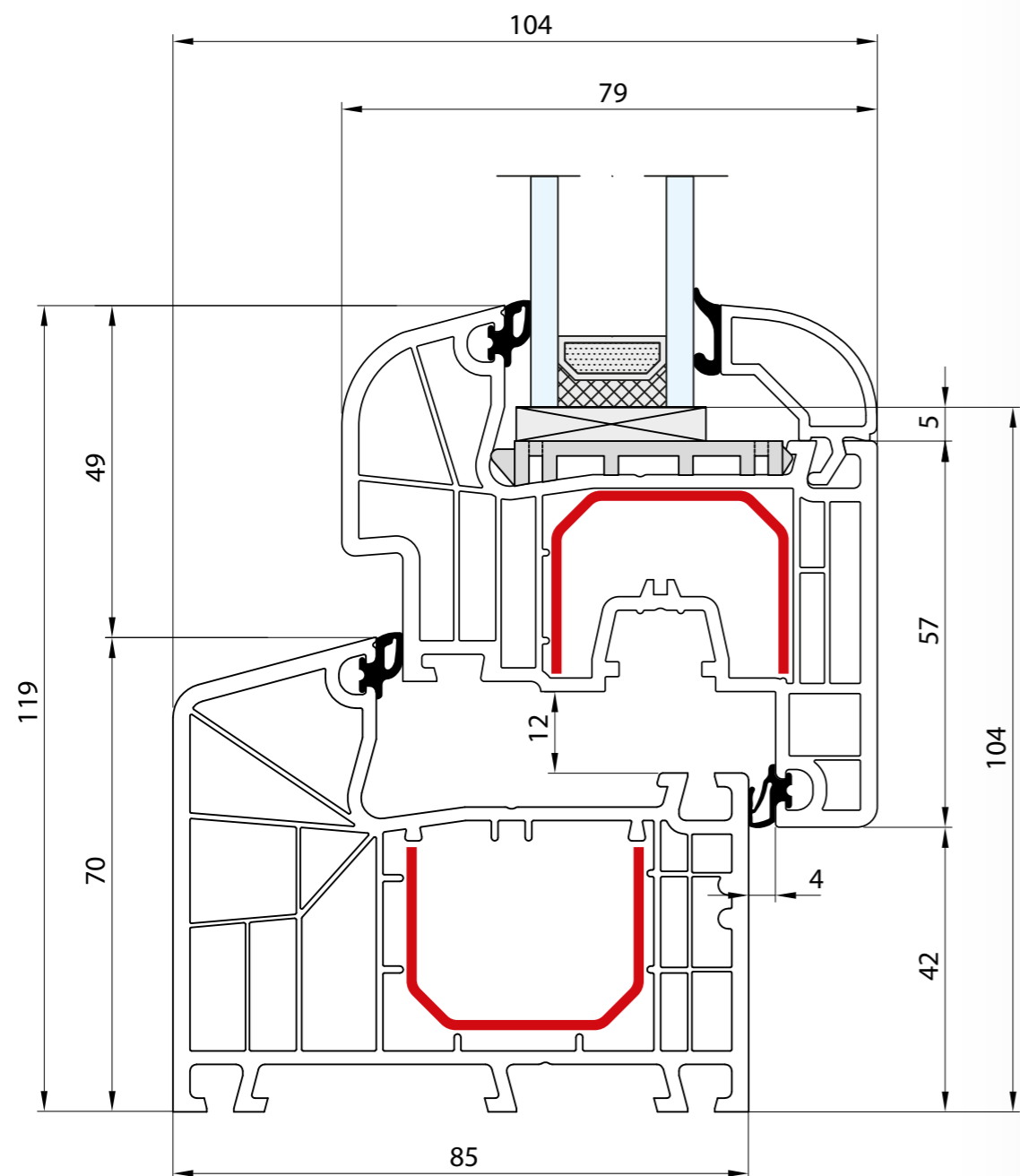

- Rama: 70 mm · Skrzydło: 77 mm
- Dormant: 70 mm · Vantail: 77 mm
- Frame: 70 mm · Sash: 77 mm
- Rahmen: 70 mm · Flügel: 77 mm
- Telaio: 70 mm · Anta: 77 mm

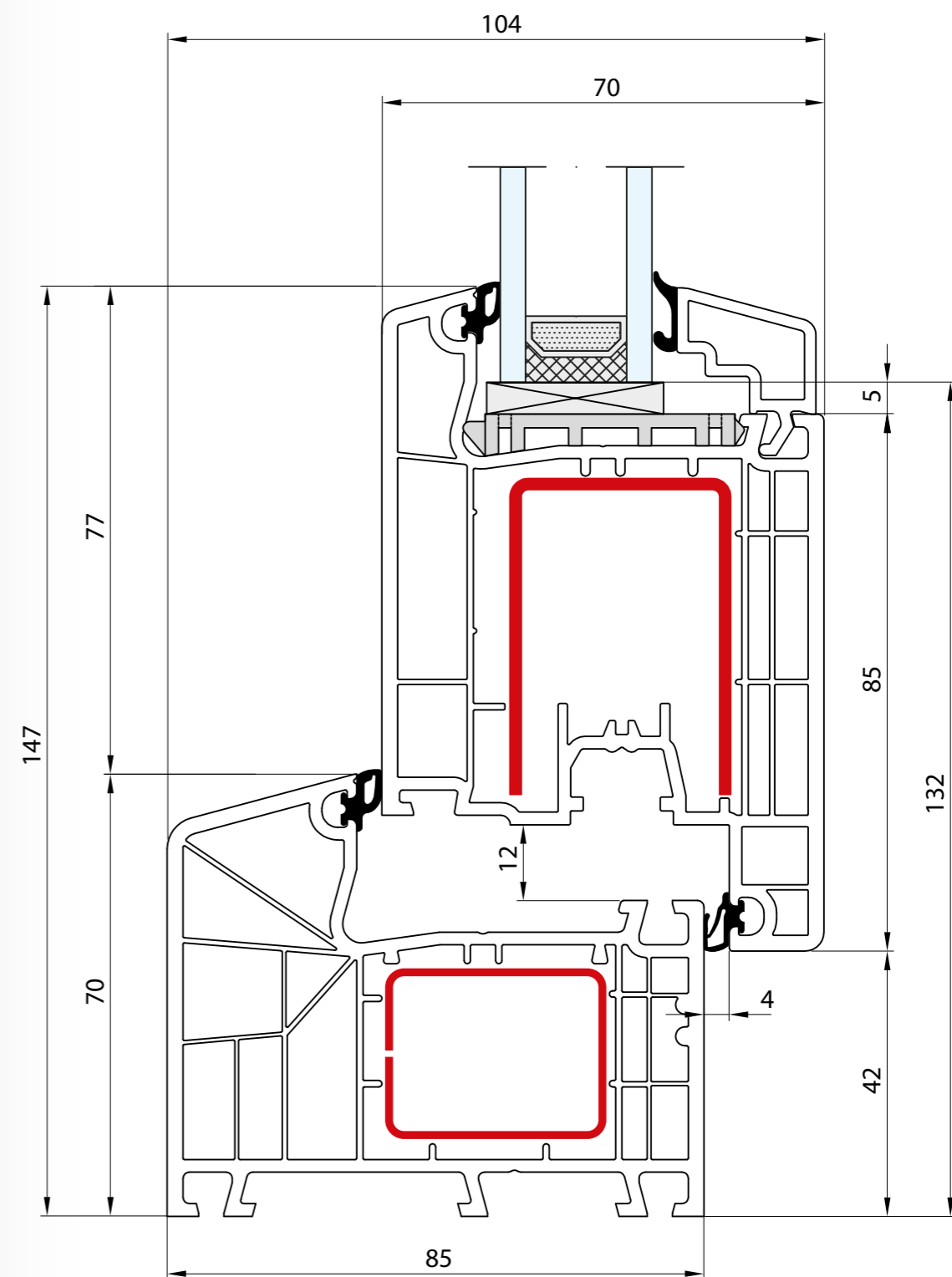
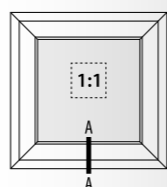

- Rama: 70 mm · Skrzydło: 105 mm
- Dormant: 70 mm · Vantail: 105 mm
- Frame: 70 mm · Sash: 105 mm
- Rahmen: 70 mm · Flügel: 105 mm
- Telaio: 70 mm · Anta: 105 mm

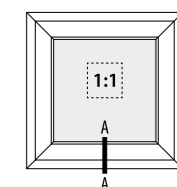

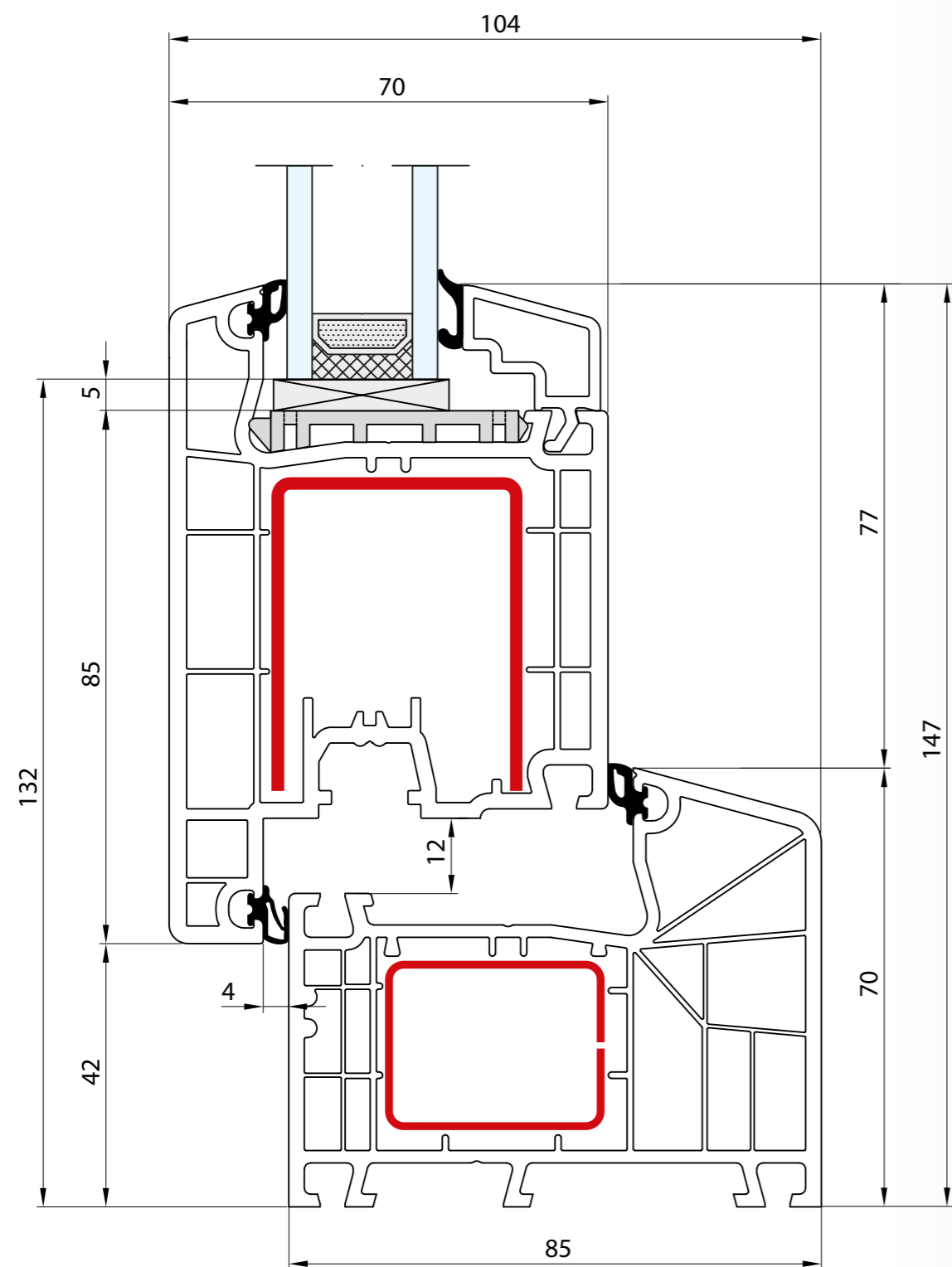

- Rama: 70 mm · Skrzydło: 105 mm
- Dormant: 70 mm · Vantail: 105 mm
- Frame: 70 mm · Sash: 105 mm
- Rahmen: 70 mm · Flügel: 105 mm
- Telaio: 70 mm · Anta: 105 mm

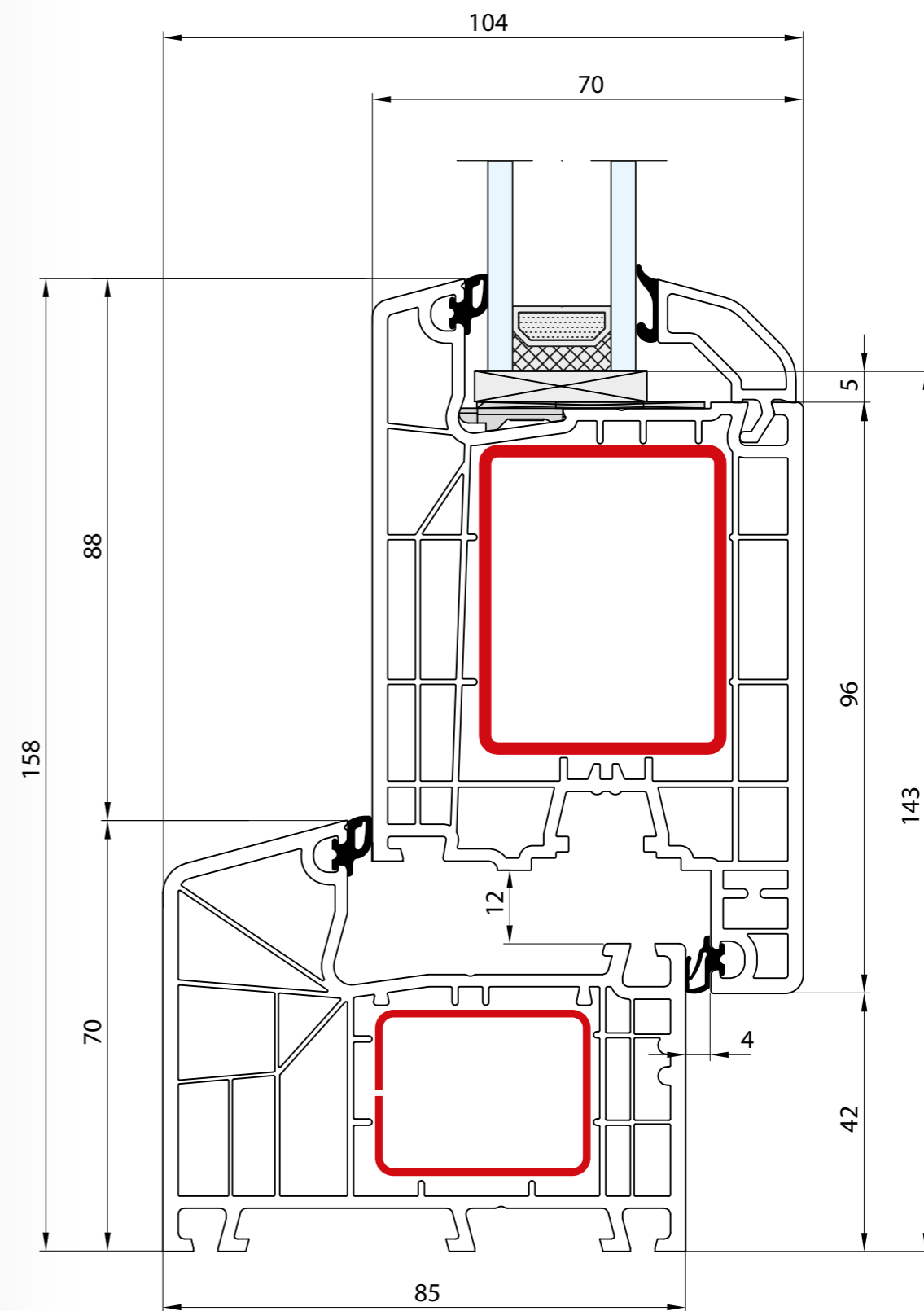
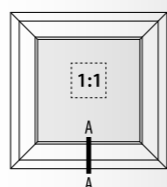

- Rama: 70 mm · Skrzydło: 116 mm
- Dormant: 70 mm · Vantail: 116 mm
- Frame: 70 mm · Sash: 116 mm
- Rahmen: 70 mm · Flügel: 116 mm
- Telaio: 70 mm · Anta: 116 mm

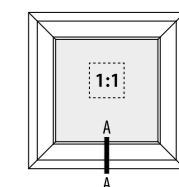

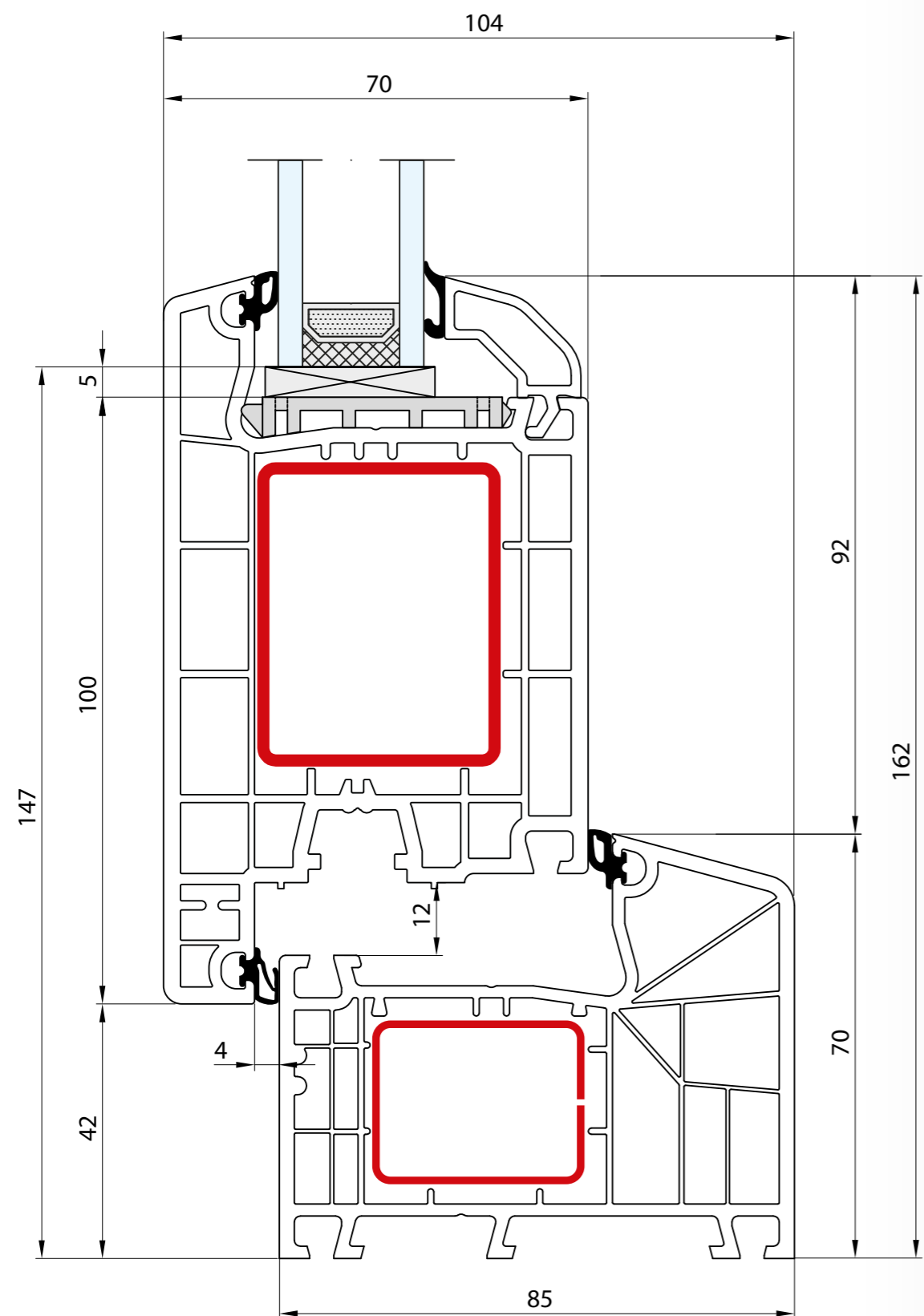

- Rama: 70 mm · Skrzydło: 120 mm
- Dormant: 70 mm · Vantail: 120 mm
- Frame: 70 mm · Sash: 120 mm
- Rahmen: 70 mm · Flügel: 120 mm
- Telaio: 70 mm · Anta: 120 mm

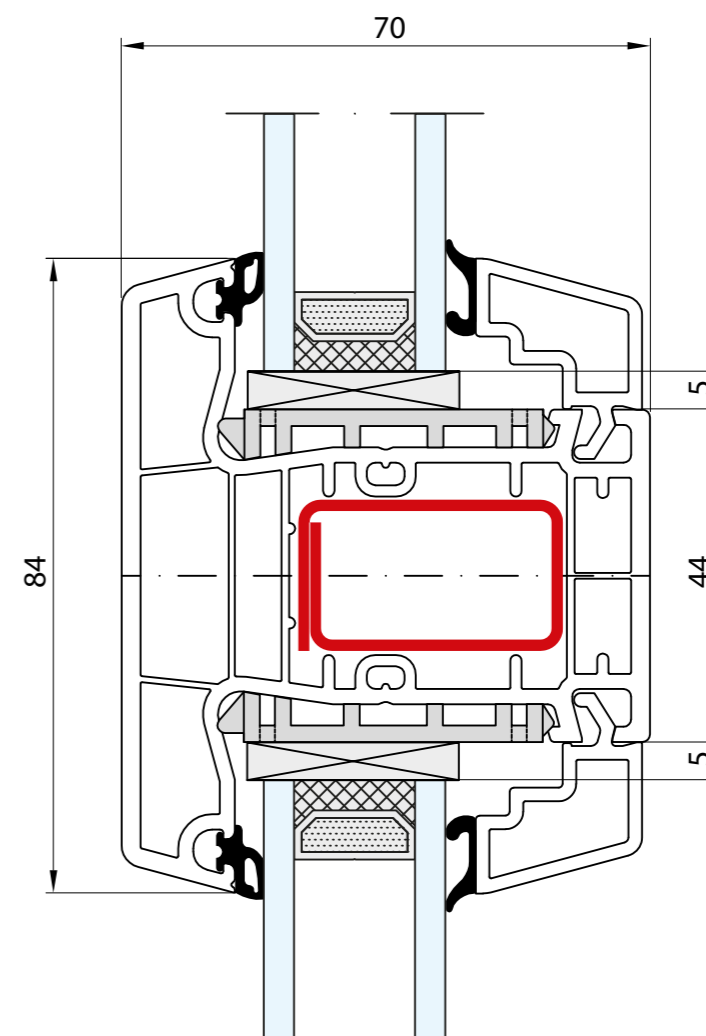
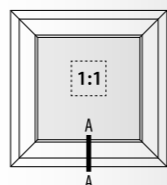

- Słupek stały: 84 mm
- Meneau fixe: 84 mm
- Fix post: 84 mm
- Festem Pfahl: 84 mm
- Montante fisso: 84 mm

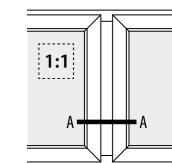

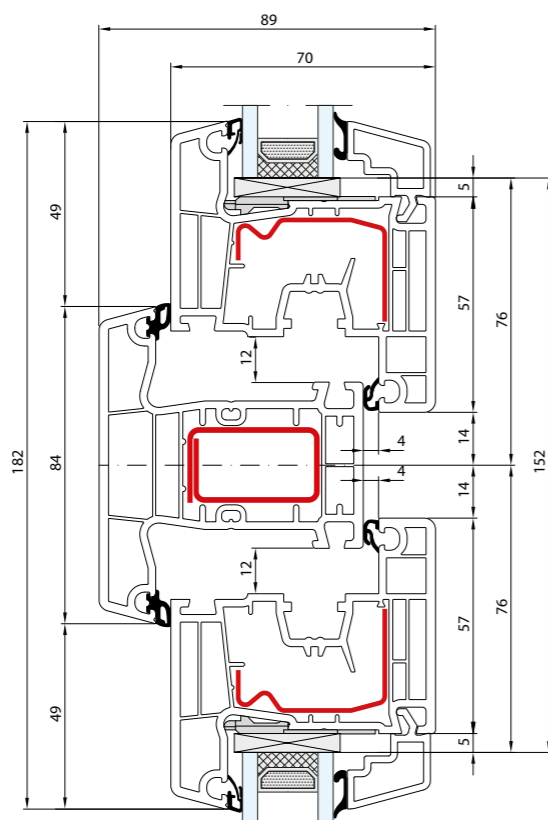



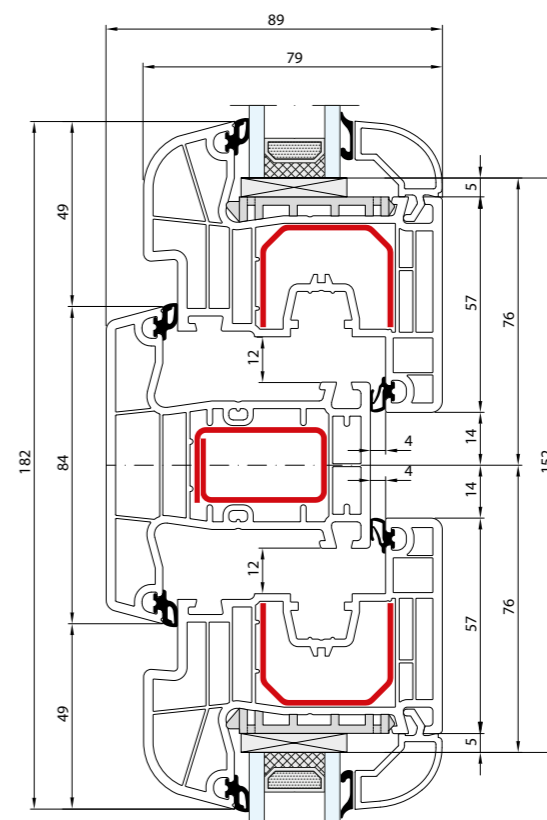
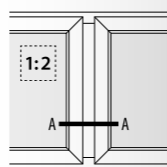

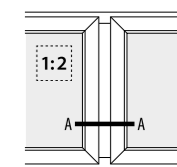

- Słupek stały: 84 mm · Skrzydło: 77 mm
- Meneau fixe: 84 mm · Vantail: 77 mm
- Fix post: 84 mm · Sash: 77 mm
- Festem Pfahl: 84 mm · Flügel: 77 mm
- Montante fisso: 84 mm · Anta: 77 mm

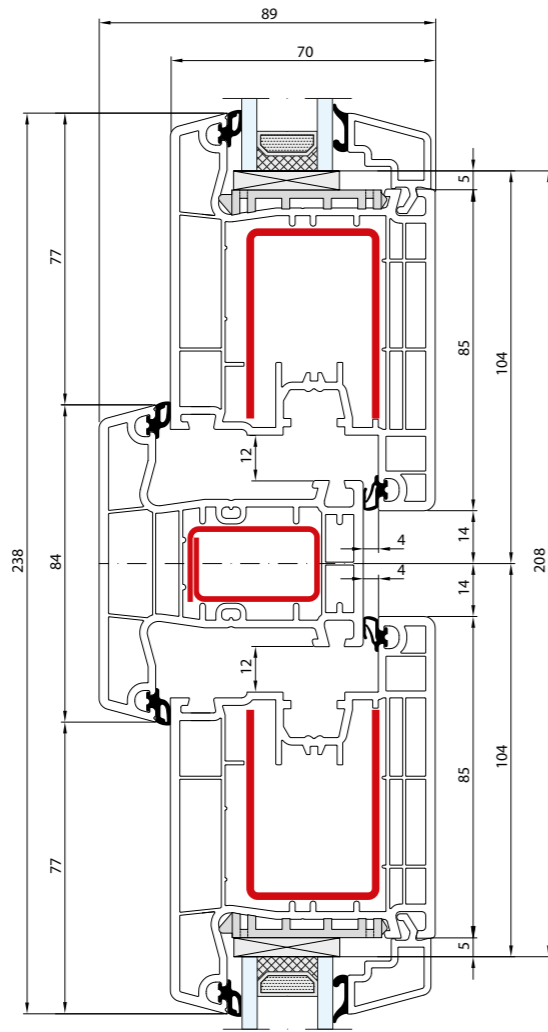







- Słupek stały: 84 mm · Skrzydło: 77 mm
- Meneau fixe: 84 mm · Vantail: 77 mm
- Fix post: 84 mm · Sash: 77 mm
- Festem Pfahl: 84 mm · Flügel: 77 mm
- Montante fisso: 84 mm · Anta: 77 mm

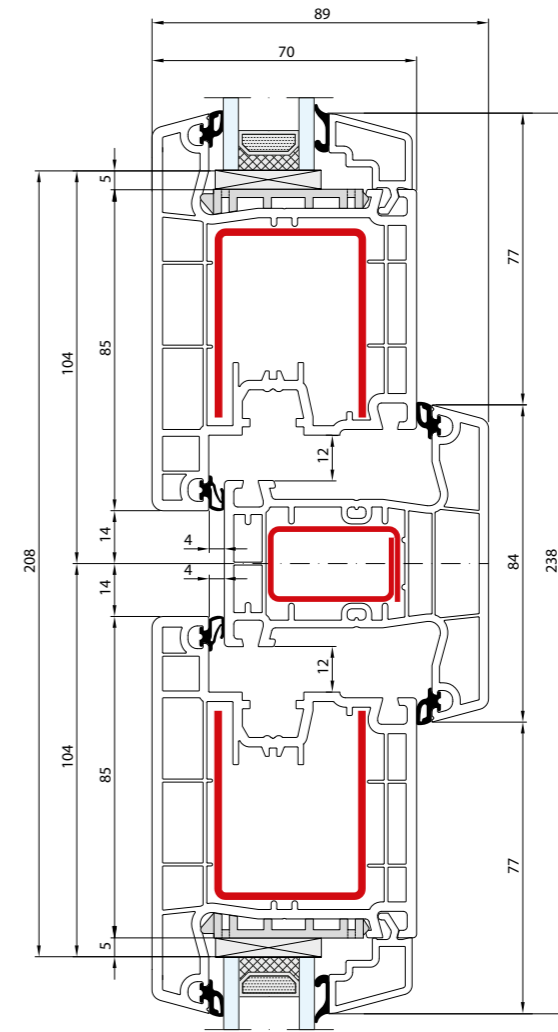
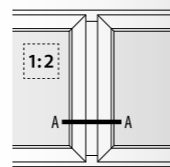



-  Słupek stały: 84 mm · Skrzydło: 105 mm
-  Meneau fixe: 84 mm · Vantail: 105 mm
-  Fix post: 84 mm · Sash: 105 mm
-  Festem Pfahl: 84 mm · Flügel: 105 mm
-  Montante fisso: 84 mm · Anta: 105 mm



-  Słupek stały: 84 mm · Skrzydło: 105 mm
-  Meneau fixe: 84 mm · Vantail: 105 mm
-  Fix post: 84 mm · Sash: 105 mm
-  Festem Pfahl: 84 mm · Flügel: 105 mm
-  Montante fisso: 84 mm · Anta: 105 mm

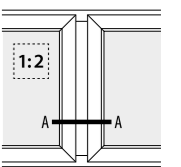

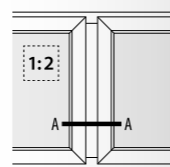
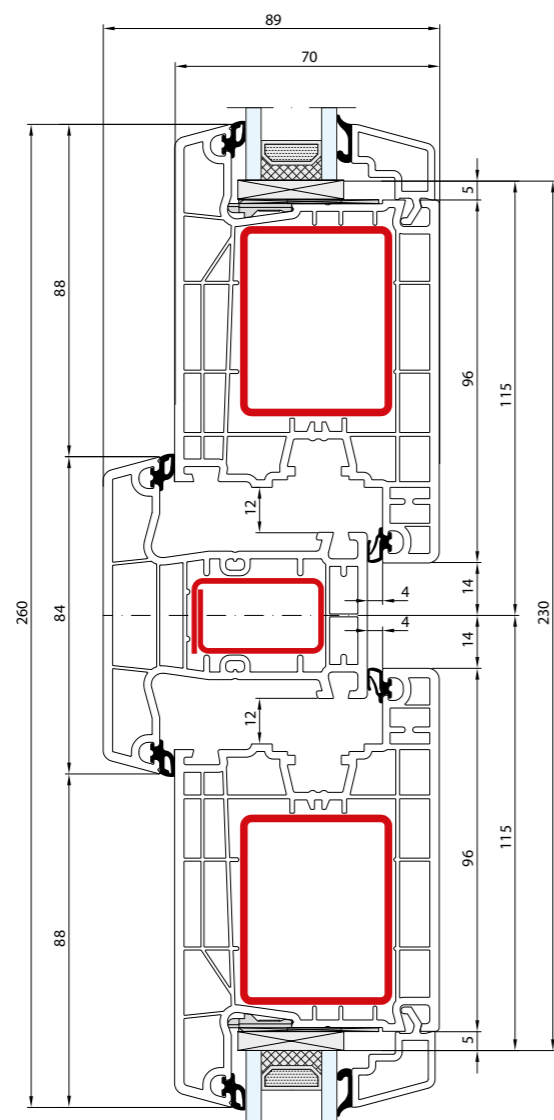

- Słupek stały: 84 mm · Skrzydło: 116 mm
- Meneau fixe: 84 mm · Vantail: 116 mm
- Fix post: 84 mm · Sash: 116 mm
- Festem Pfahl: 84 mm · Flügel: 116 mm
- Montante fisso: 84 mm · Anta: 116 mm

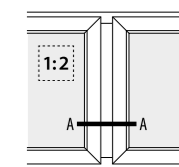
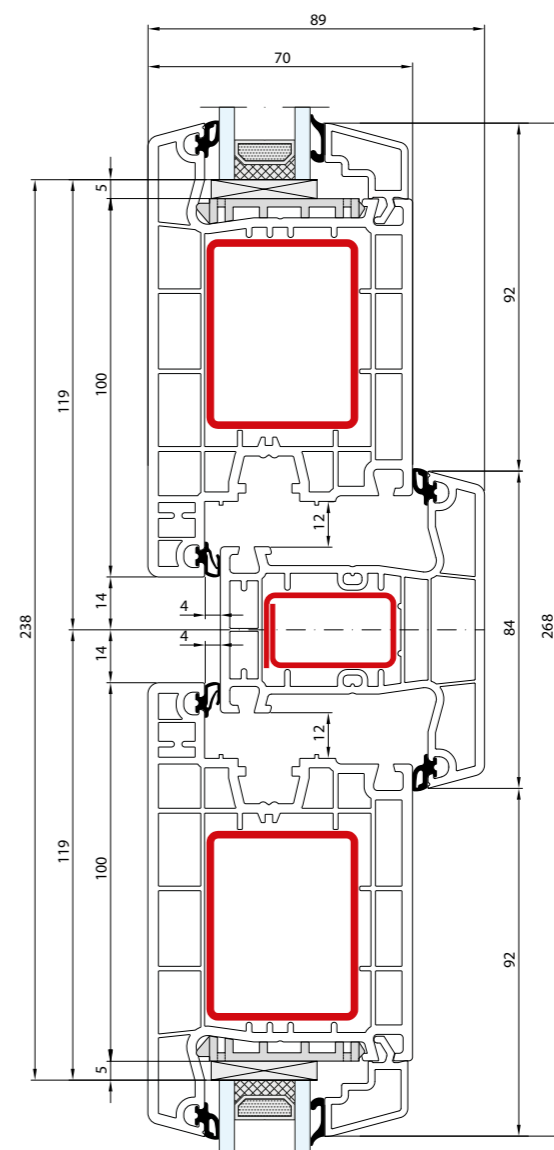

- Słupek stały: 84 mm · Skrzydło: 120 mm
- Meneau fixe: 84 mm · Vantail: 120 mm
- Fix post: 84 mm · Sash: 120 mm
- Festem Pfahl: 84 mm · Flügel: 120 mm
- Montante fisso: 84 mm · Anta: 120 mm

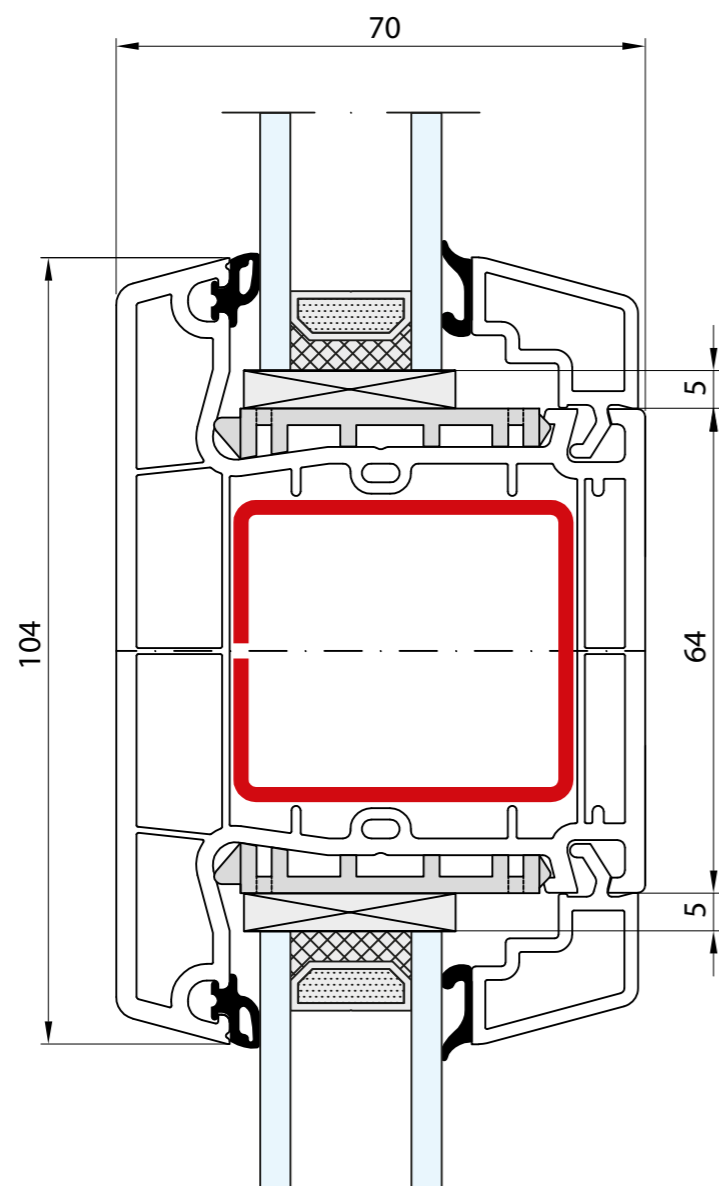

- Słupek stały: 104 mm
- Meneau fixe: 104 mm
- Fix post: 104 mm
- Festem Pfahl: 104 mm
- Montante fisso: 104 mm

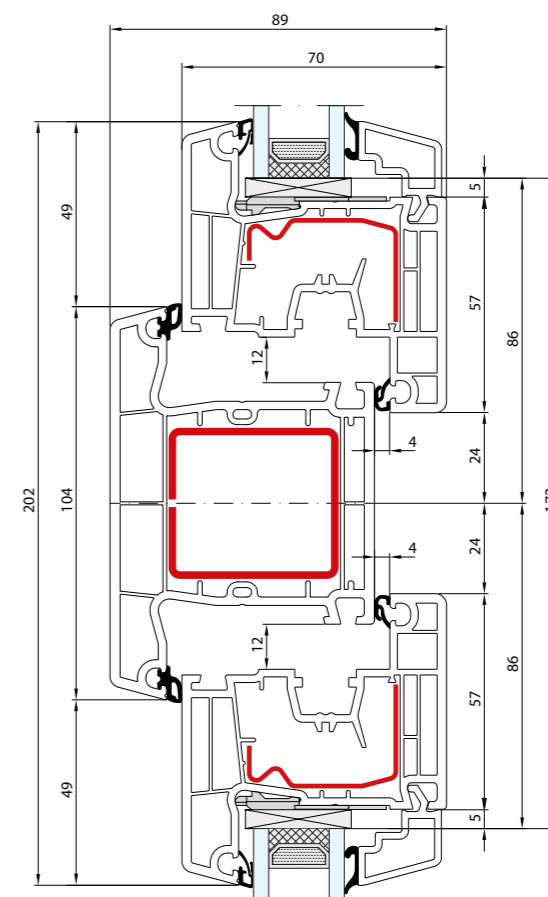
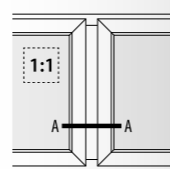

- Słupek stały: 104 mm · Skrzydło: 77 mm
- Meneau fixe: 104 mm · Vantail: 77 mm
- Fix post: 104 mm · Sash: 77 mm
- Festem Pfahl: 104 mm · Flügel: 77 mm
- Montante fisso: 104 mm · Anta: 77 mm

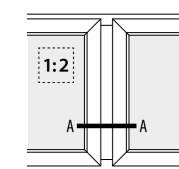

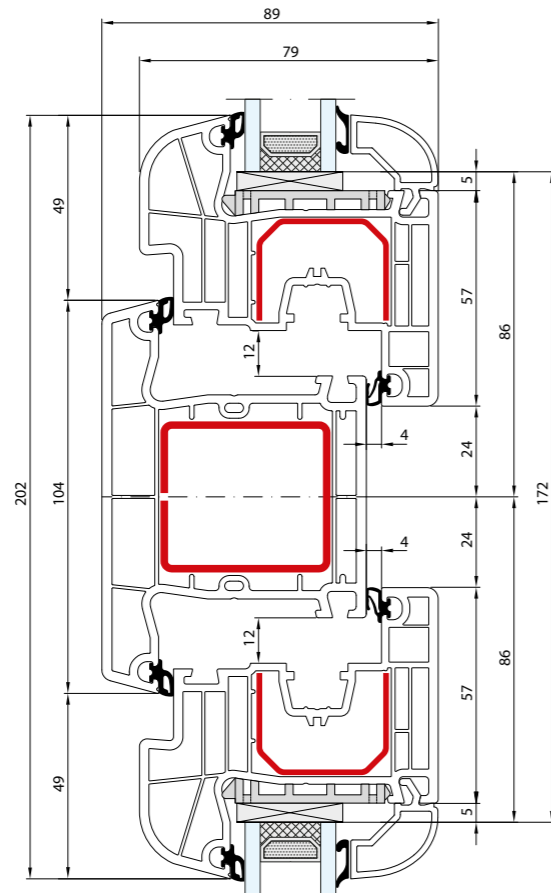

- Słupek stały: 104 mm · Skrzydło: 77 mm
- Meneau fixe: 104 mm · Vantail: 77 mm
- Fix post: 104 mm · Sash: 77 mm
- Festem Pfahl: 104 mm · Flügel: 77 mm
- Montante fisso: 104 mm · Anta: 77 mm

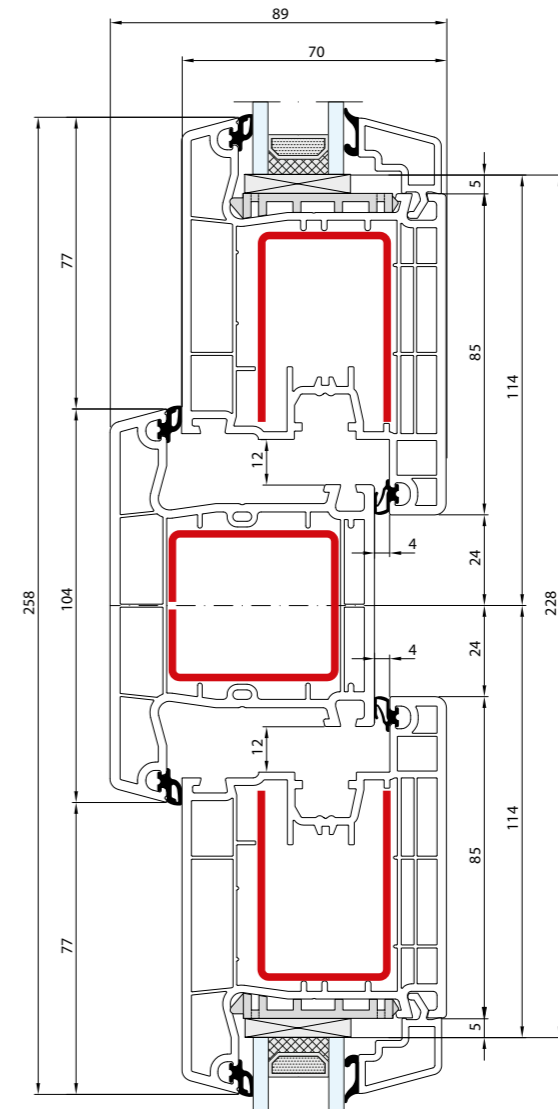
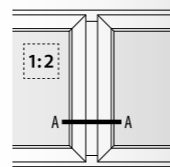

- Słupek stały: 104 mm · Skrzydło: 105 mm
- Meneau fixe: 104 mm · Vantail: 105 mm
- Fix post: 104 mm · Sash: 105 mm
- Festem Pfahl: 104 mm · Flügel: 105 mm
- Montante fisso: 104 mm · Anta: 105 mm

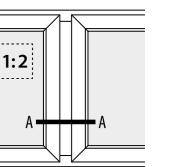

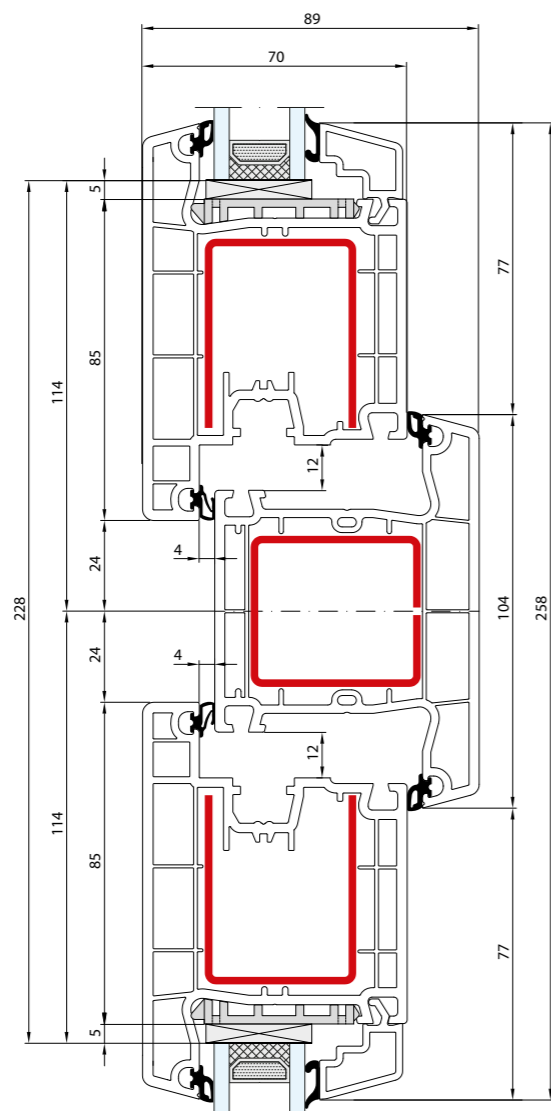

- Słupek stały: 104 mm · Skrzydło: 105 mm
- Meneau fixe: 104 mm · Vantail: 105 mm
- Fix post: 104 mm · Sash: 105 mm
- Festem Pfahl: 104 mm · Flügel: 105 mm
- Montante fisso: 104 mm · Anta: 105 mm

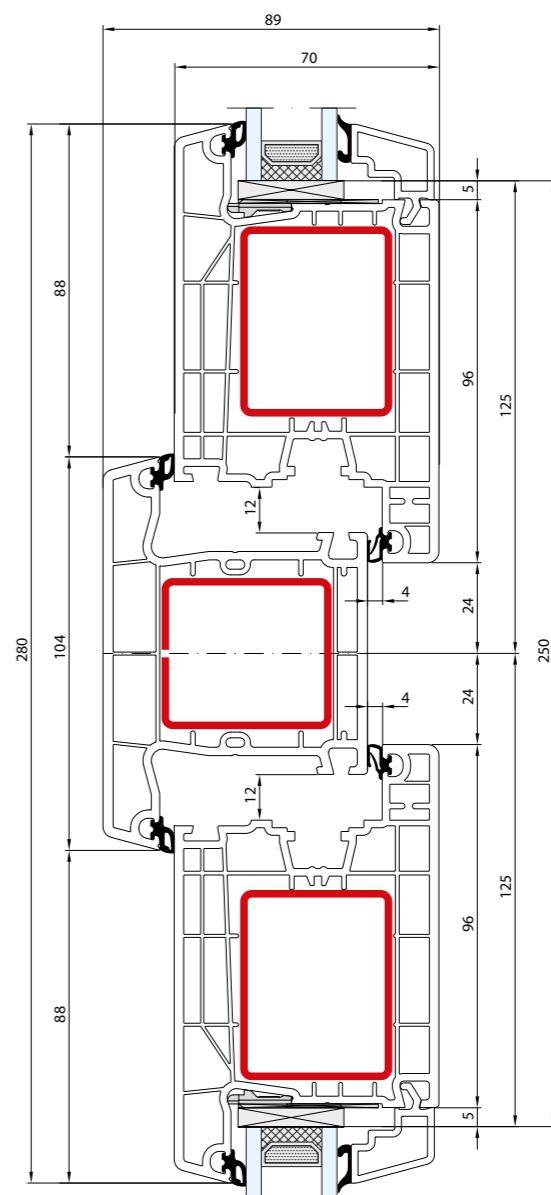
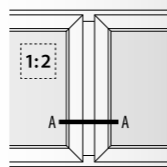

- Słupek stały: 104 mm · Skrzydło: 116 mm
- Meneau fixe: 104 mm · Vantail: 116 mm
- Fix post: 104 mm · Sash: 116 mm
- Festem Pfahl: 104 mm · Flügel: 116 mm
- Montante fisso: 104 mm · Anta: 116 mm

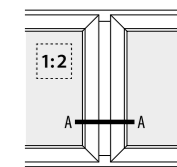

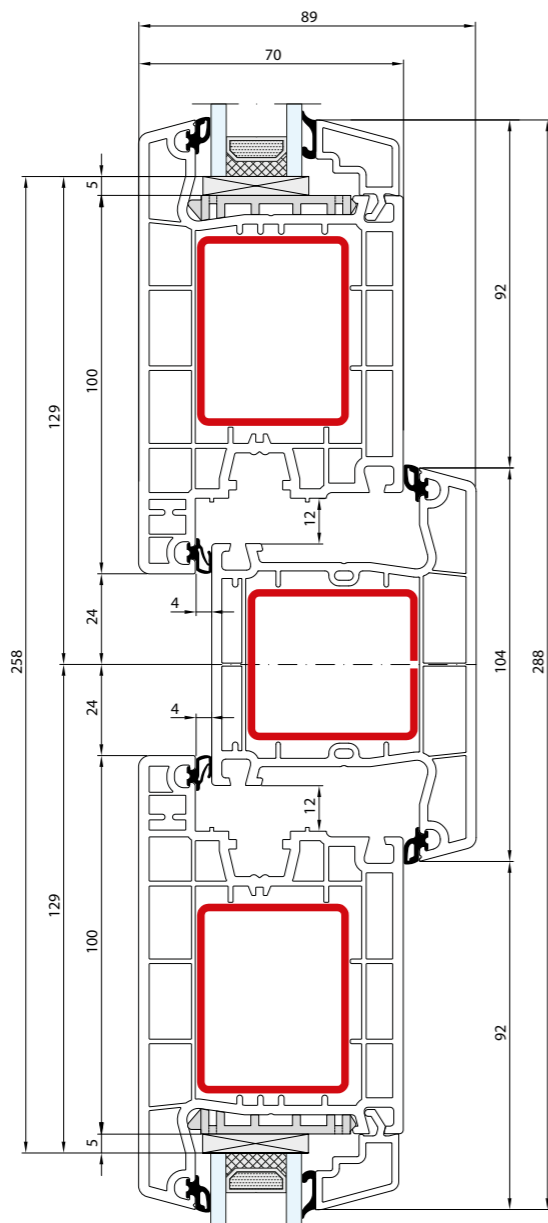

- Słupek stały: 104 mm · Skrzydło: 120 mm
- Meneau fixe: 104 mm · Vantail: 120 mm
- Fix post: 104 mm · Sash: 120 mm
- Festem Pfahl: 104 mm · Flügel: 120 mm
- Montante fisso: 104 mm · Anta: 120 mm

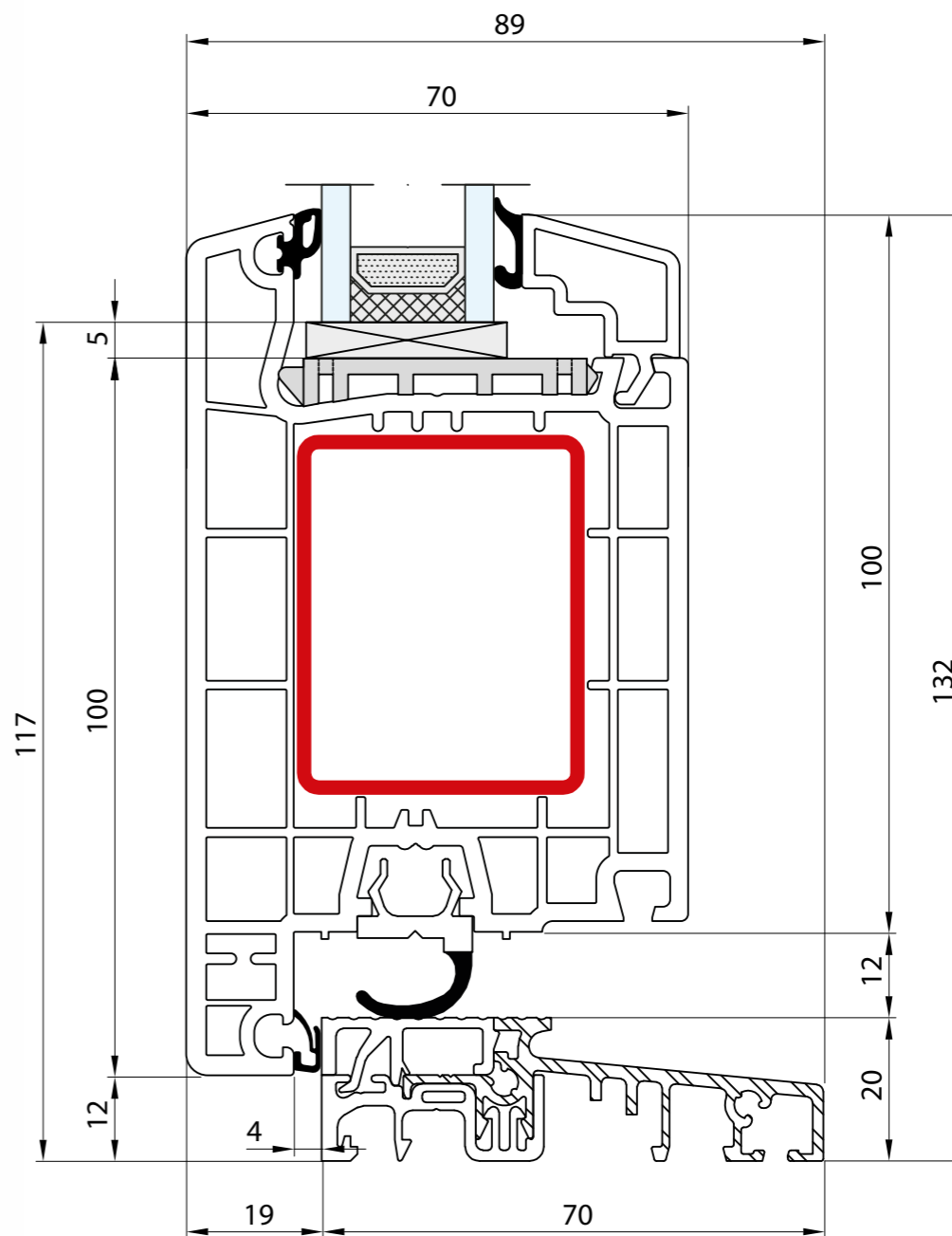
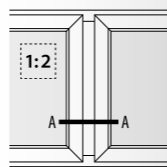

- Próg: 20 mm · Skrzydło: 120 mm
- Seuil: 20 mm · Vantail: 120 mm
- Threshold: 20 mm · Sash: 120 mm
- Schwelle: 20 mm · Flügel: 120 mm
- Soglia: 20 mm · Anta: 120 mm

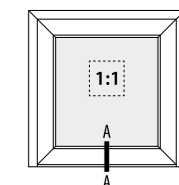

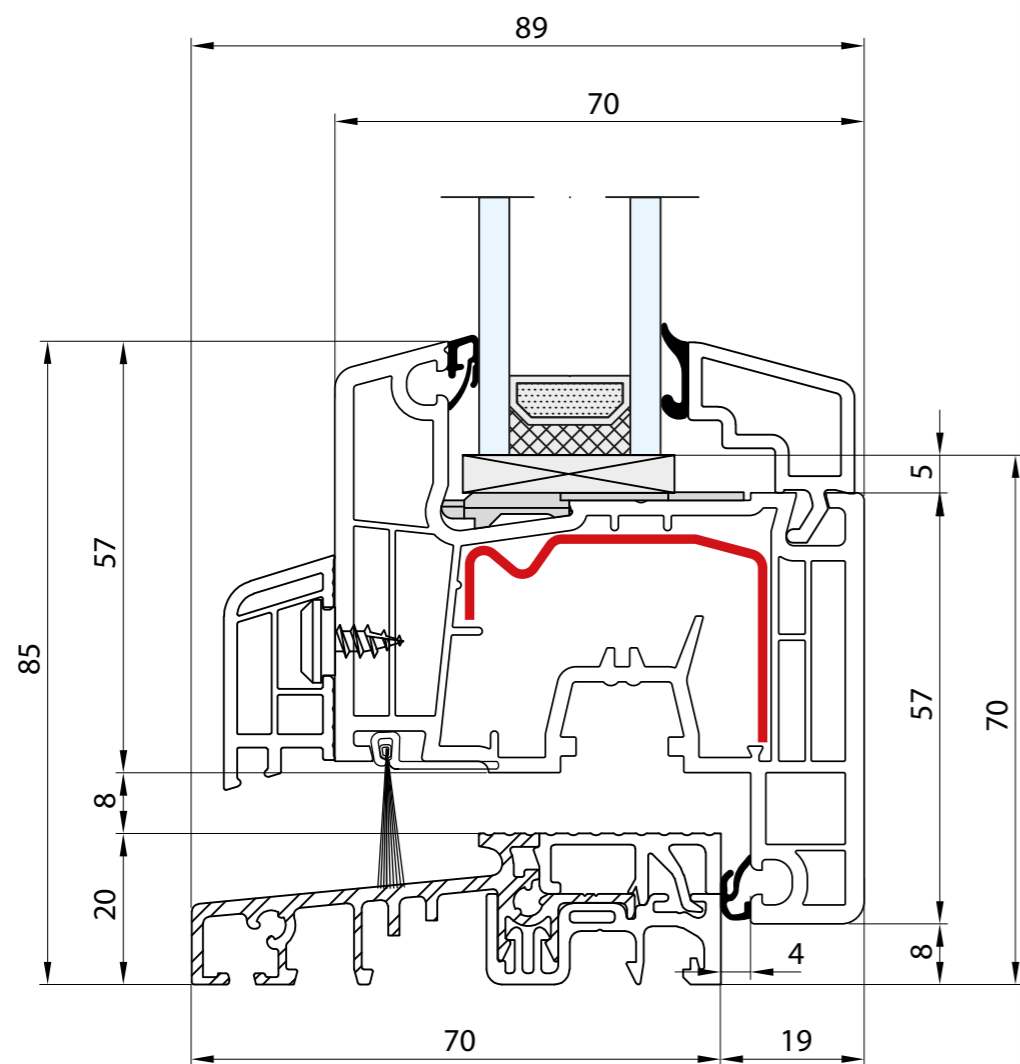

- Próg: 20 mm · Skrzydło: 77 mm
- Seuil: 20 mm · Vantail: 77 mm
- Threshold: 20 mm · Sash: 77 mm
- Schwelle: 20 mm · Flügel: 77 mm
- Soglia: 20 mm · Anta: 77 mm

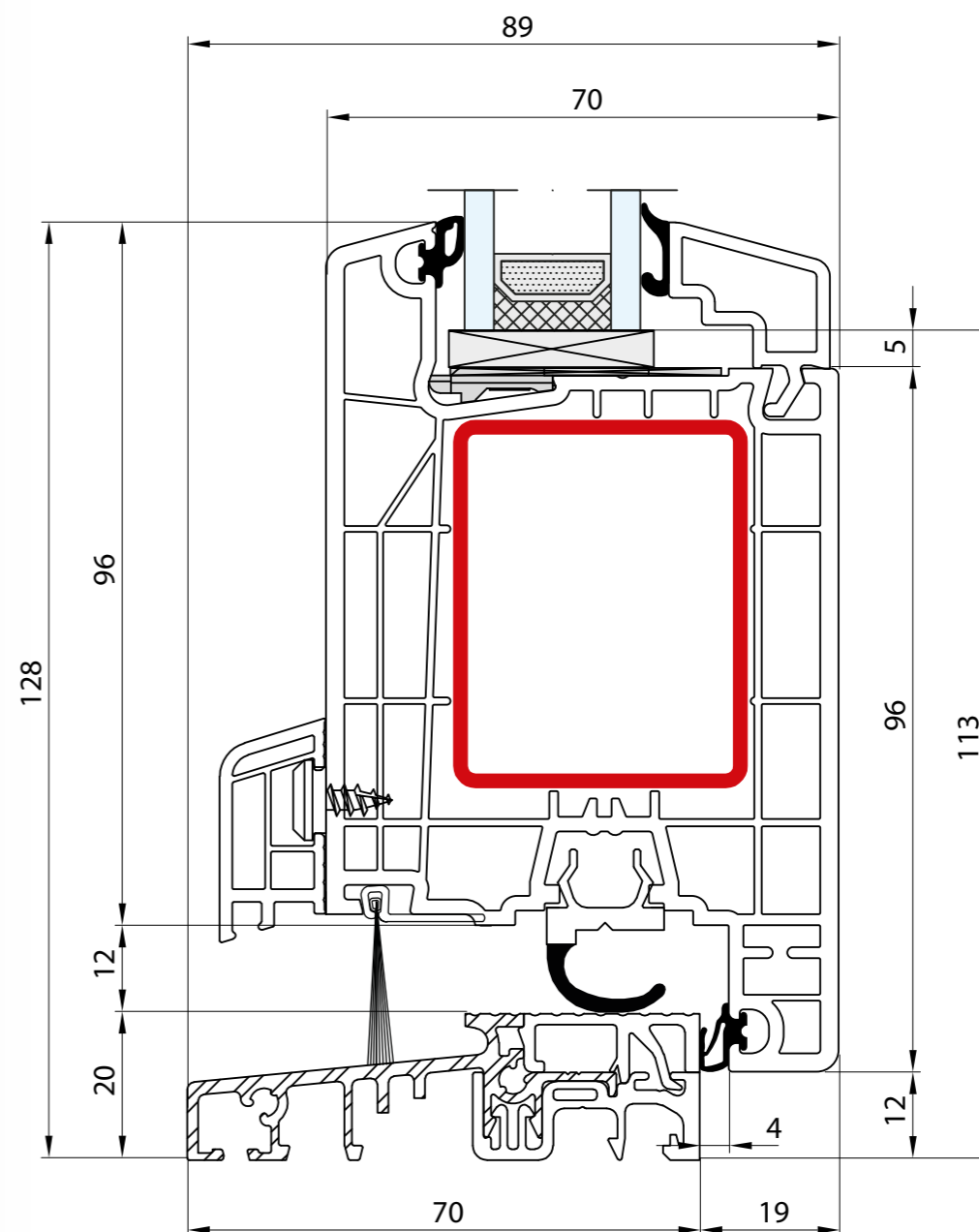
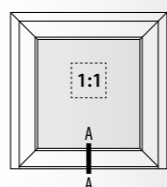

- Próg: 20 mm · Skrzydło: 116 mm
- Seuil: 20 mm · Vantail: 116 mm
- Threshold: 20 mm · Sash: 116 mm
- Schwelle: 20 mm · Flügel: 116 mm
- Soglia: 20 mm · Anta: 116 mm

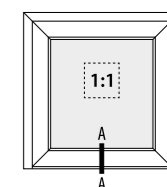

IDEAL 5000

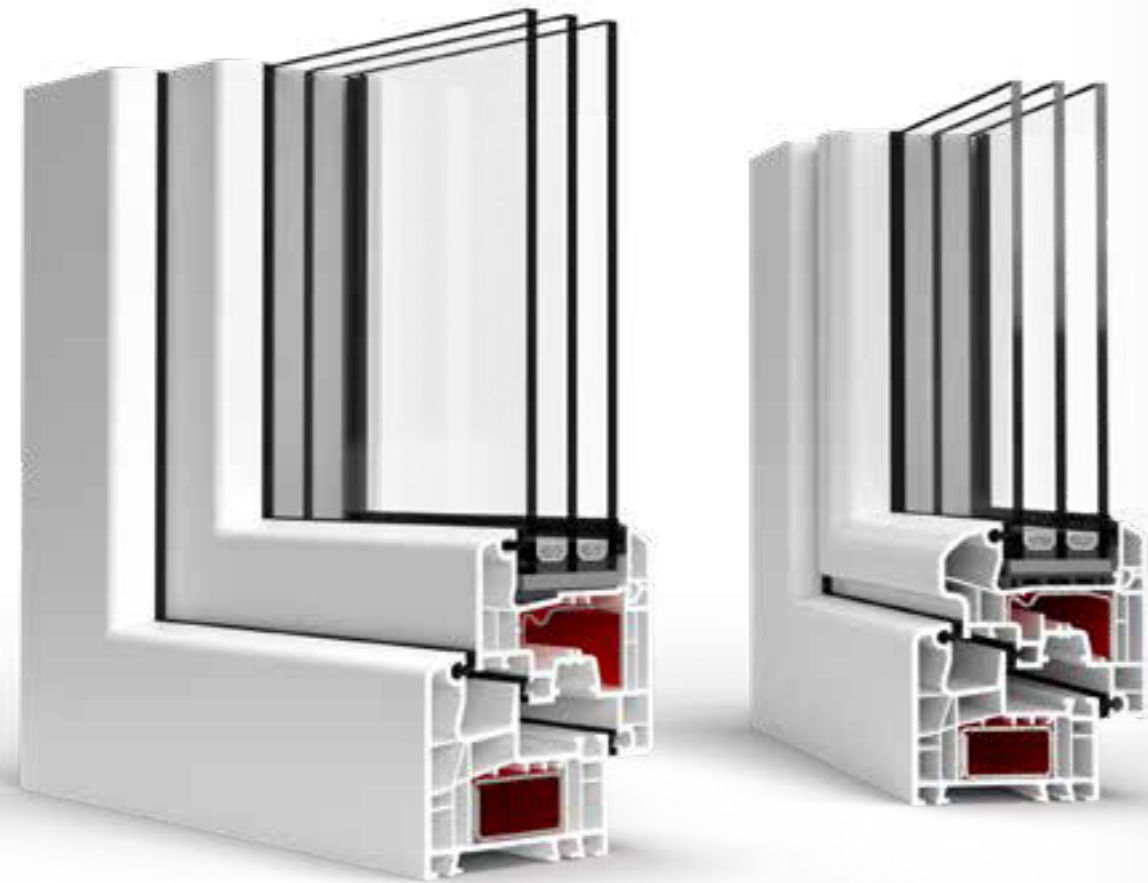

- 5**
- 3**
- 70**
- 42**
- SUPER SOLUTION**
- V-PERFECT TECHNOLOGY**
- ALU**



IDEAL 4000
 IDEAL 0000 NEW
 IDEAL 5000 +
 IDEAL 7000 NEW
 IDEAL 8000
 ENERGETO 8000

IDEAL 4000
 IDEAL 4000 NEW
 IDEAL 5000 +
 IDEAL 7000 NEW
 IDEAL 8000
 ENERGETO 8000

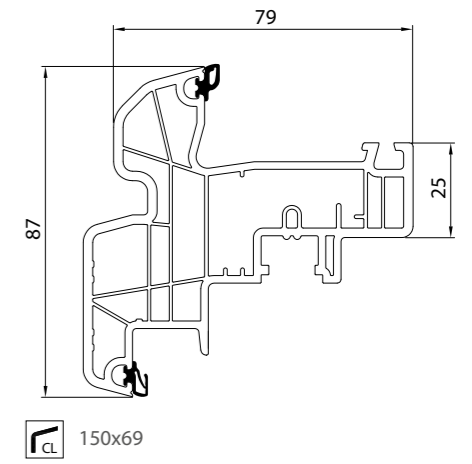
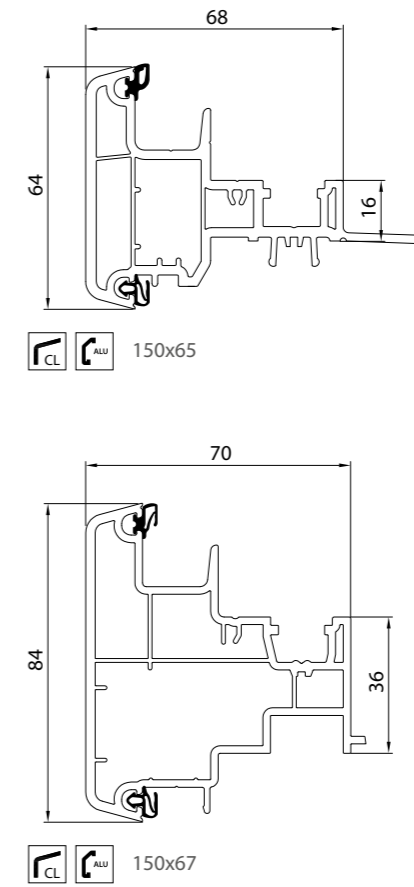
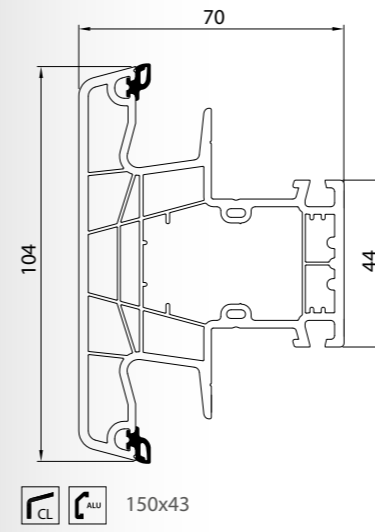
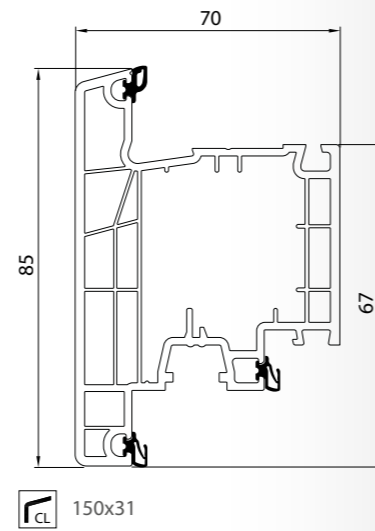
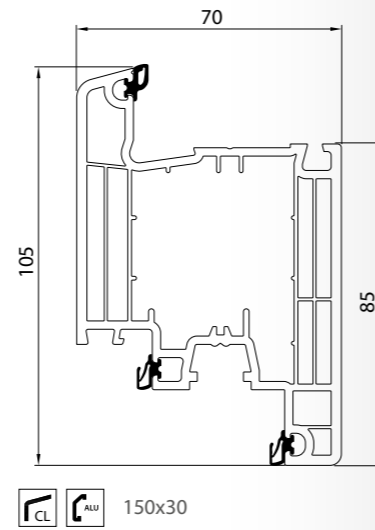
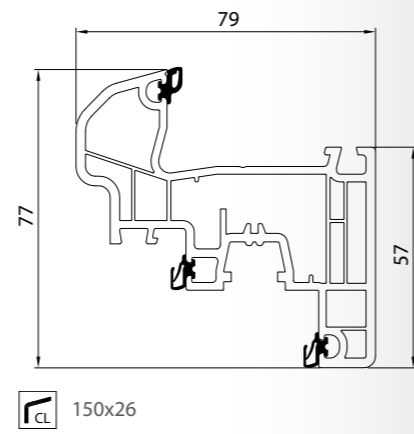
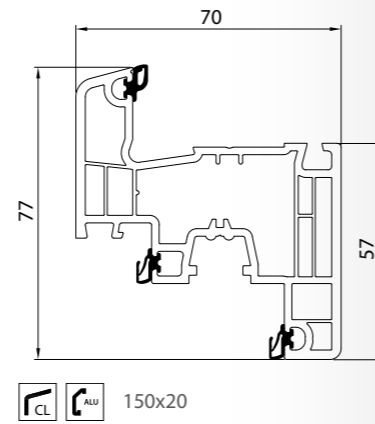
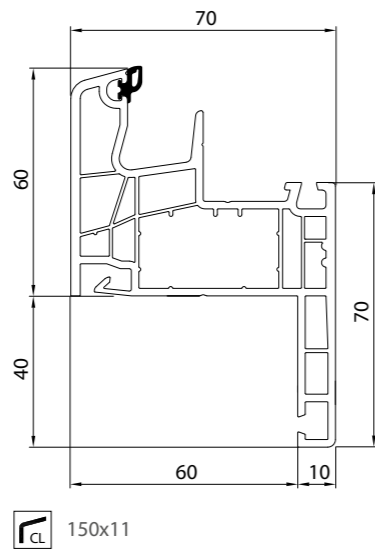
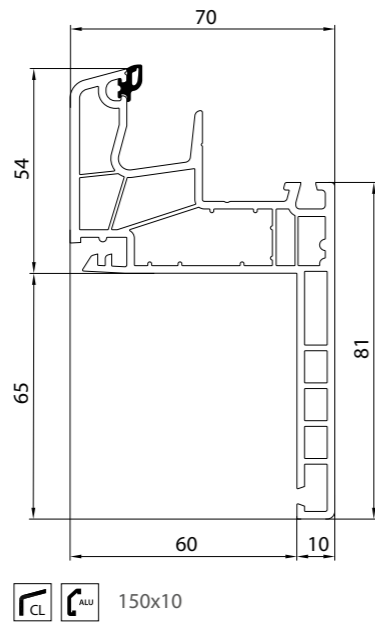
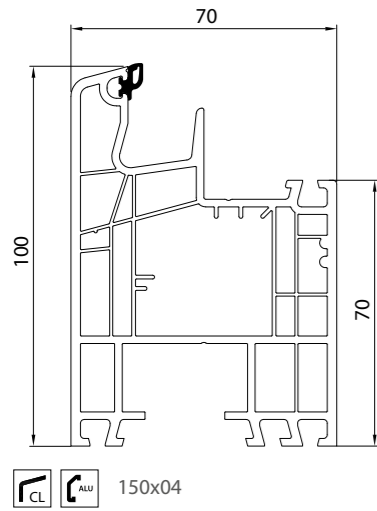
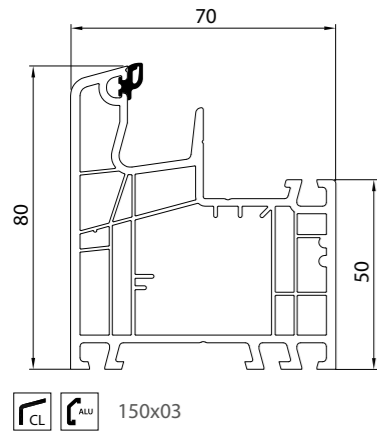
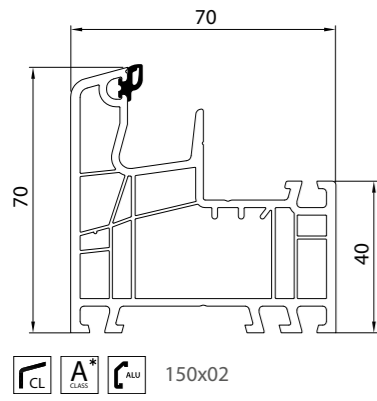

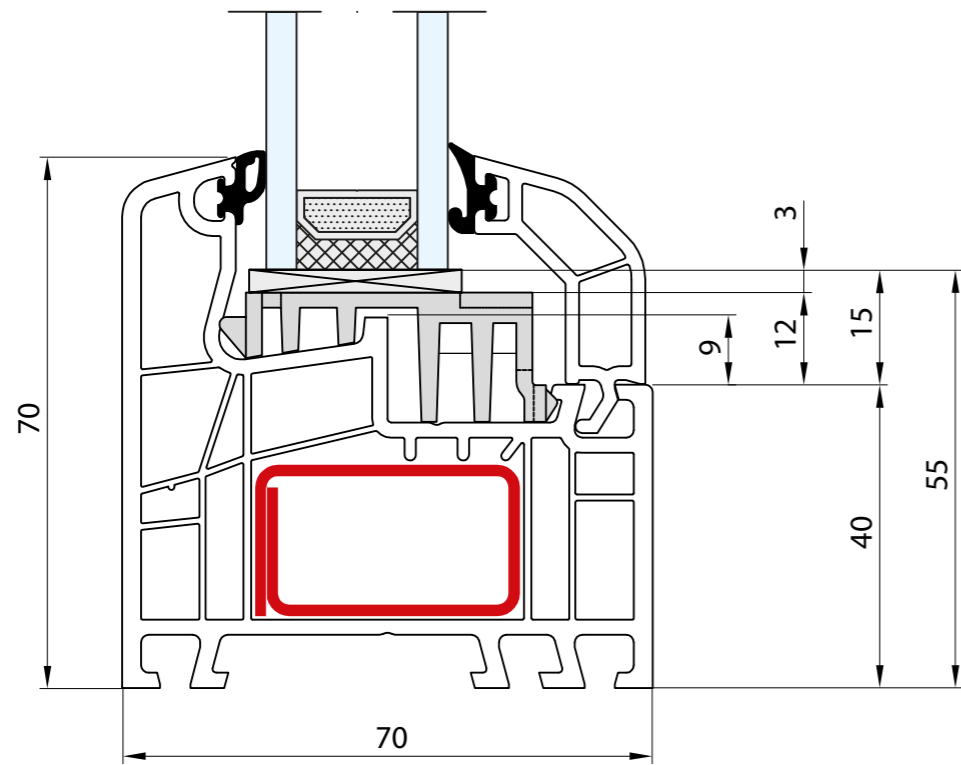
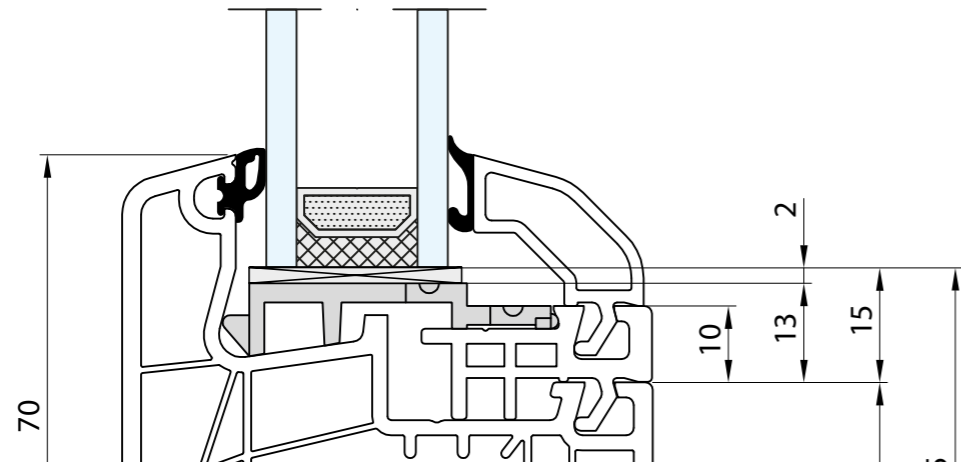

- Rama: 70 mm
- Dormant: 70 mm
- Frame: 70 mm
- Rahmen: 70 mm
- Telaio: 70 mm

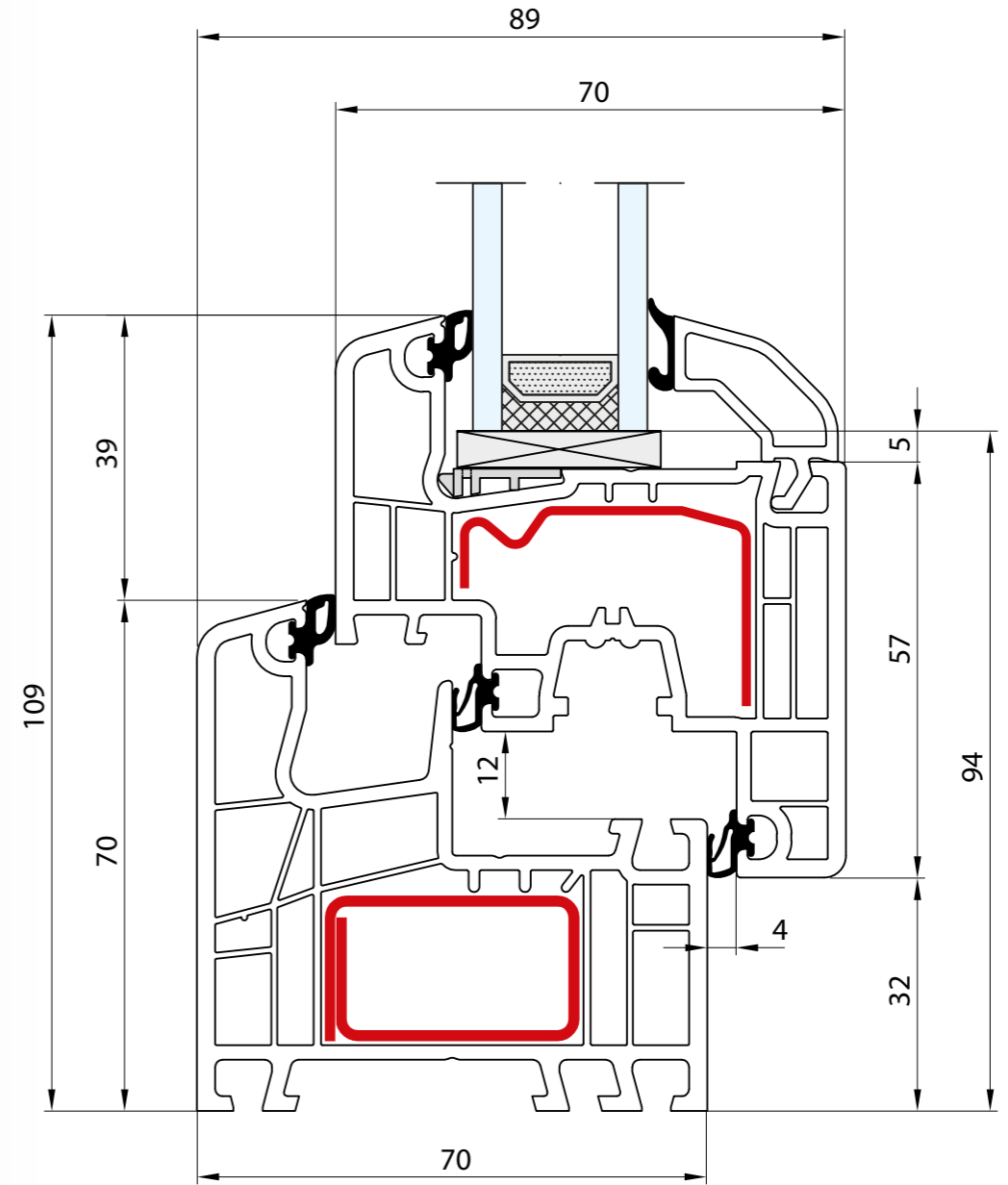
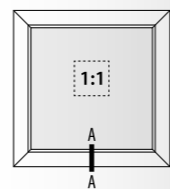

- Rama: 70 mm · Skrzydło: 77 mm
- Dormant: 70 mm · Vantail: 77 mm
- Frame: 70 mm · Sash: 77 mm
- Rahmen: 70 mm · Flügel: 77 mm
- Telaio: 70 mm · Anta: 77 mm

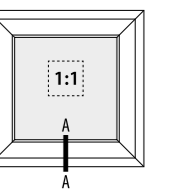

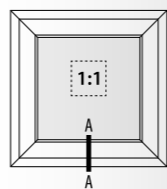
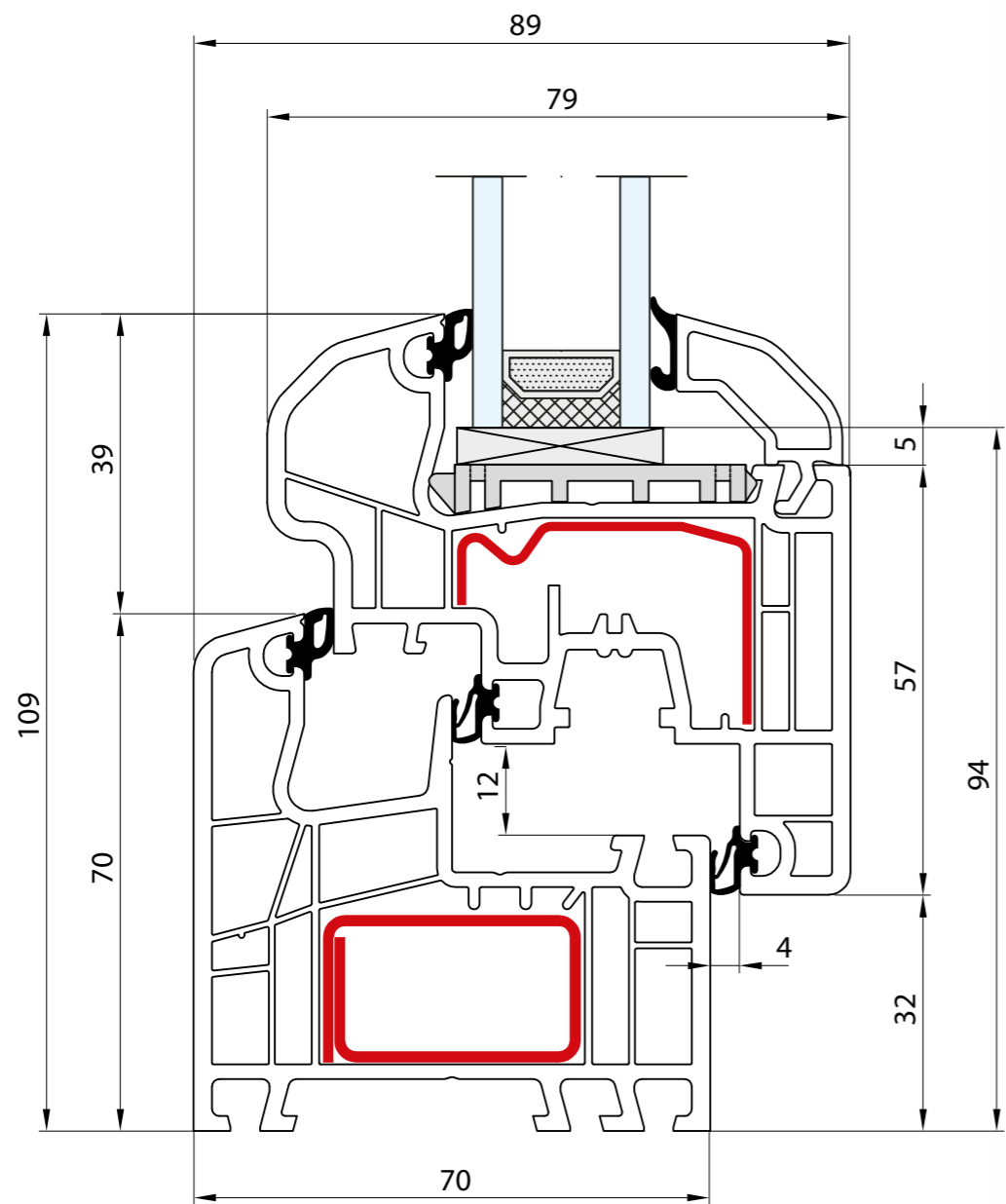

- Rama: 70 mm · Skrzydło: 77 mm
- Dormant: 70 mm · Vantail: 77 mm
- Frame: 70 mm · Sash: 77 mm
- Rahmen: 70 mm · Flügel: 77 mm
- Telaio: 70 mm · Anta: 77 mm

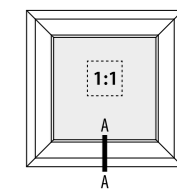
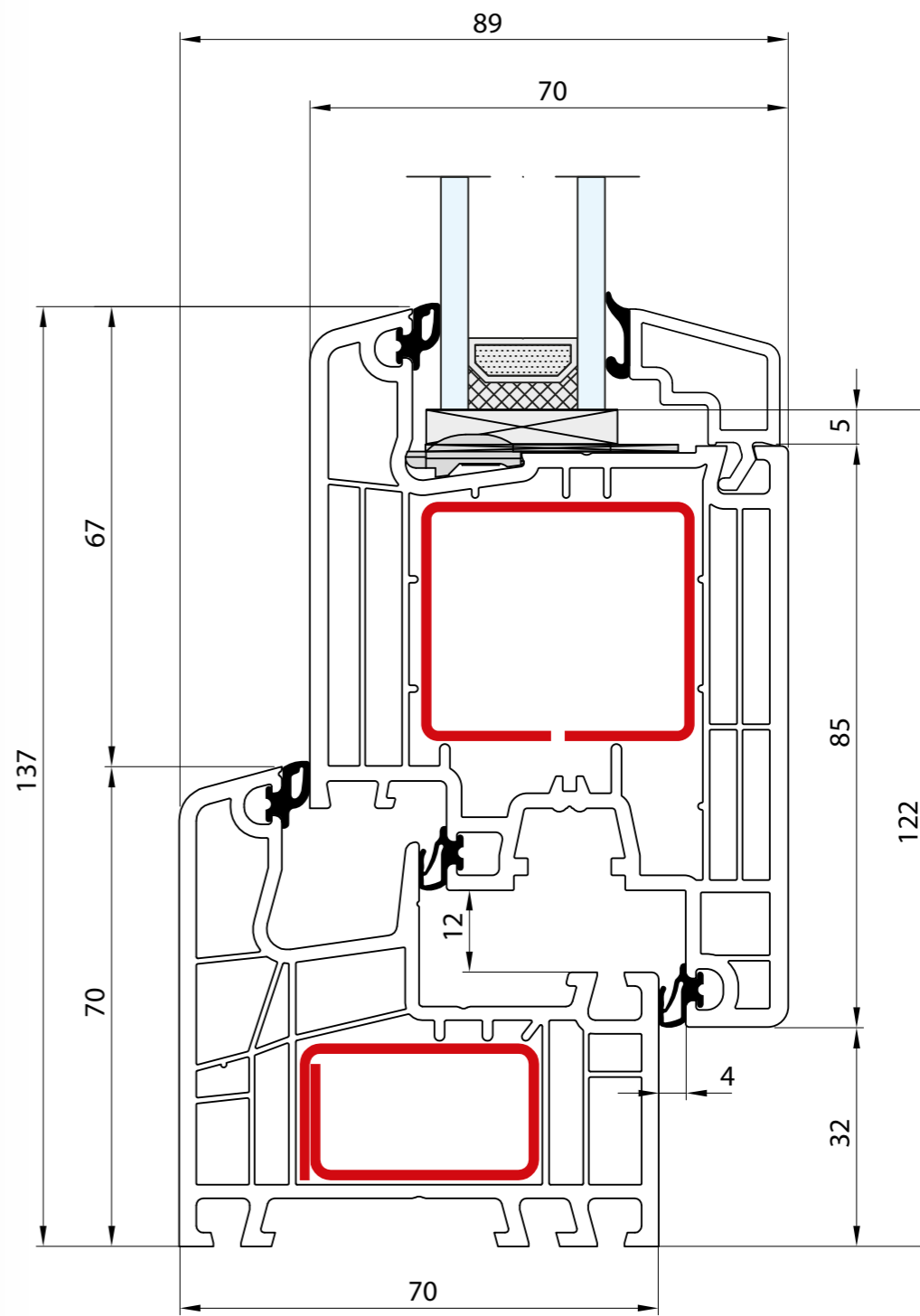

- Rama: 70 mm · Skrzydło: 105 mm
- Dormant: 70 mm · Vantail: 105 mm
- Frame: 70 mm · Sash: 105 mm
- Rahmen: 70 mm · Flügel: 105 mm
- Telaio: 70 mm · Anta: 105 mm

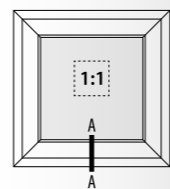
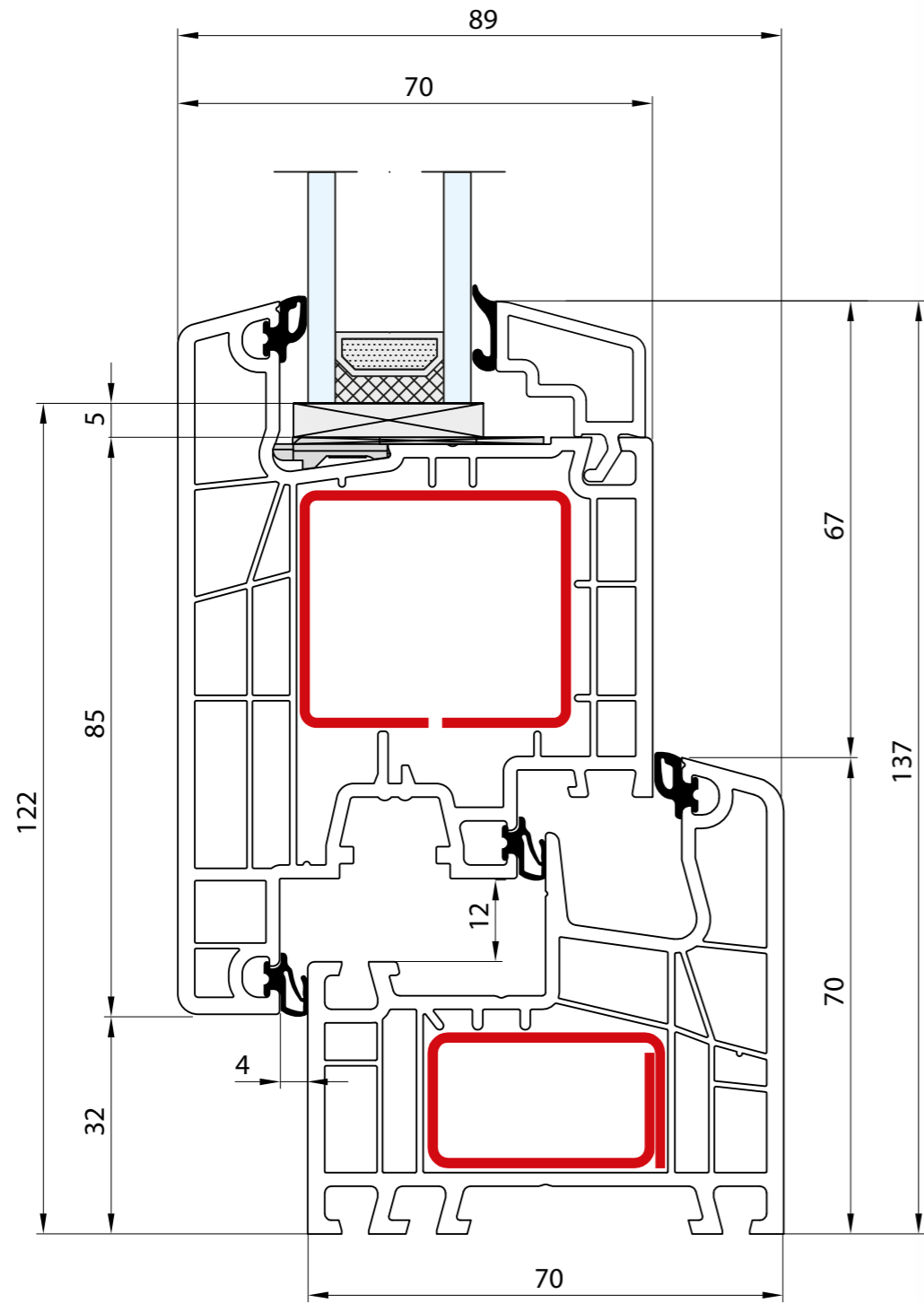

- Rama: 70 mm · Skrzydło: 105 mm
- Dormant: 70 mm · Vantail: 105 mm
- Frame: 70 mm · Sash: 105 mm
- Rahmen: 70 mm · Flügel: 105 mm
- Telaio: 70 mm · Anta: 105 mm

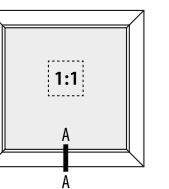
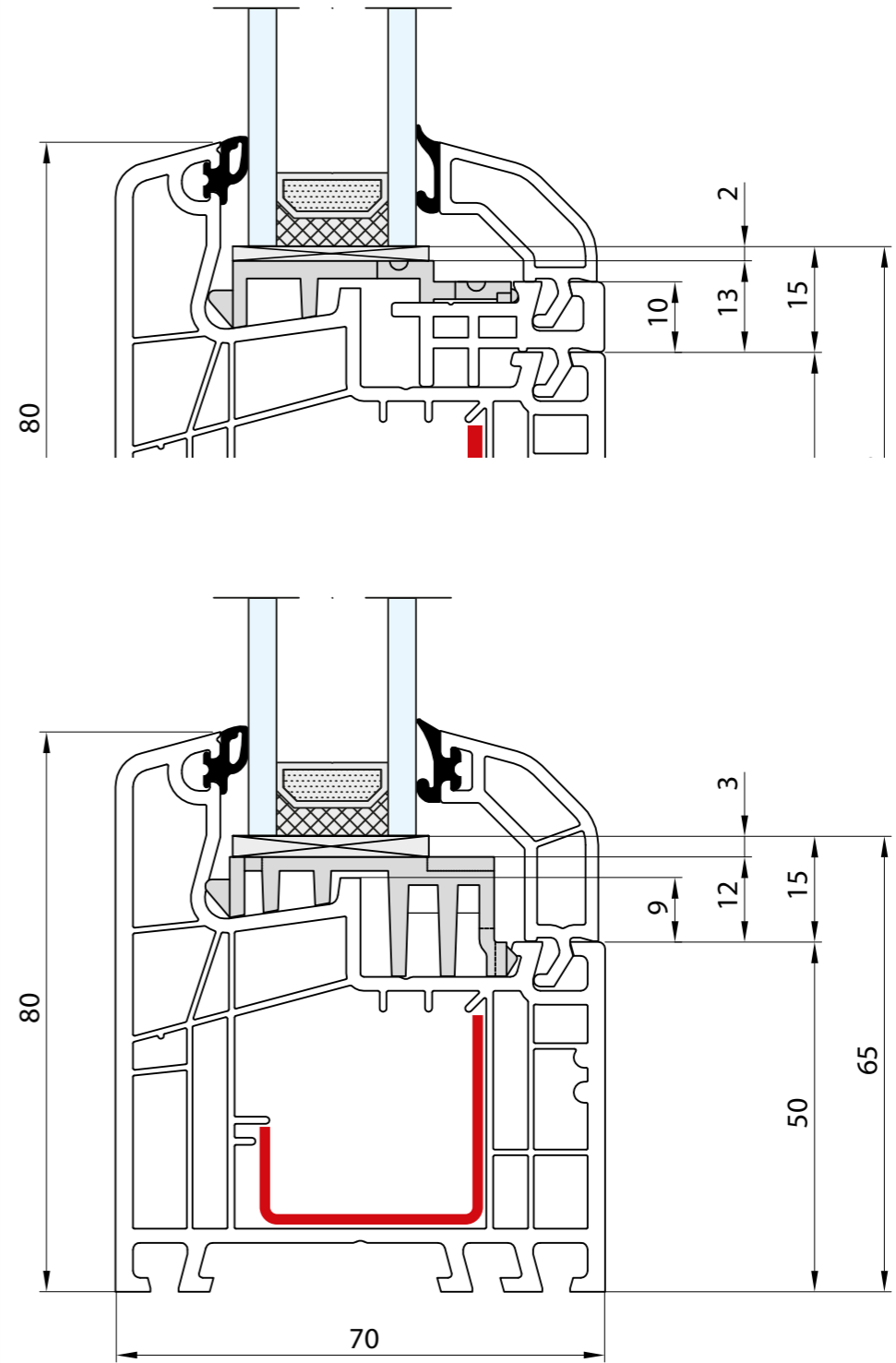

- Rama: 80 mm
- Dormant: 80 mm
- Frame: 80 mm
- Rahmen: 80 mm
- Telaio: 80 mm

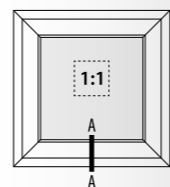
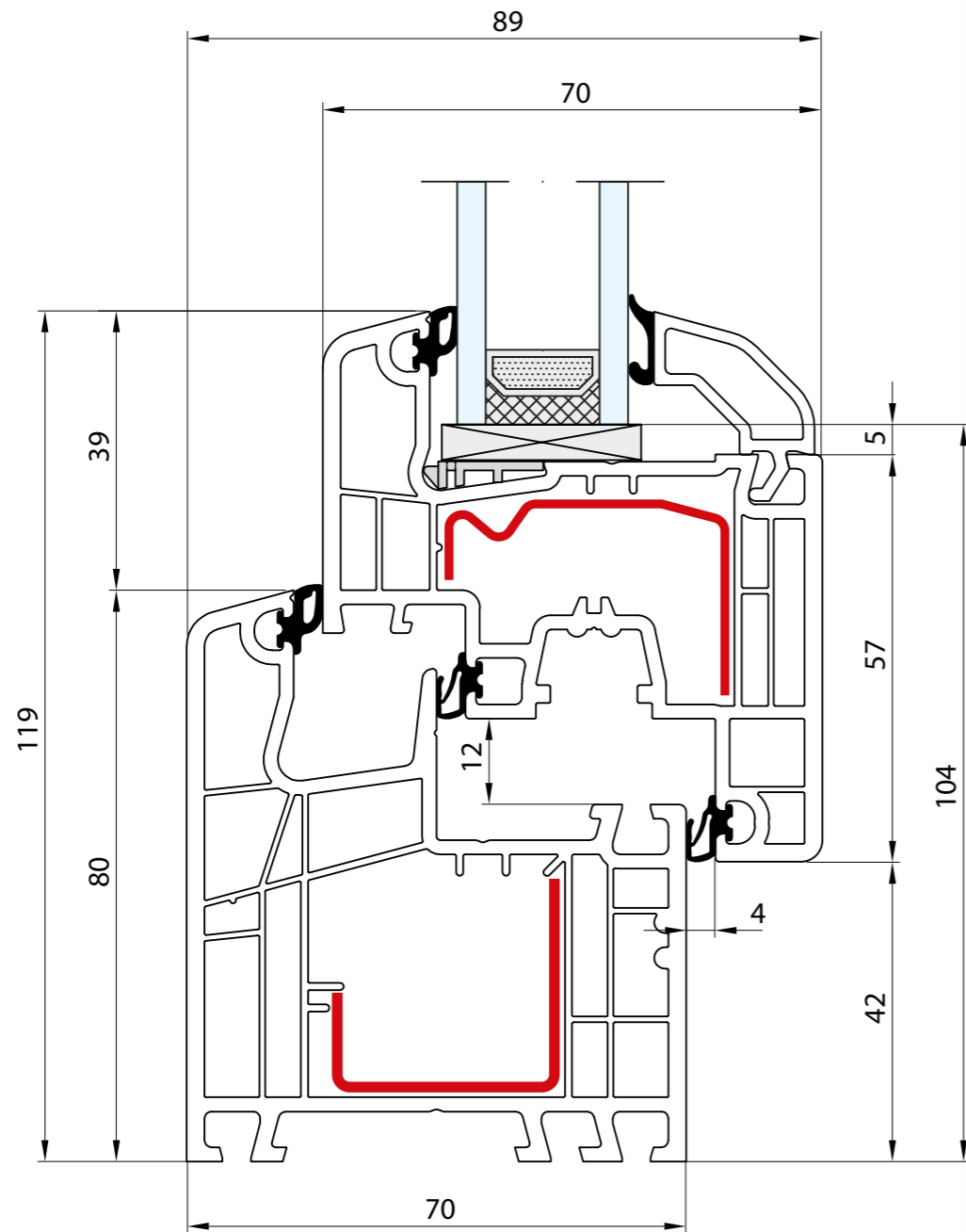

- Rama: 80 mm · Skrzydło: 77 mm
- Dormant: 80 mm · Vantail: 77 mm
- Frame: 80 mm · Sash: 77 mm
- Rahmen: 80 mm · Flügel: 77 mm
- Telaio: 80 mm · Anta: 77 mm

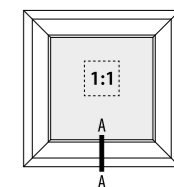
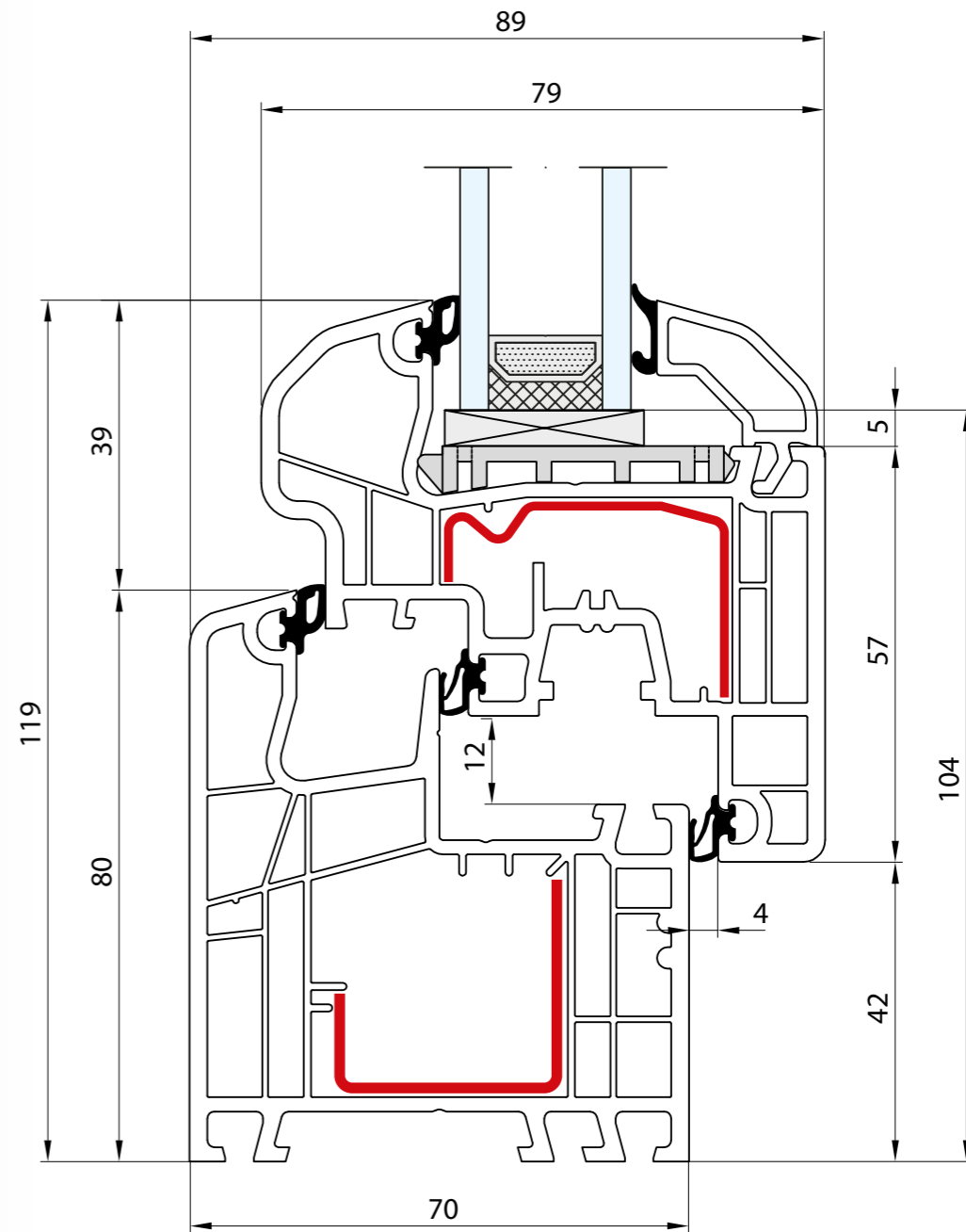

- Rama: 80 mm · Skrzydło: 77 mm
- Dormant: 80 mm · Vantail: 77 mm
- Frame: 80 mm · Sash: 77 mm
- Rahmen: 80 mm · Flügel: 77 mm
- Telaio: 80 mm · Anta: 77 mm

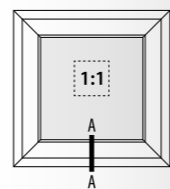
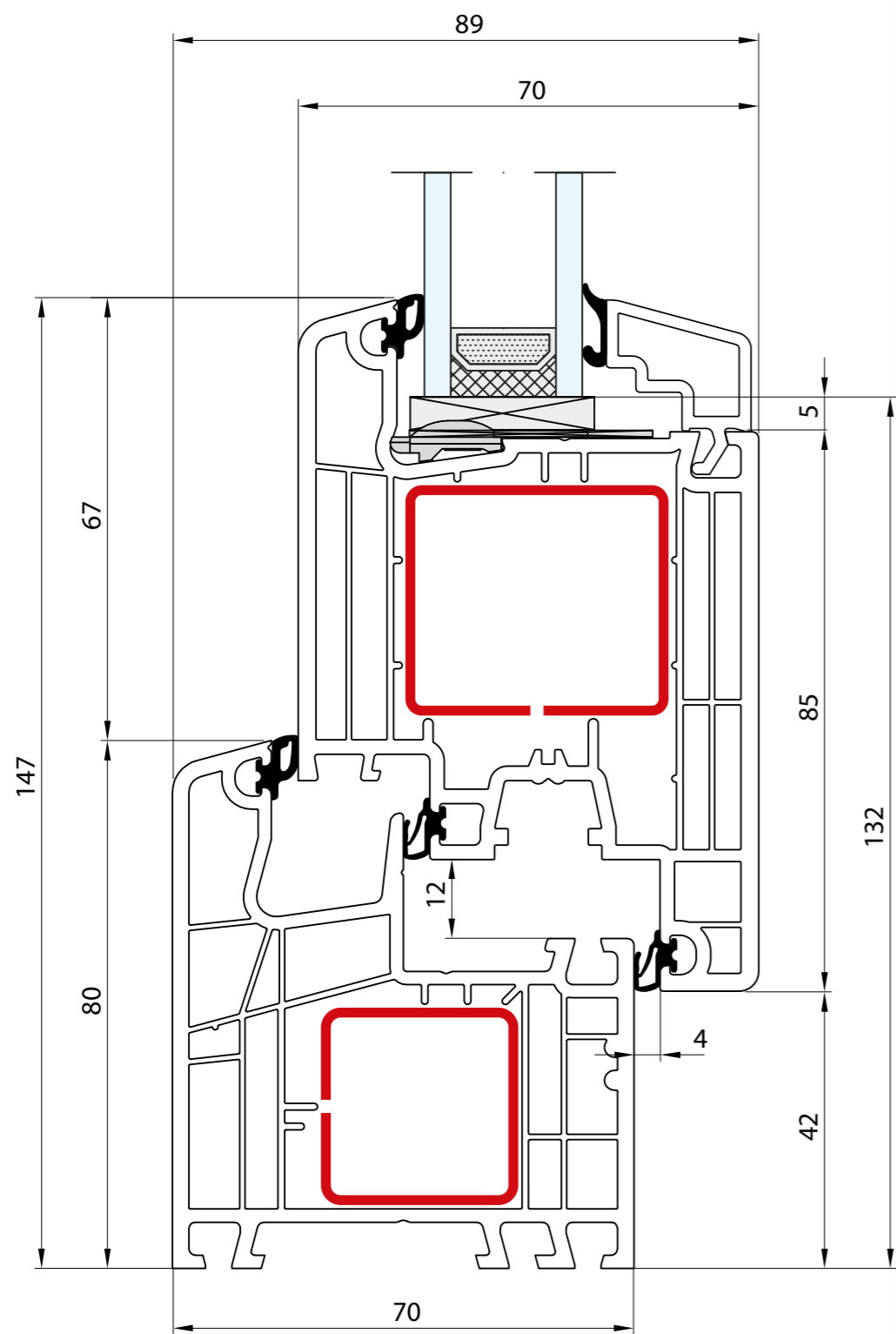

- Rama: 80 mm · Skrzydło: 105 mm
- Dormant: 80 mm · Vantail: 105 mm
- Frame: 80 mm · Sash: 105 mm
- Rahmen: 80 mm · Flügel: 105 mm
- Telaio: 80 mm · Anta: 105 mm

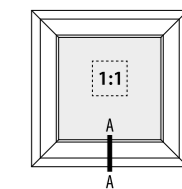
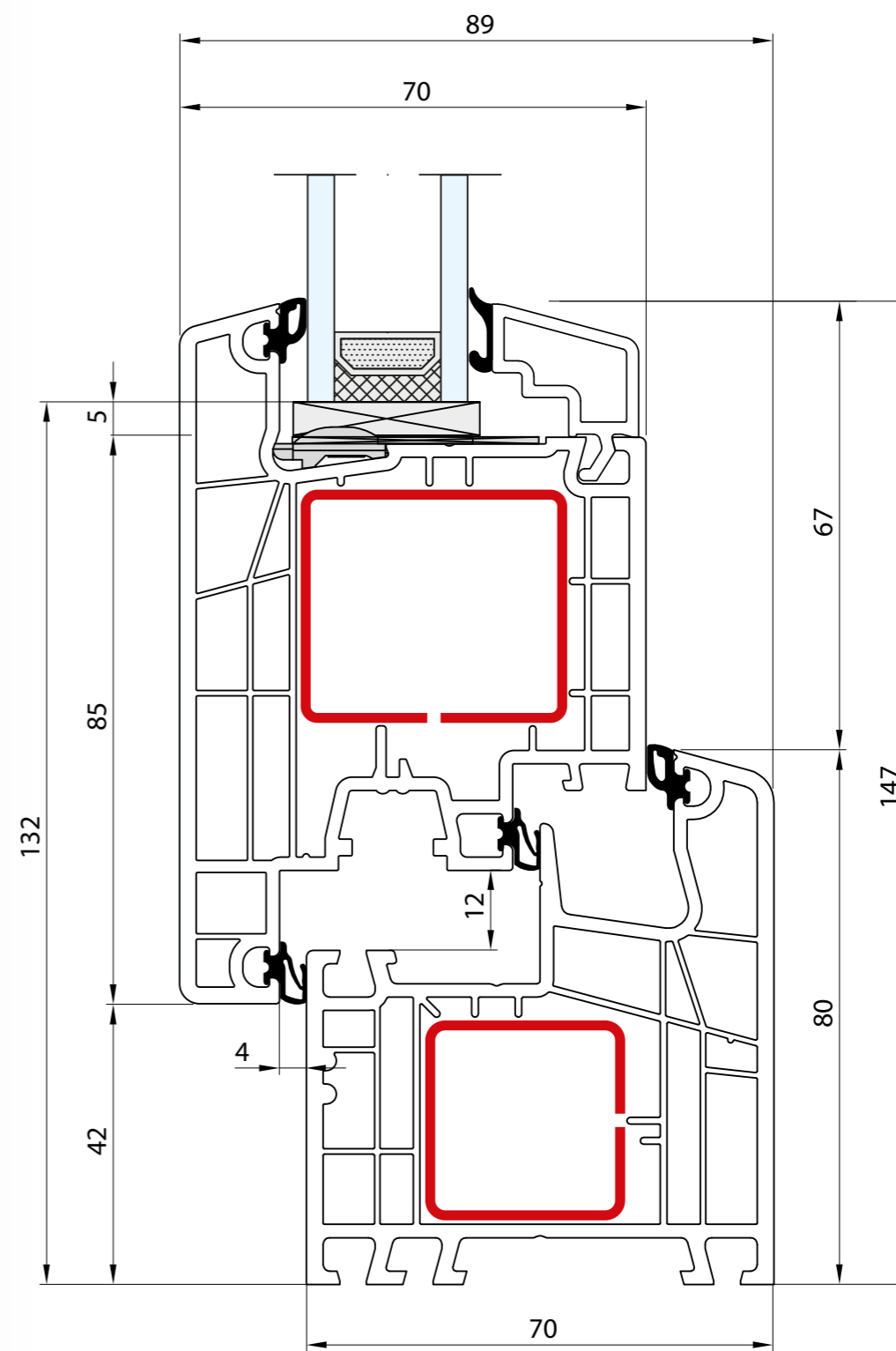

- Rama: 80 mm · Skrzydło: 105 mm
- Dormant: 80 mm · Vantail: 105 mm
- Frame: 80 mm · Sash: 105 mm
- Rahmen: 80 mm · Flügel: 105 mm
- Telaio: 80 mm · Anta: 105 mm

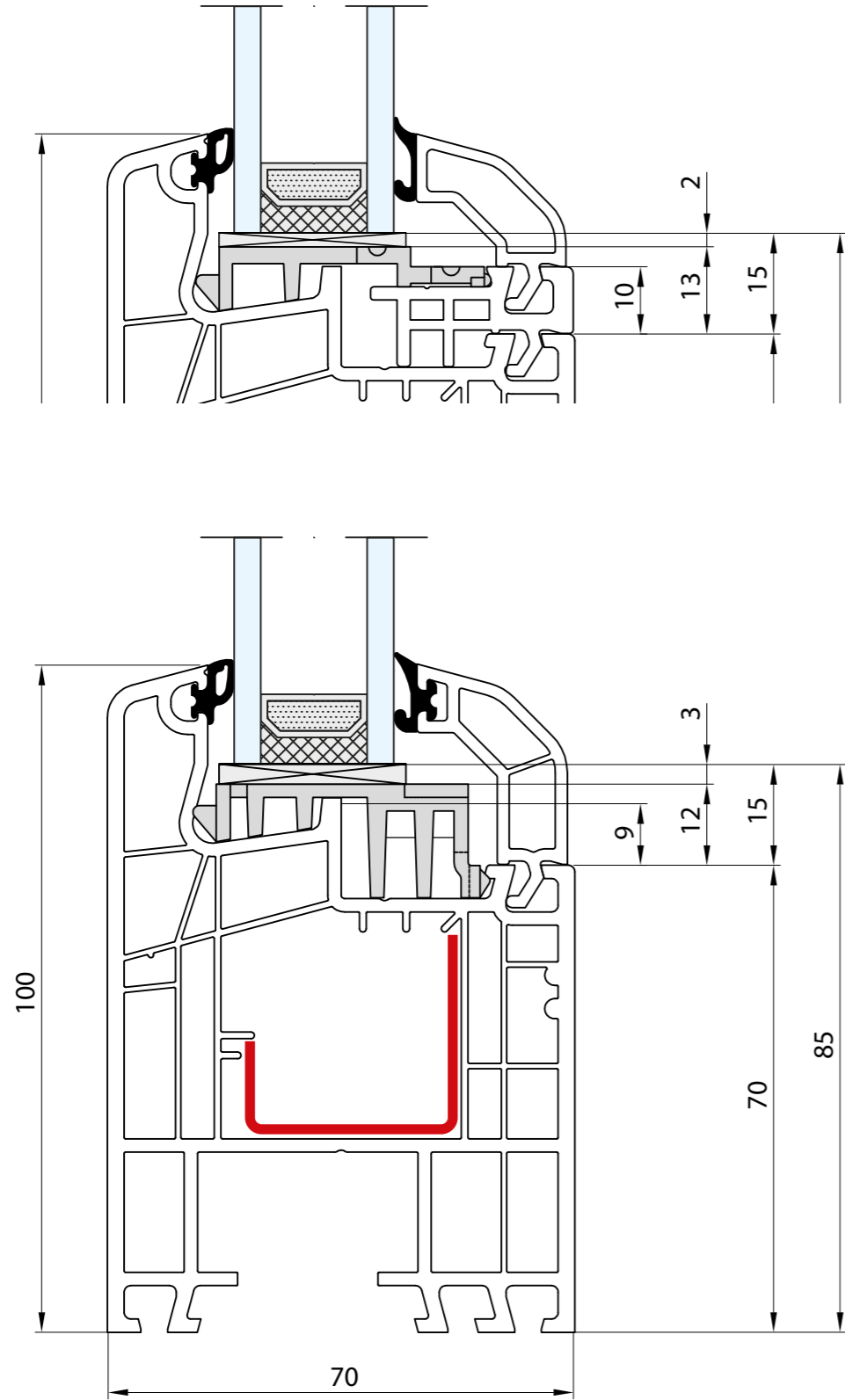

- Rama: 100 mm
- Dormant: 100 mm
- Frame: 100 mm
- Rahmen: 100 mm
- Telaio: 100 mm

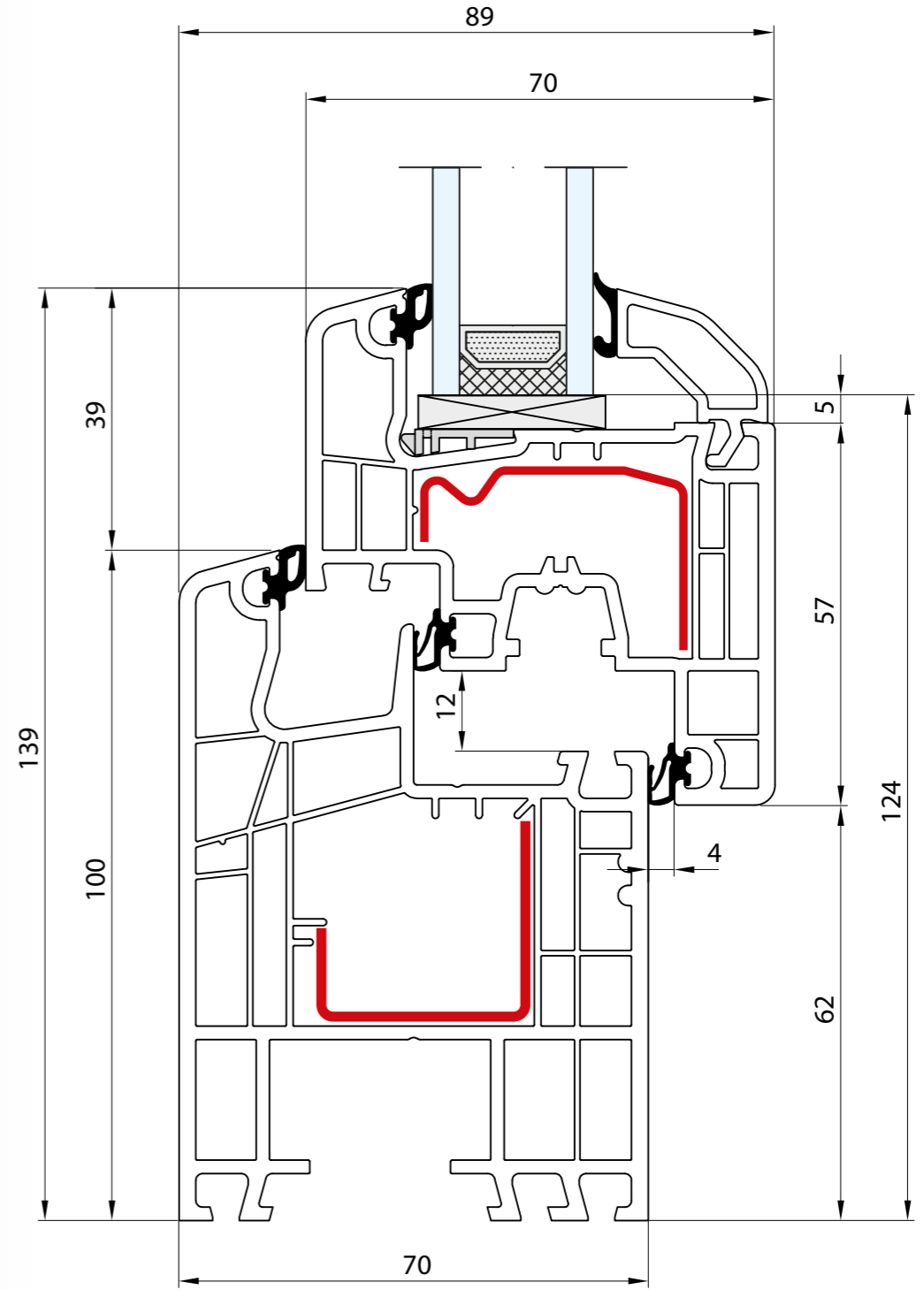
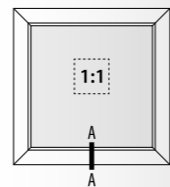

- Rama: 100 mm · Skrzydło: 77 mm
- Dormant: 100 mm · Vantail: 77 mm
- Frame: 100 mm · Sash: 77 mm
- Rahmen: 100 mm · Flügel: 77 mm
- Telaio: 100 mm · Anta: 77 mm

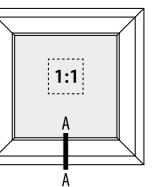

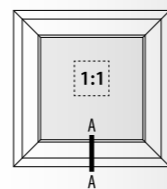
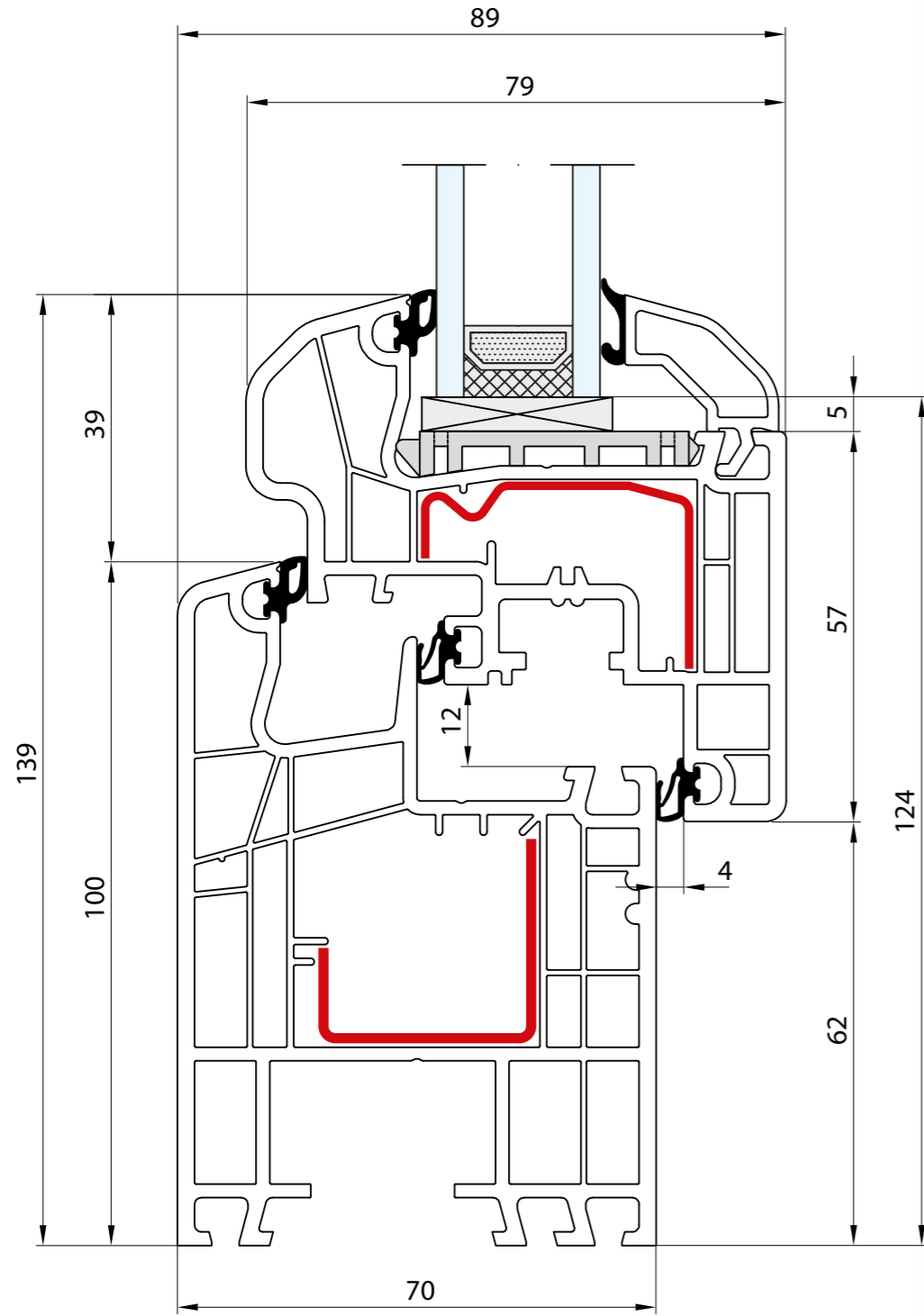

- Rama: 100 mm · Skrzydło: 77 mm
- Dormant: 100 mm · Vantail: 77 mm
- Frame: 100 mm · Sash: 77 mm
- Rahmen: 100 mm · Flügel: 77 mm
- Telaio: 100 mm · Anta: 77 mm

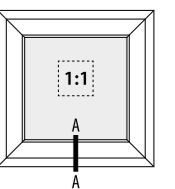
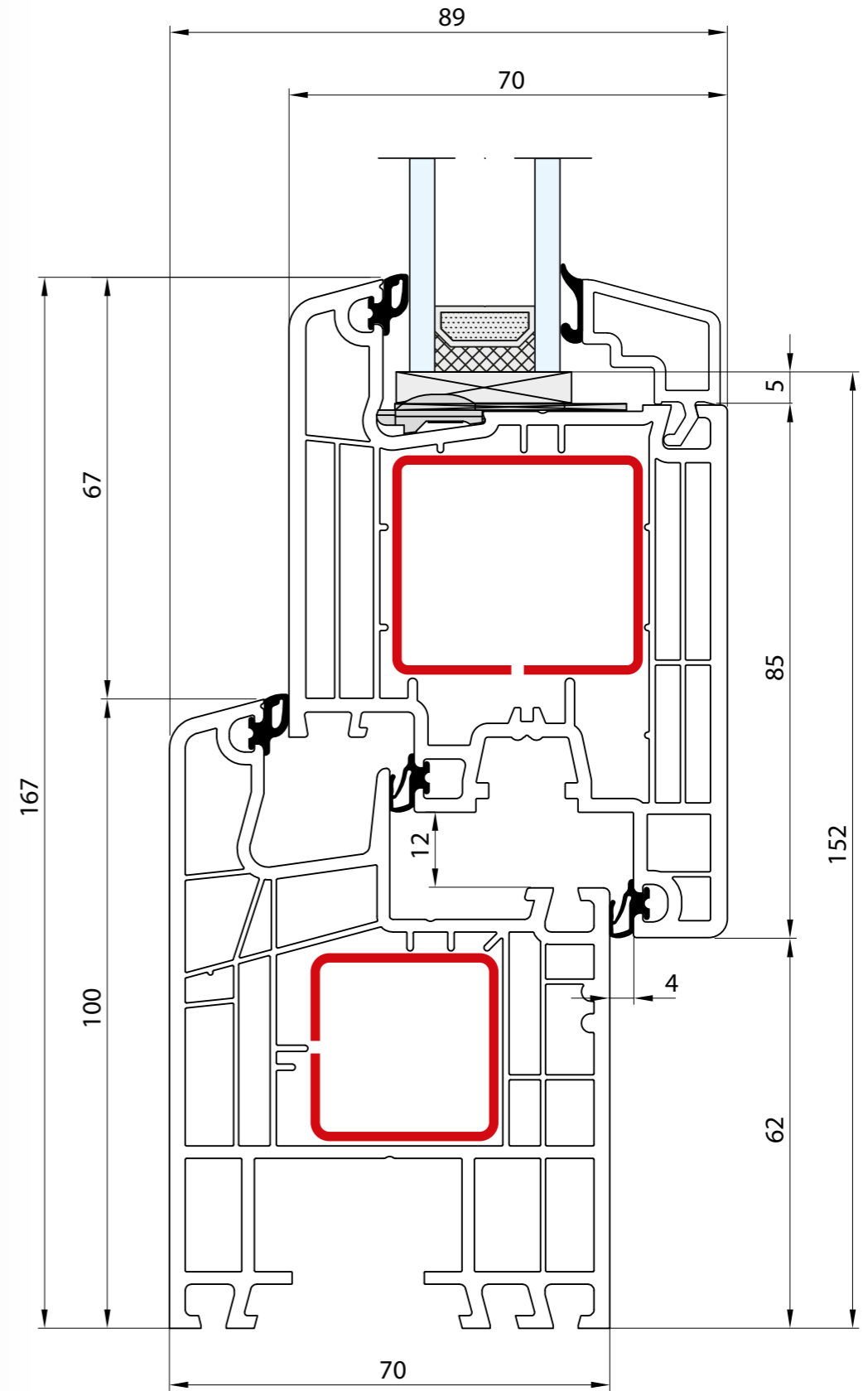

- Rama: 100 mm · Skrzydło: 105 mm
- Dormant: 100 mm · Vantail: 105 mm
- Frame: 100 mm · Sash: 105 mm
- Rahmen: 100 mm · Flügel: 105 mm
- Telaio: 100 mm · Anta: 105 mm

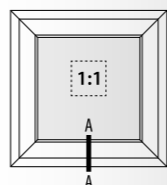
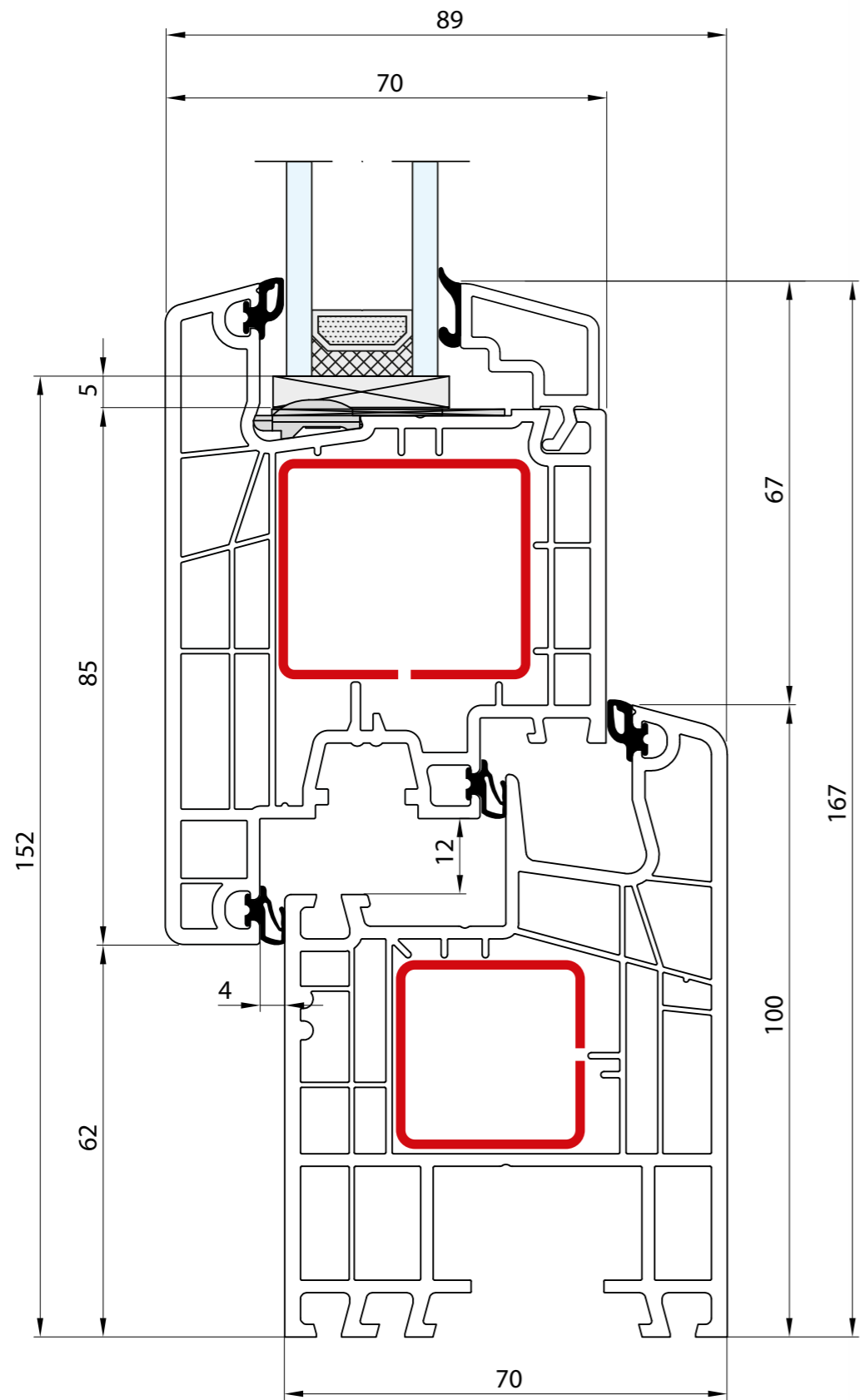

- Rama: 100 mm · Skrzydło: 105 mm
- Dormant: 100 mm · Vantail: 105 mm
- Frame: 100 mm · Sash: 105 mm
- Rahmen: 100 mm · Flügel: 105 mm
- Telaio: 100 mm · Anta: 105 mm

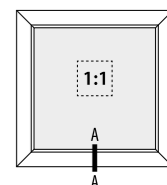
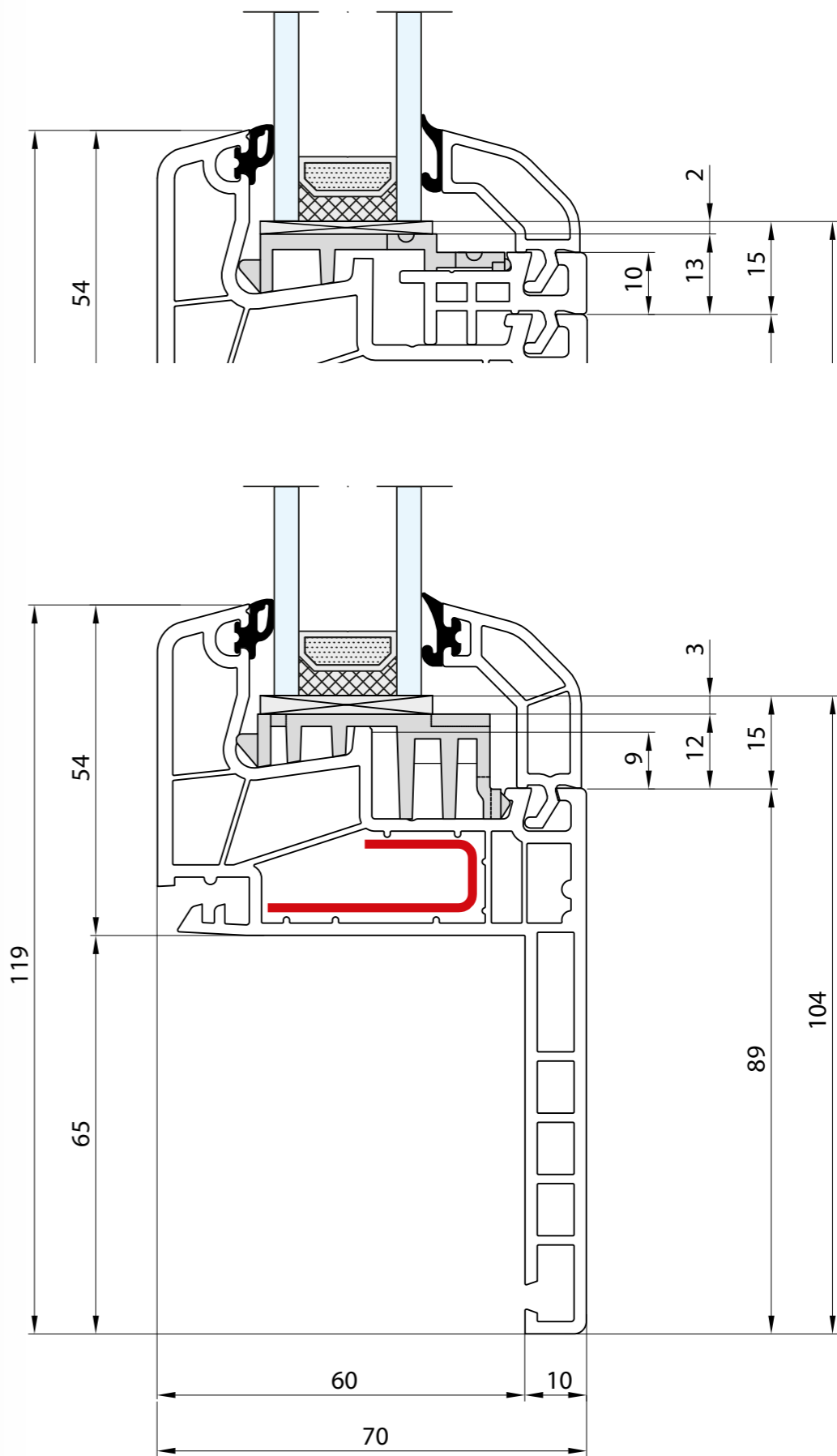

- RENOWACJA - Pletwa: 65 mm · Rama: 54 mm
- RÉNOVATION - Lip: 65 mm · Dormant: 54 mm
- RENOVATION - Strip: 65 mm · Frame: 54 mm
- RENOVIERUNG - Flosse: 65 mm · Rahmen: 54 mm
- RINNOVAZIONE - Aletta da: 65 mm · Telaio: 54 mm

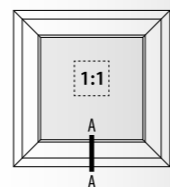
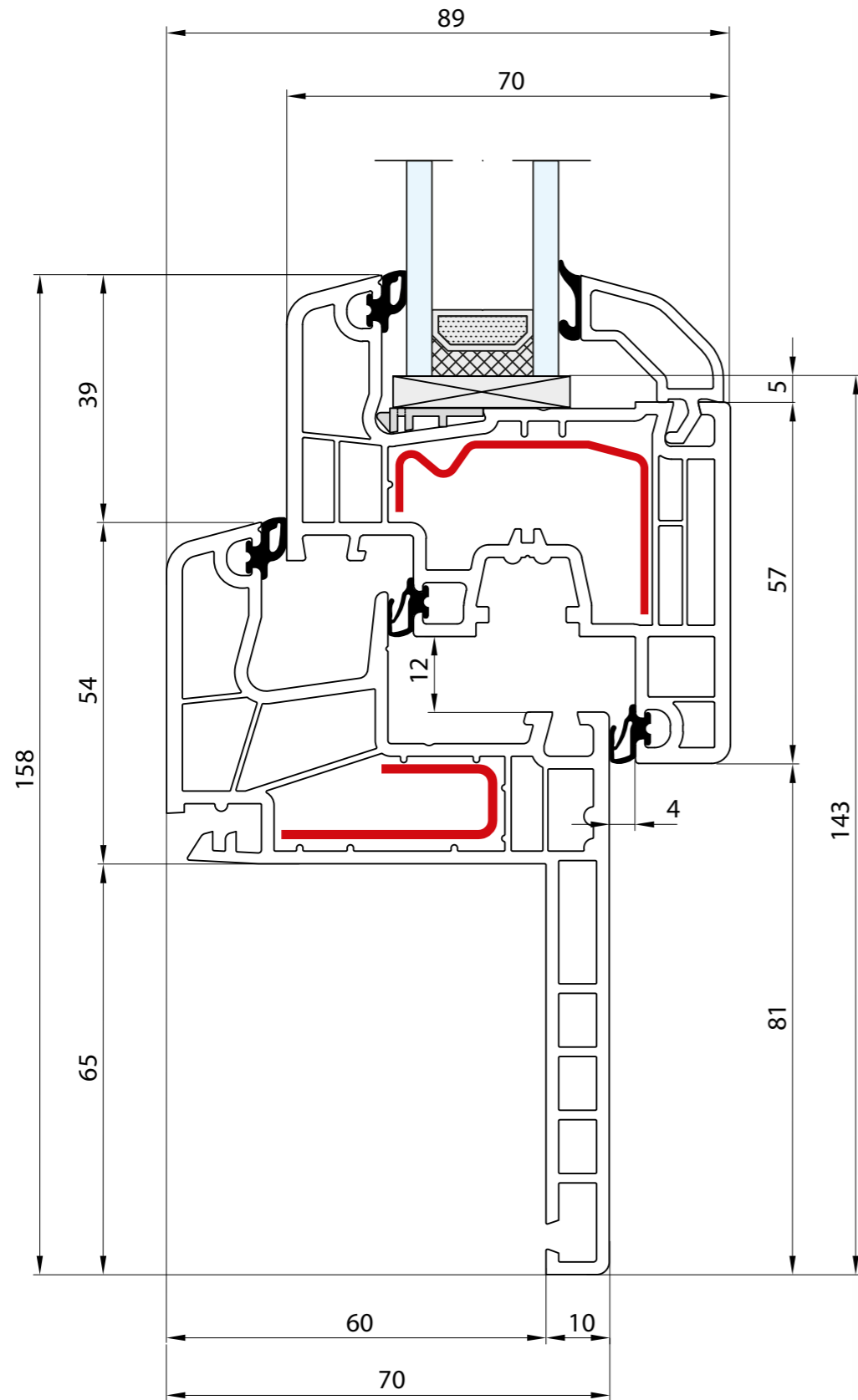

- RENOWACJA - Pletwa: 65 mm · Rama: 54 mm · Skrzydło: 77 mm
- RÉNOVATION - Lip: 65 mm · Dormant: 54 mm · Vantail: 77 mm
- RENOVATION - Strip: 65 mm · Frame: 54 mm · Sash: 77 mm
- RENOVIERUNG - Flosse: 65 mm · Rahmen: 54 mm · Flügel: 77 mm
- RINNOVAZIONE - Aletta da: 65 mm · Telaio: 54 mm · Anta: 77 mm

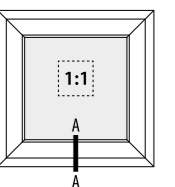
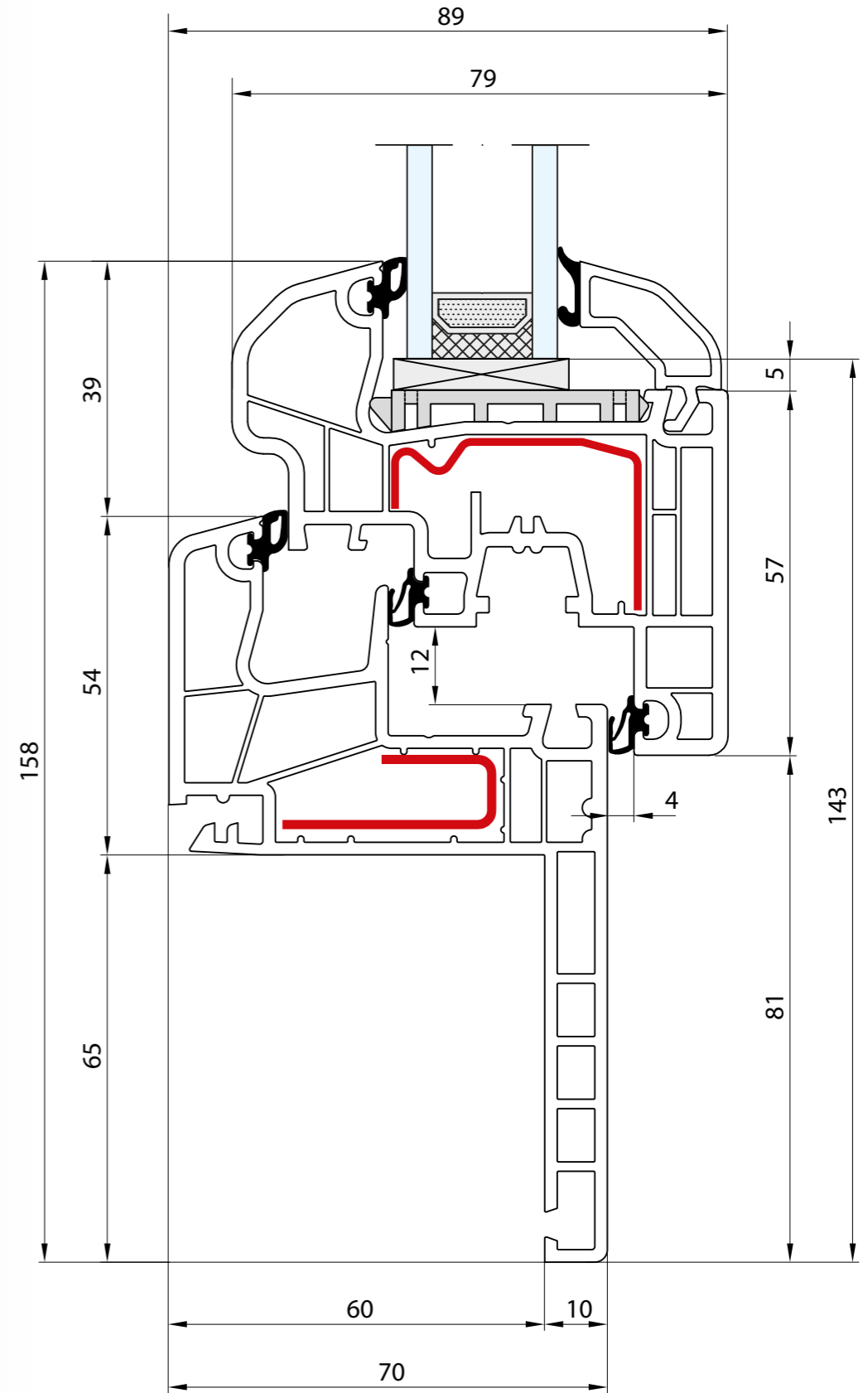

- RENOWACJA - Pletwa: 65 mm · Rama: 54 mm · Skrzydło: 77 mm
- RÉNOVATION - Lip: 65 mm · Dormant: 54 mm · Vantail: 77 mm
- RENOVATION - Strip: 65 mm · Frame: 54 mm · Sash: 77 mm
- RENOVIERUNG - Flosse: 65 mm · Rahmen: 54 mm · Flügel: 77 mm
- RINNOVAZIONE - Aletta da: 65 mm · Telaio: 54 mm · Anta: 77 mm

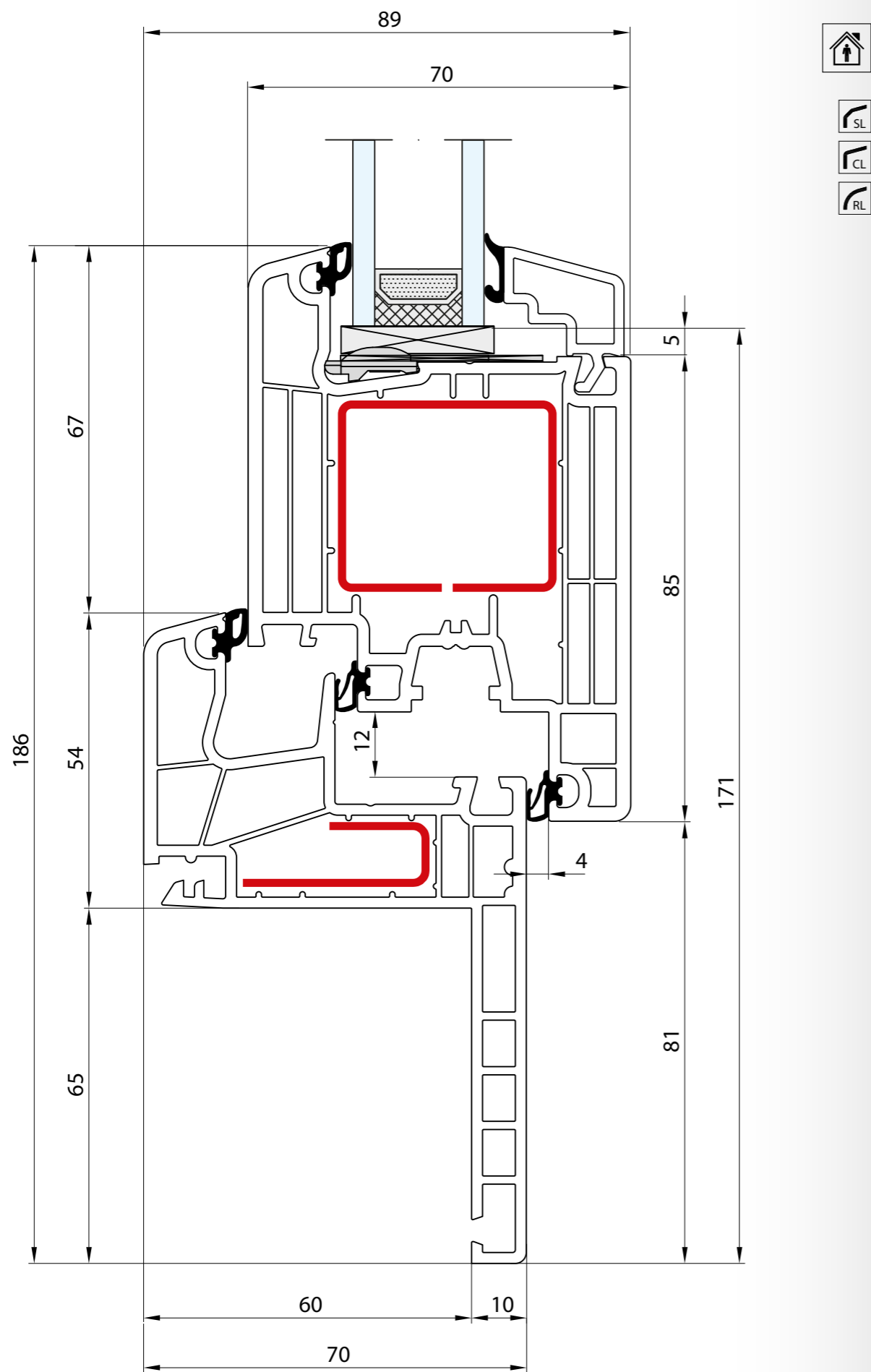

- RENOWACJA - Pletwa: 65 mm · Rama: 54 mm · Skrzydło: 105 mm
- RÉNOVATION - Lip: 65 mm · Dormant: 54 mm · Vantail: 105 mm
- RENOVATION - Strip: 65 mm · Frame: 54 mm · Sash: 105 mm
- RENOVIERUNG - Flosse: 65 mm · Rahmen: 54 mm · Flügel: 105 mm
- RINNOVAZIONE - Aletta da: 65 mm · Telaio: 54 mm · Anta: 105 mm

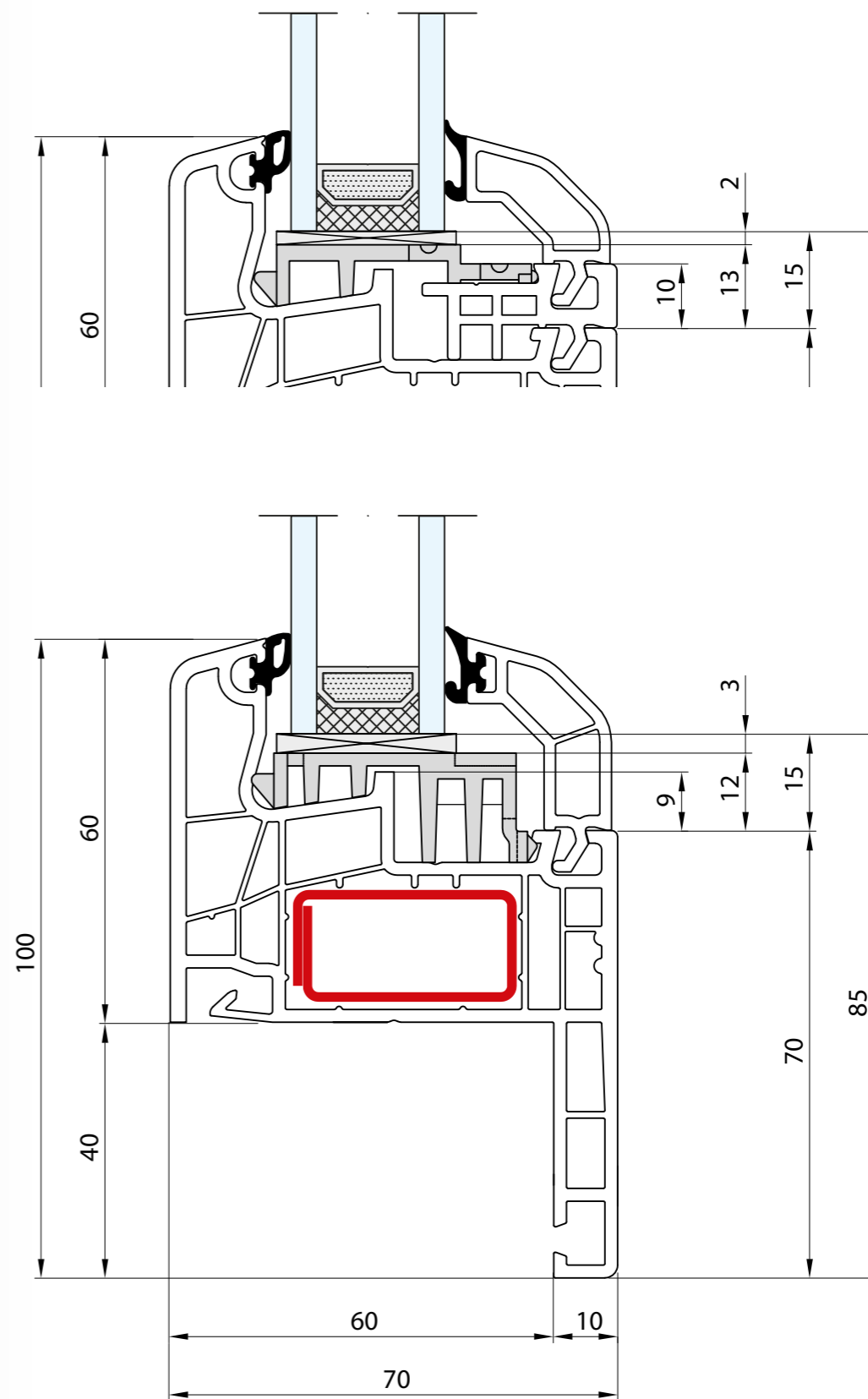
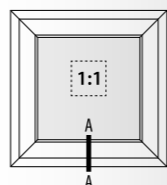

- RENOWACJA - Pletwa: 40 mm · Rama: 60 mm
- RÉNOVATION - Lip: 40 mm · Dormant: 60 mm
- RENOVATION - Strip: 40 mm · Frame: 60 mm
- RENOVIERUNG - Flosse: 40 mm · Rahmen: 60 mm
- RINNOVAZIONE - Aletta da: 40 mm · Telaio: 60 mm

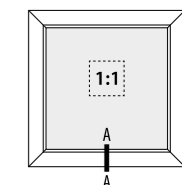

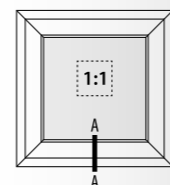
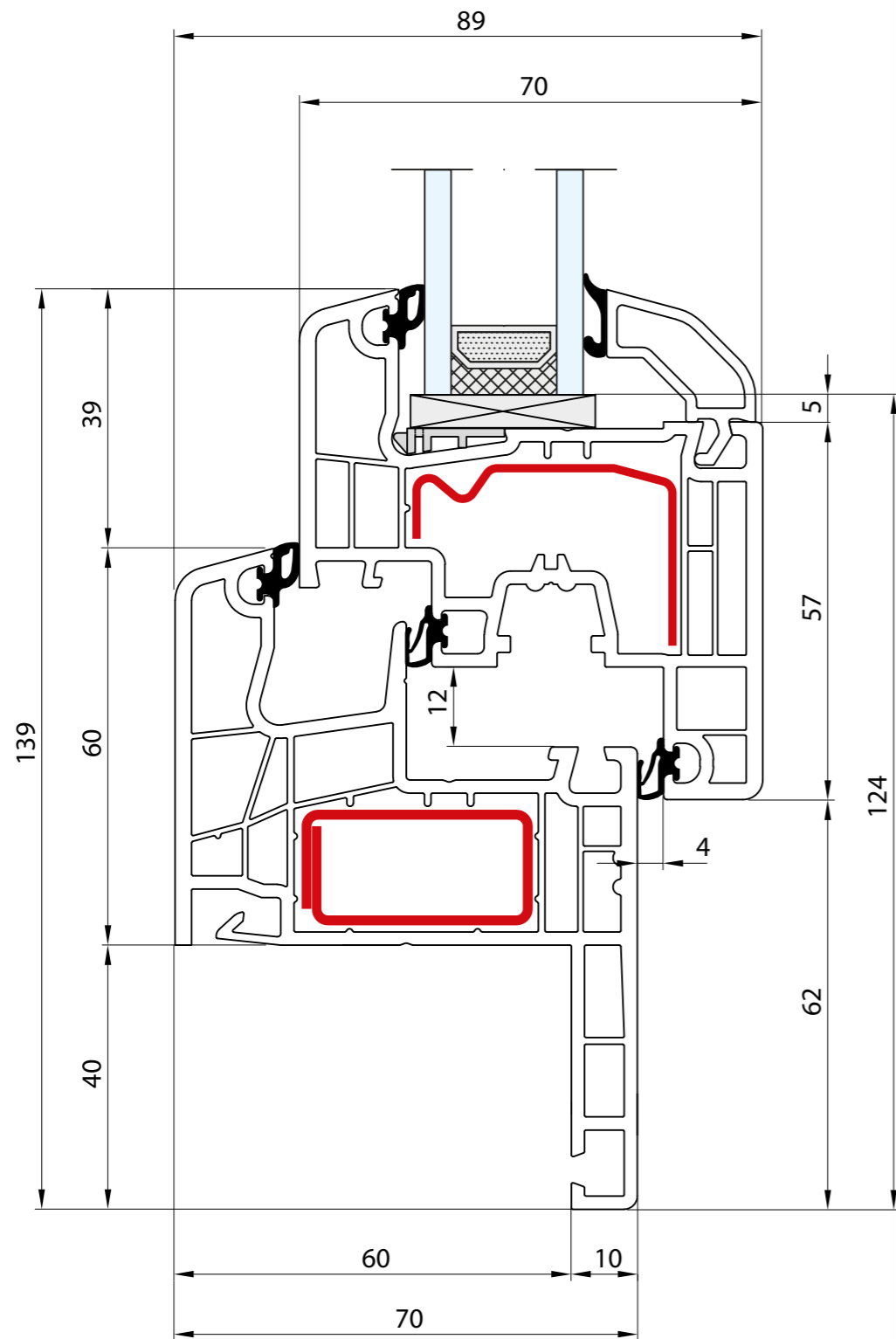

- RENOWACJA - Pletwa: 40 mm · Rama: 60 mm · Skrzydło: 77 mm
- RÉNOVATION - Lip: 40 mm · Dormant: 60 mm · Vantail: 77 mm
- RENOVATION - Strip: 40 mm · Frame: 60 mm · Sash: 77 mm
- RENOVIERUNG - Flosse: 40 mm · Rahmen: 60 mm · Flügel: 77 mm
- RINNOVAZIONE - Aletta da: 40 mm · Telaio: 60 mm · Anta: 77 mm

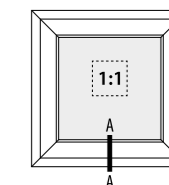
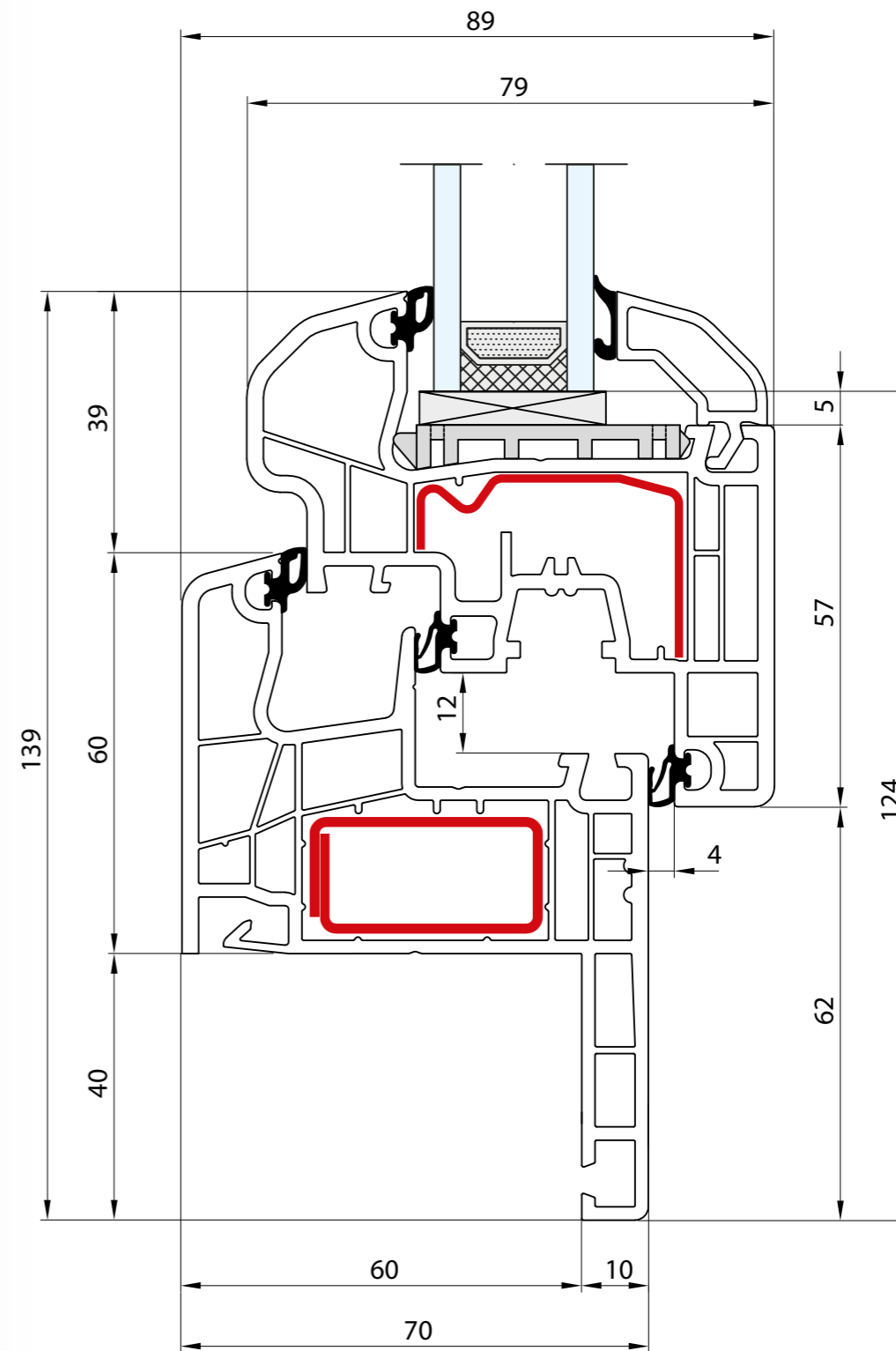

- RENOWACJA - Pletwa: 40 mm · Rama: 60 mm · Skrzydło: 77 mm
- RÉNOVATION - Lip: 40 mm · Dormant: 60 mm · Vantail: 77 mm
- RENOVATION - Strip: 40 mm · Frame: 60 mm · Sash: 77 mm
- RENOVIERUNG - Flosse: 40 mm · Rahmen: 60 mm · Flügel: 77 mm
- RINNOVAZIONE - Aletta da: 40 mm · Telaio: 60 mm · Anta: 77 mm

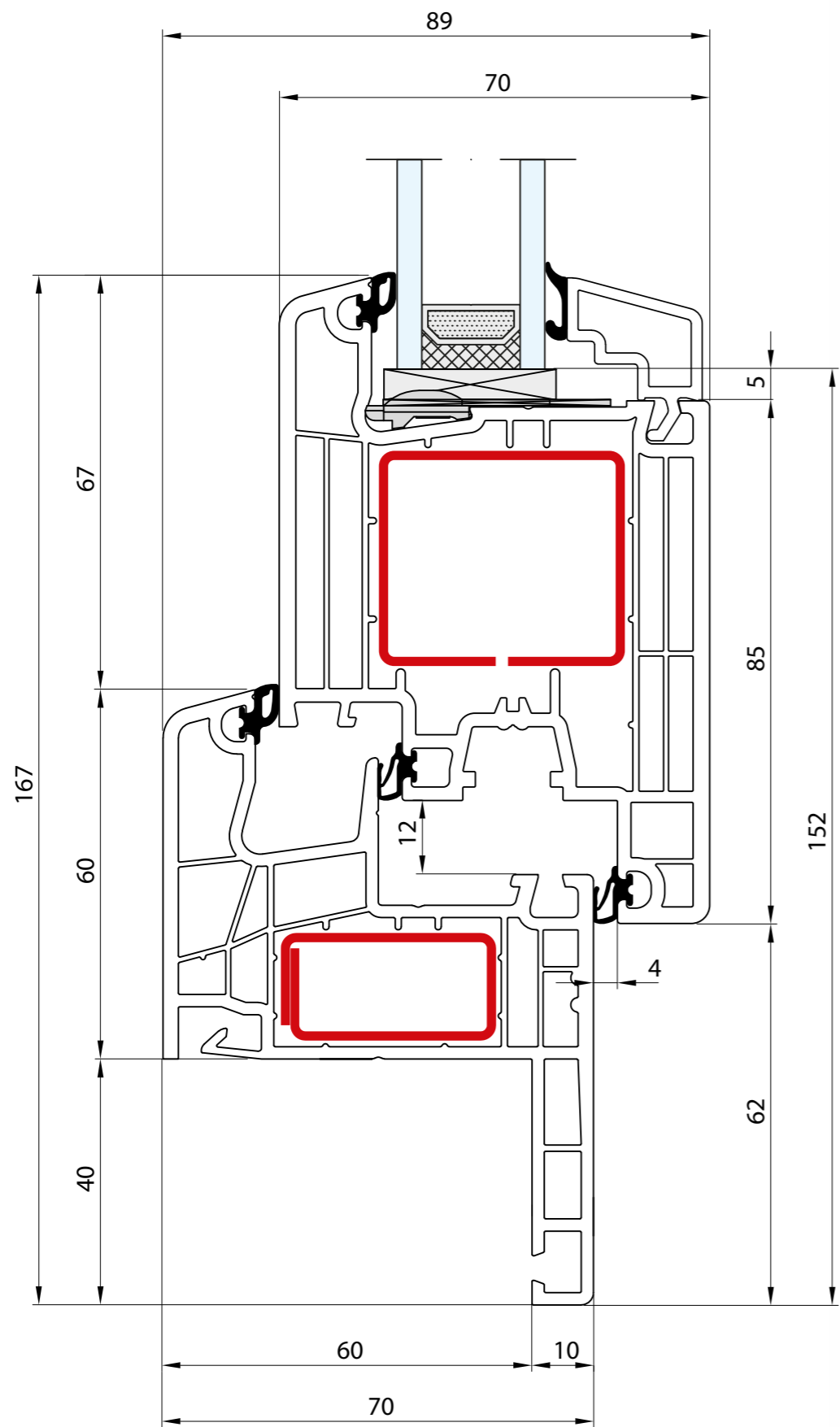

- RENOWACJA - Pletwa: 40 mm · Rama: 60 mm · Skrzydło: 105 mm
- RÉNOVATION - Lip: 40 mm · Dormant: 60 mm · Vantail: 105 mm
- RENOVATION - Strip: 40 mm · Frame: 60 mm · Sash: 105 mm
- RENOVIERUNG - Flosse: 40 mm · Rahmen: 60 mm · Flügel: 105 mm
- RINNOVAZIONE - Aletta da: 40 mm · Telaio: 60 mm · Anta: 105 mm

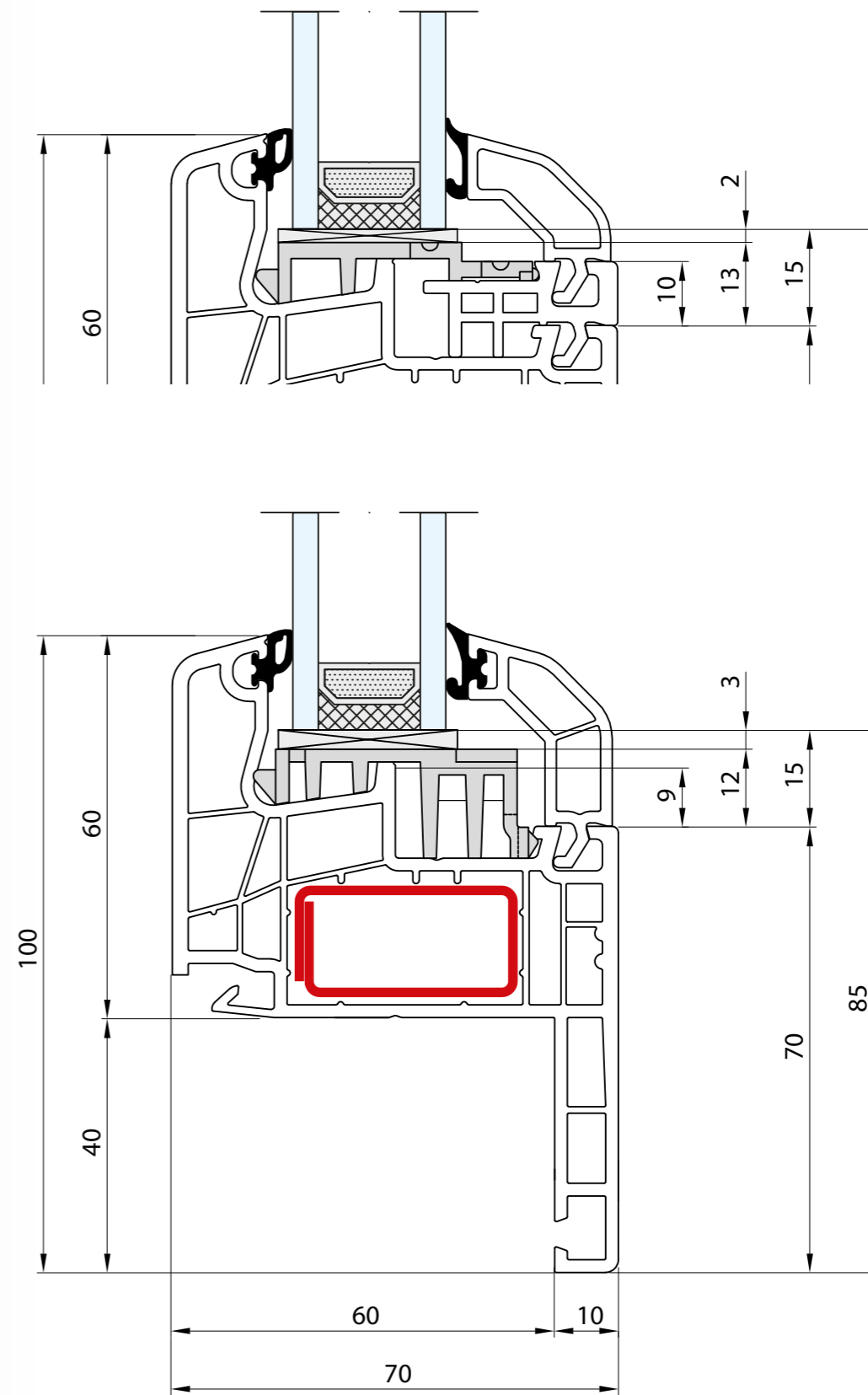
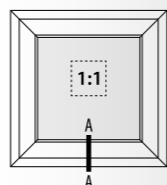

- RENOWACJA - Pletwa: 40 mm · Rama: 60 mm
- RÉNOVATION - Lip: 40 mm · Dormant: 60 mm
- RENOVATION - Strip: 40 mm · Frame: 60 mm
- RENOVIERUNG - Flosse: 40 mm · Rahmen: 60 mm
- RINNOVAZIONE - Aletta da: 40 mm · Telaio: 60 mm

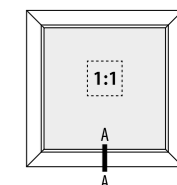

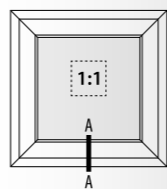
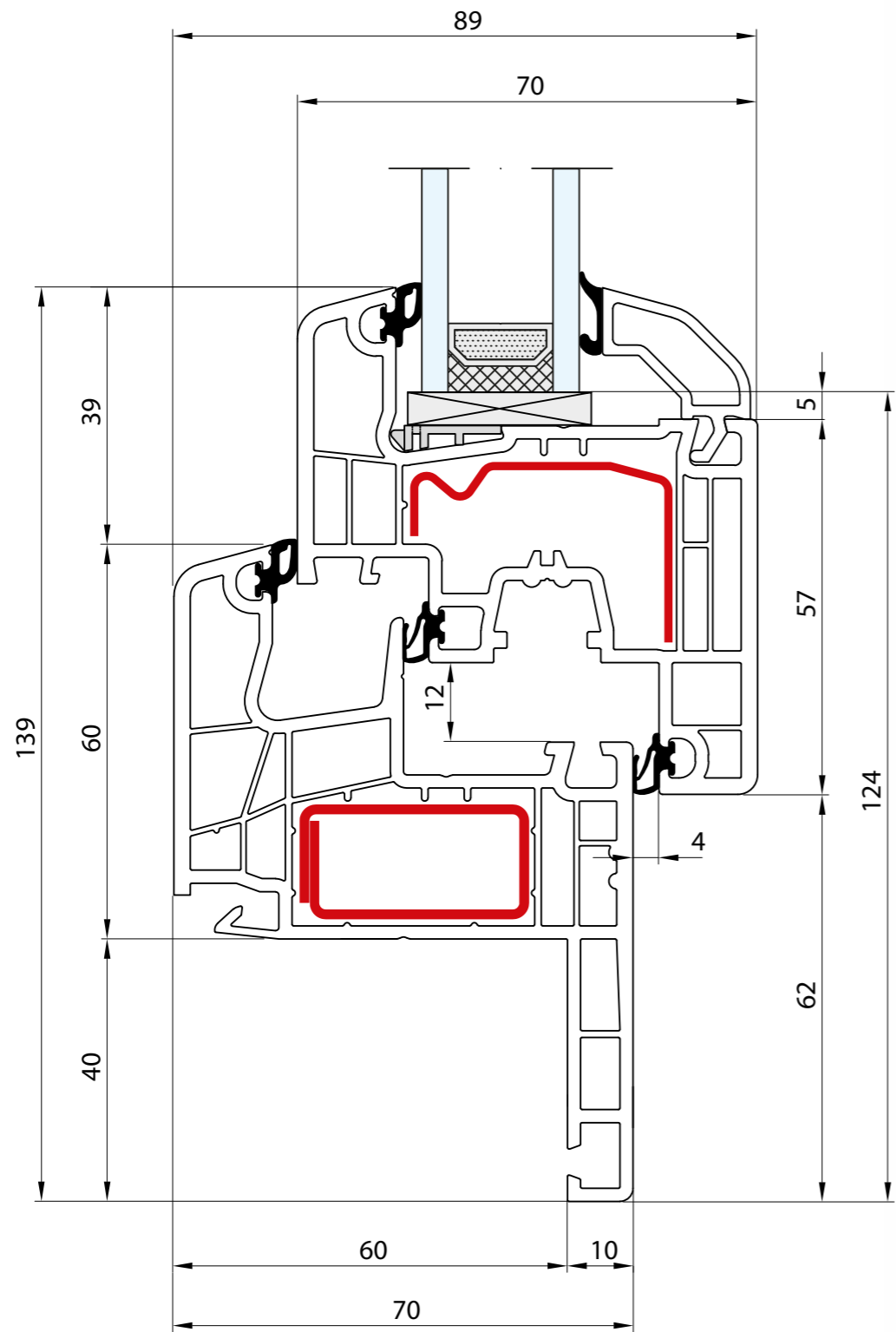

- RENOWACJA - Pletwa: 40 mm · Rama: 60 mm · Skrzydło: 77 mm
- RÉNOVATION - Lip: 40 mm · Dormant: 60 mm · Vantail: 77 mm
- RENOVATION - Strip: 40 mm · Frame: 60 mm · Sash: 77 mm
- RENOVIERUNG - Flosse: 40 mm · Rahmen: 60 mm · Flügel: 77 mm
- RINNOVAZIONE - Aletta da: 40 mm · Telaio: 60 mm · Anta: 77 mm

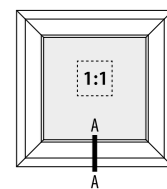
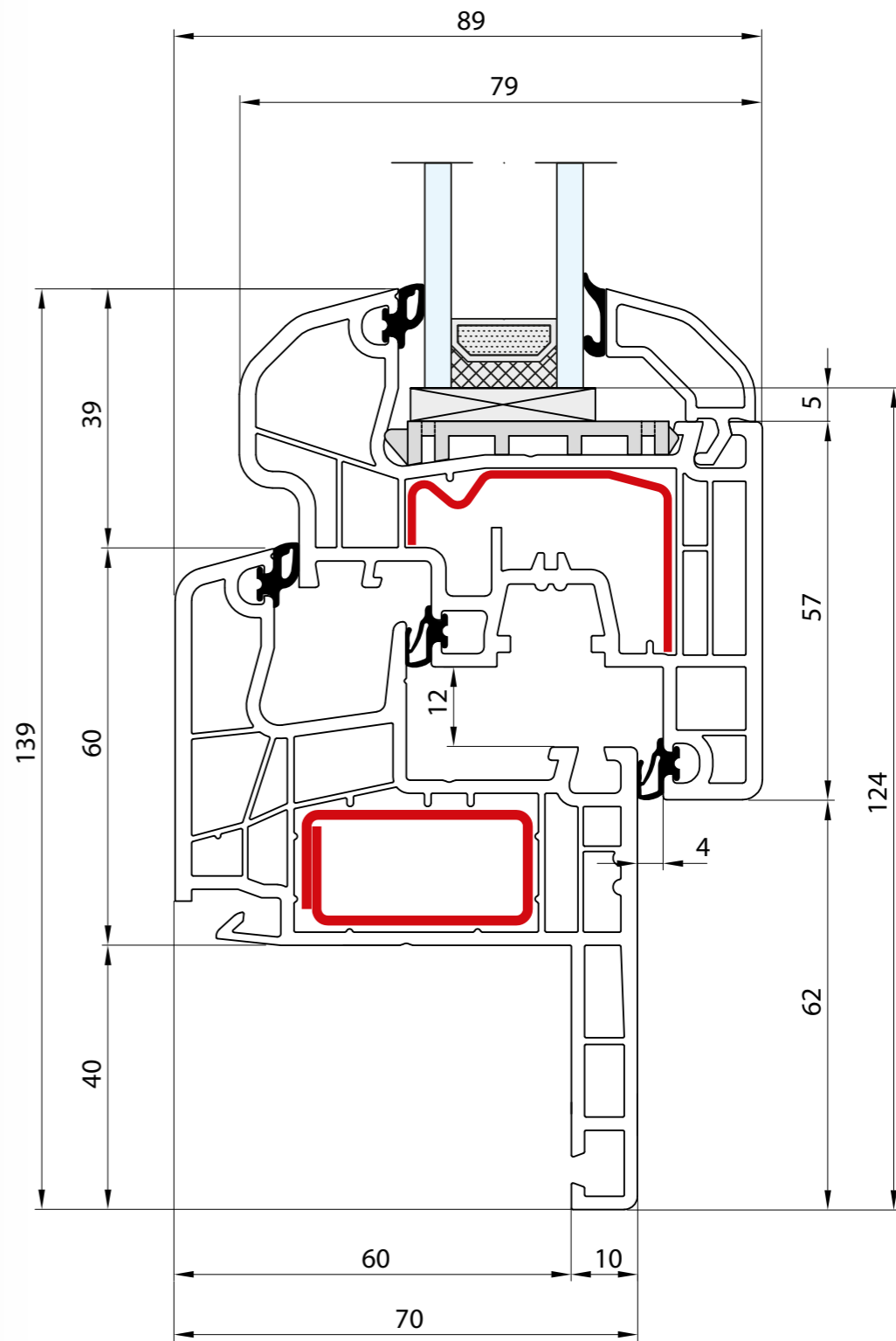

- RENOWACJA - Pletwa: 40 mm · Rama: 60 mm · Skrzydło: 77 mm
- RÉNOVATION - Lip: 40 mm · Dormant: 60 mm · Vantail: 77 mm
- RENOVATION - Strip: 40 mm · Frame: 60 mm · Sash: 77 mm
- RENOVIERUNG - Flosse: 40 mm · Rahmen: 60 mm · Flügel: 77 mm
- RINNOVAZIONE - Aletta da: 40 mm · Telaio: 60 mm · Anta: 77 mm

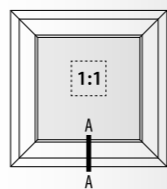
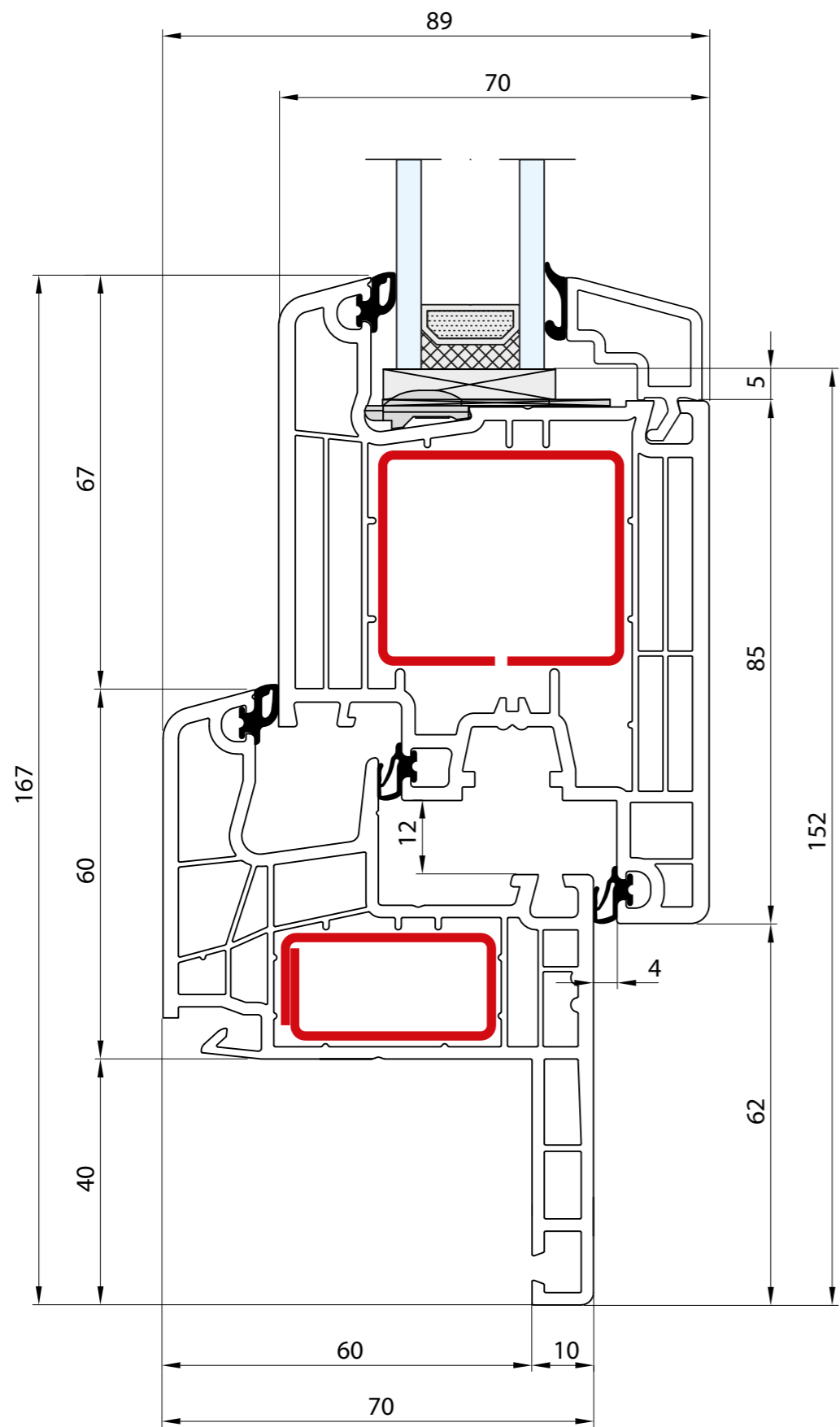



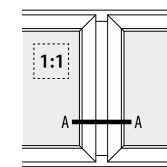
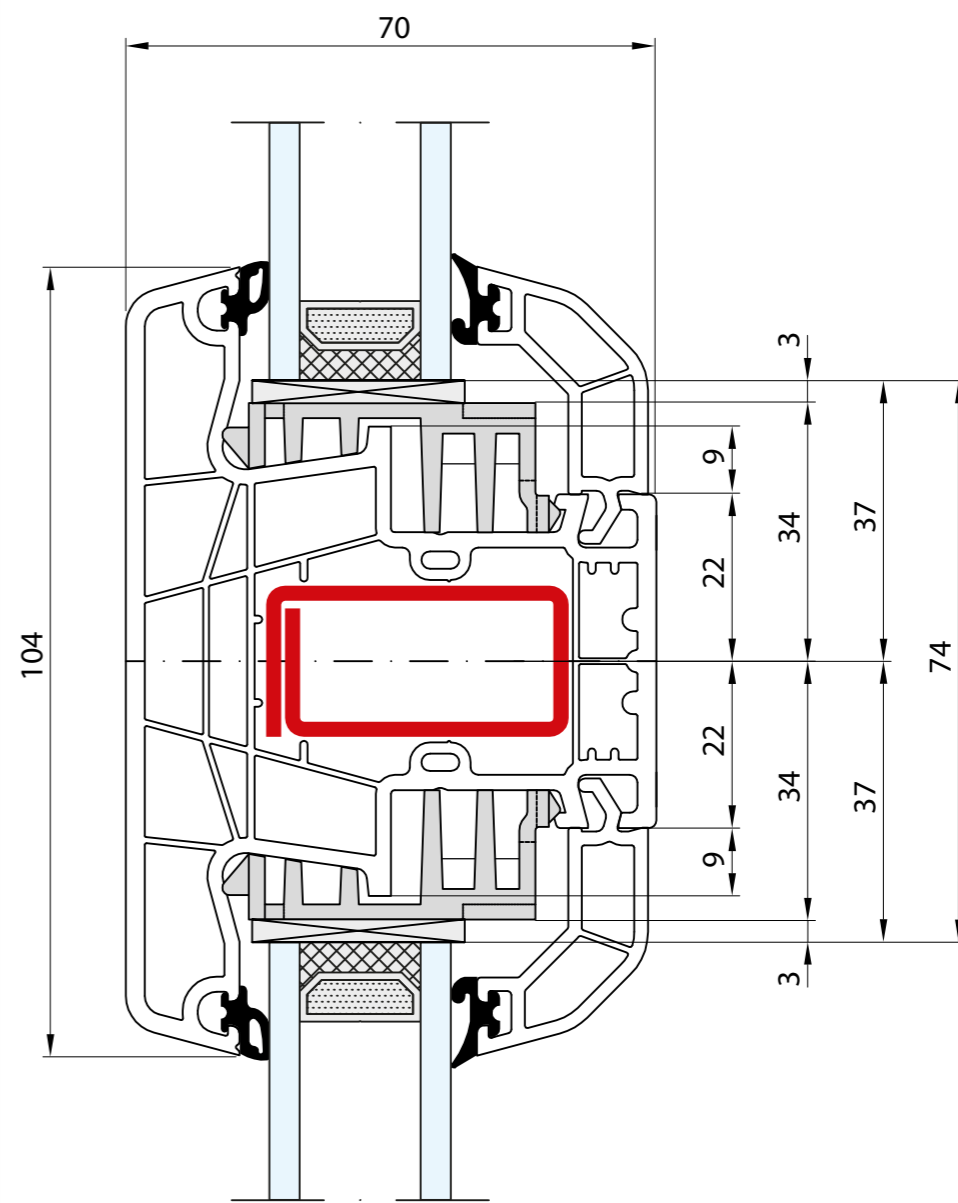

- RENOWACJA - Pletwa: 40 mm · Rama: 60 mm · Skrzydło: 105 mm
- RÉNOVATION - Lip: 40 mm · Dormant: 60 mm · Vantail: 105 mm
- RENOVATION - Strip: 40 mm · Frame: 60 mm · Sash: 105 mm
- RENOVIERUNG - Flosse: 40 mm · Rahmen: 60 mm · Flügel: 105 mm
- RINNOVAZIONE - Aletta da: 40 mm · Telaio: 60 mm · Anta: 105 mm

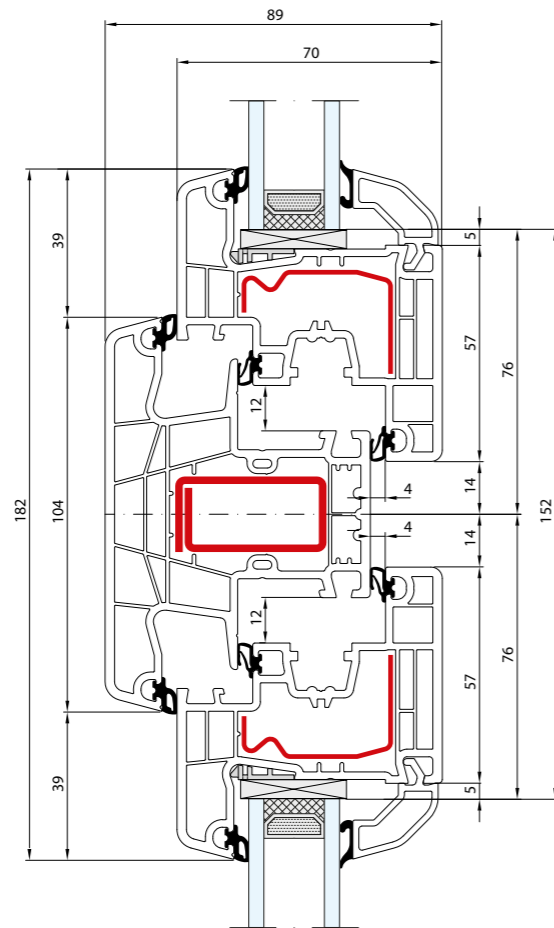





- Słupek stały: 104 mm
- Meneau fixe: 104 mm
- Fix post: 104 mm
- Festem Pfahl: 104 mm
- Montante fisso: 104 mm

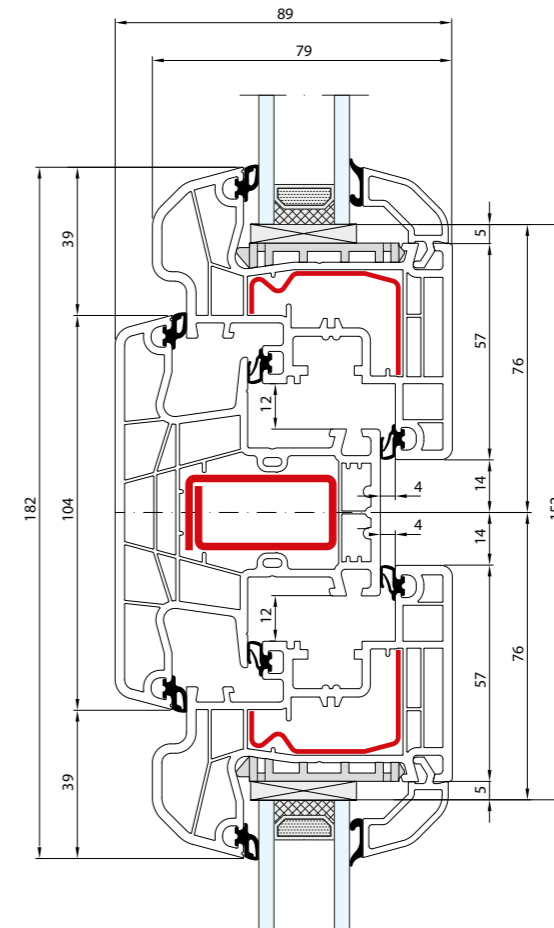
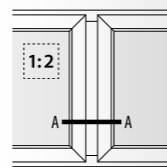

-  Słupek stały: 104 mm · Skrzydło: 77 mm
-  Meneau fixe: 104 mm · Vantail: 77 mm
-  Fix post: 104 mm · Sash: 77 mm
-  Festem Pfahl: 104 mm · Flügel: 77 mm
-  Montante fisso: 104 mm · Anta: 77 mm



-  Słupek stały: 104 mm · Skrzydło: 77 mm
-  Meneau fixe: 104 mm · Vantail: 77 mm
-  Fix post: 104 mm · Sash: 77 mm
-  Festem Pfahl: 104 mm · Flügel: 77 mm
-  Montante fisso: 104 mm · Anta: 77 mm

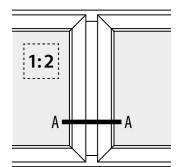

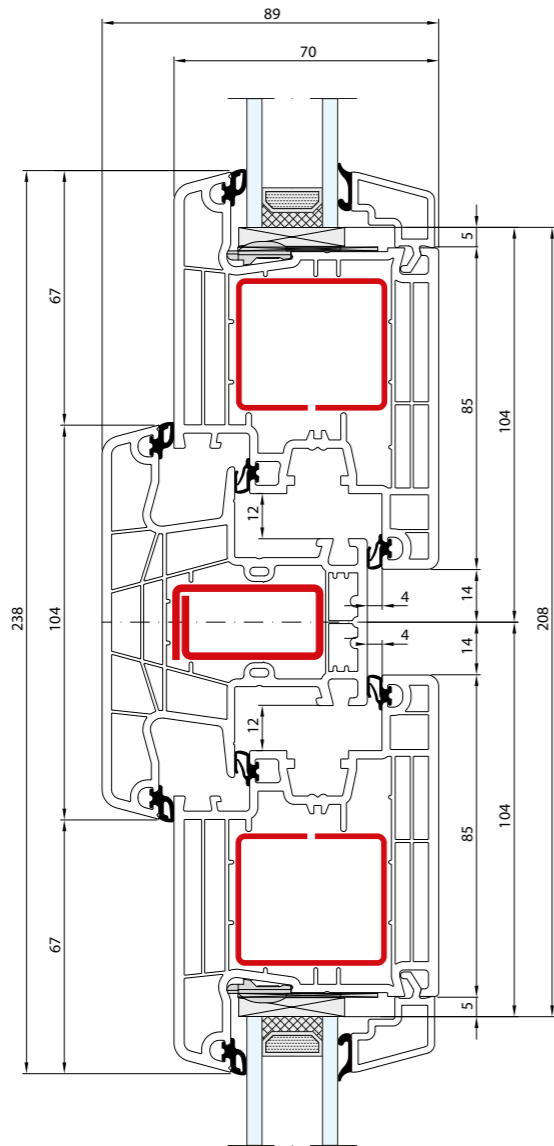

- Słupek stały: 104 mm · Skrzydło: 105 mm
- Meneau fixe: 104 mm · Vantail: 105 mm
- Fix post: 104 mm · Sash: 105 mm
- Festem Pfahl: 104 mm · Flügel: 105 mm
- Montante fisso: 104 mm · Anta: 105 mm

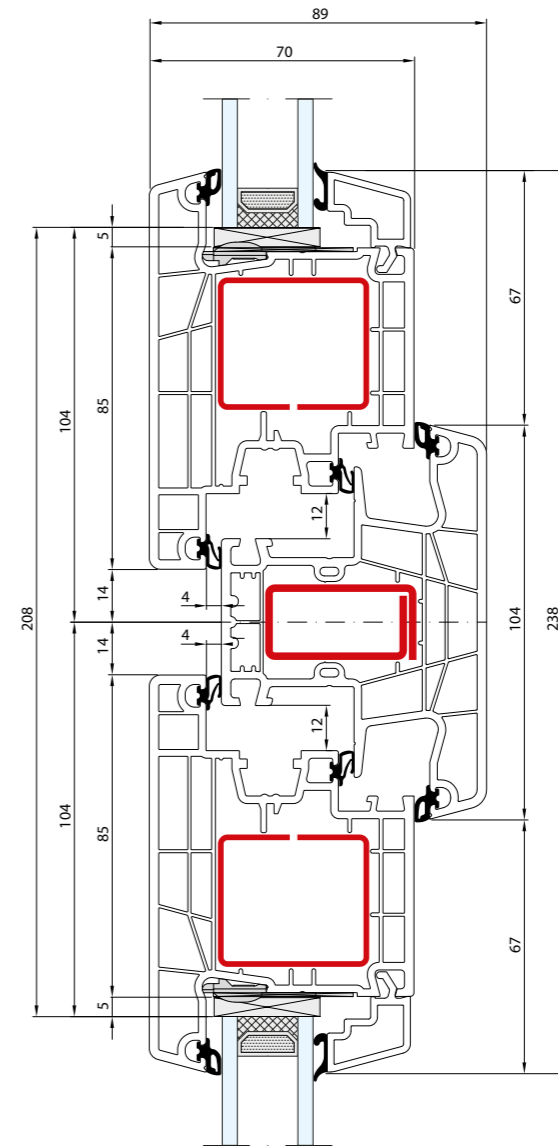
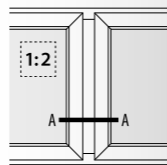

- Słupek stały: 104 mm · Skrzydło: 105 mm
- Meneau fixe: 104 mm · Vantail: 105 mm
- Fix post: 104 mm · Sash: 105 mm
- Festem Pfahl: 104 mm · Flügel: 105 mm
- Montante fisso: 104 mm · Anta: 105 mm

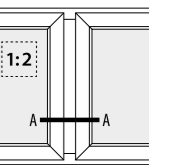

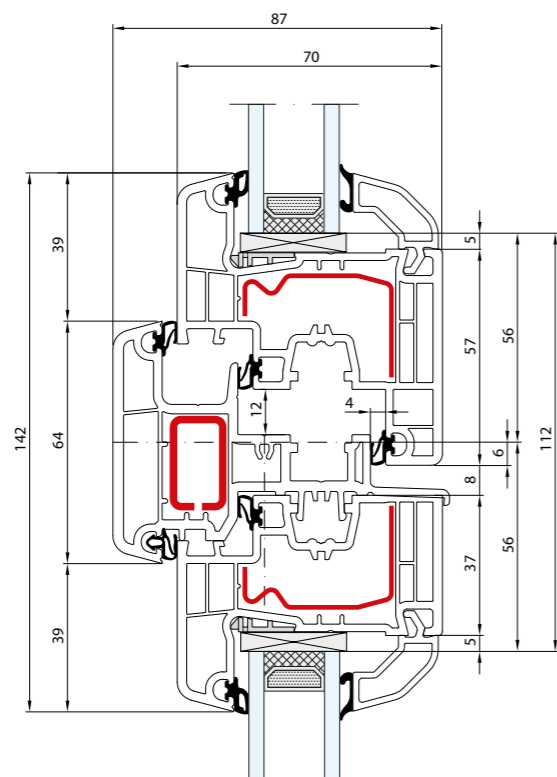

- Słupek ruchomy: 64 mm · Skrzydło: 77 mm / 57 mm
- Meneau mobile: 64 mm · Vantail: 77 mm / 57 mm
- Movable post: 64 mm · Sash: 77 mm / 57 mm
- Stulp: 64 mm · Flügel: 77 mm / 57 mm
- Montante mobile: 64 mm · Anta: 77 mm / 57 mm

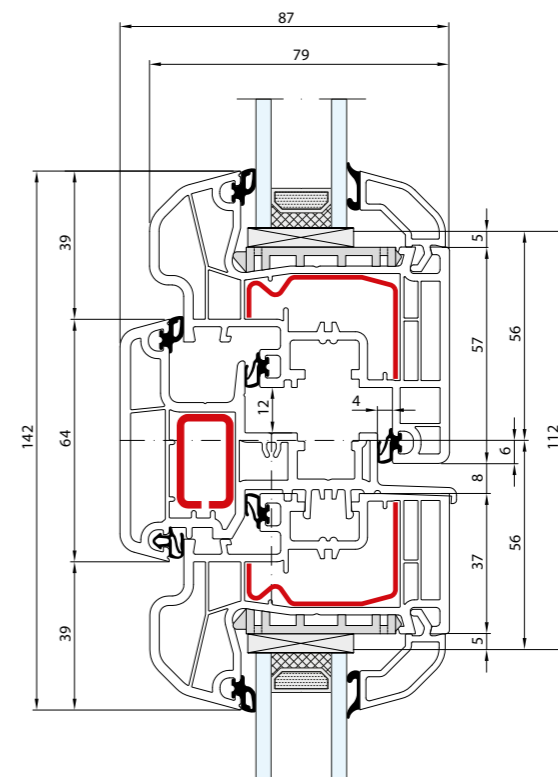
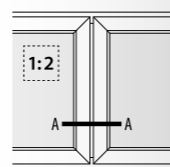



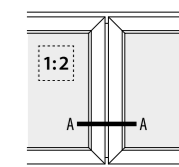

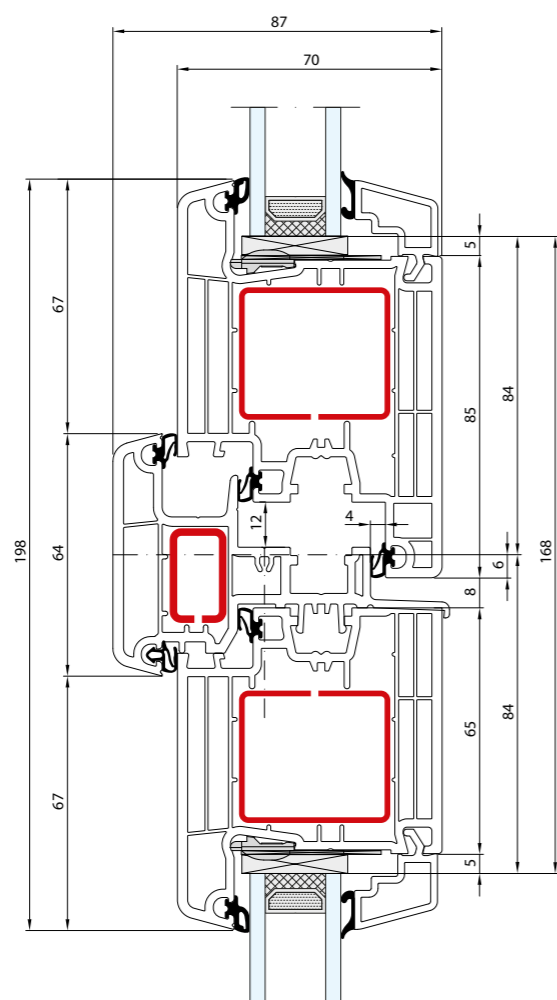

- Słupek ruchomy: 64 mm · Skrzydło: 77 mm / 57 mm
- Meneau mobile: 64 mm · Vantail: 77 mm / 57 mm
- Movable post: 64 mm · Sash: 77 mm / 57 mm
- Stulp: 64 mm · Flügel: 77 mm / 57 mm
- Montante mobile: 64 mm · Anta: 77 mm / 57 mm

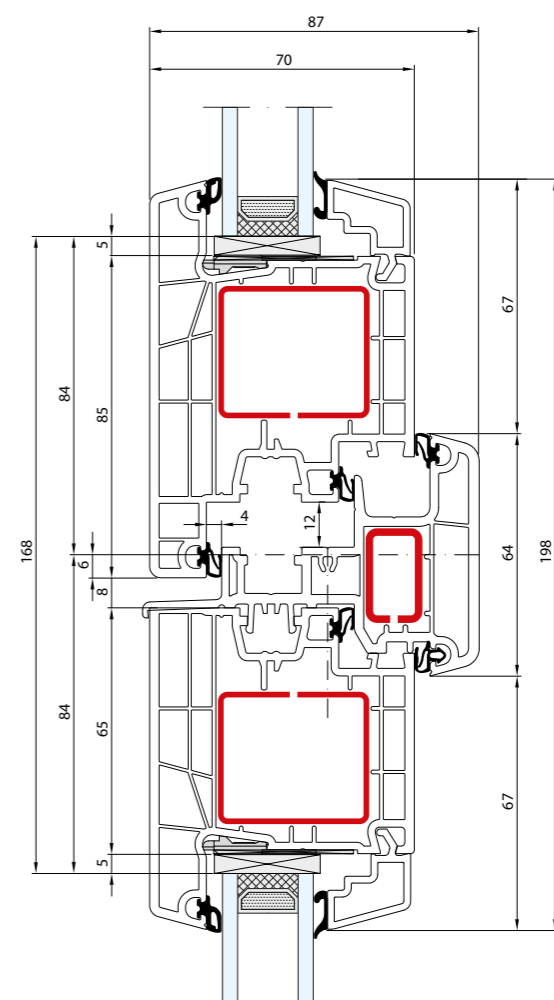
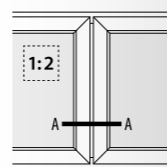



-  Słupek ruchomy: 64 mm · Skrzydło: 105 mm / 85 mm
-  Meneau mobile: 64 mm · Vantail: 105 mm / 85 mm
-  Movable post: 64 mm · Sash: 105 mm / 85 mm
-  Stulp: 64 mm · Flügel: 105 mm / 85 mm
-  Montante mobile: 64 mm · Anta: 105 mm / 85 mm



-  Słupek ruchomy: 64 mm · Skrzydło: 105 mm / 85 mm
-  Meneau mobile: 64 mm · Vantail: 105 mm / 85 mm
-  Movable post: 64 mm · Sash: 105 mm / 85 mm
-  Stulp: 64 mm · Flügel: 105 mm / 85 mm
-  Montante mobile: 64 mm · Anta: 105 mm / 85 mm

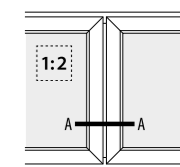

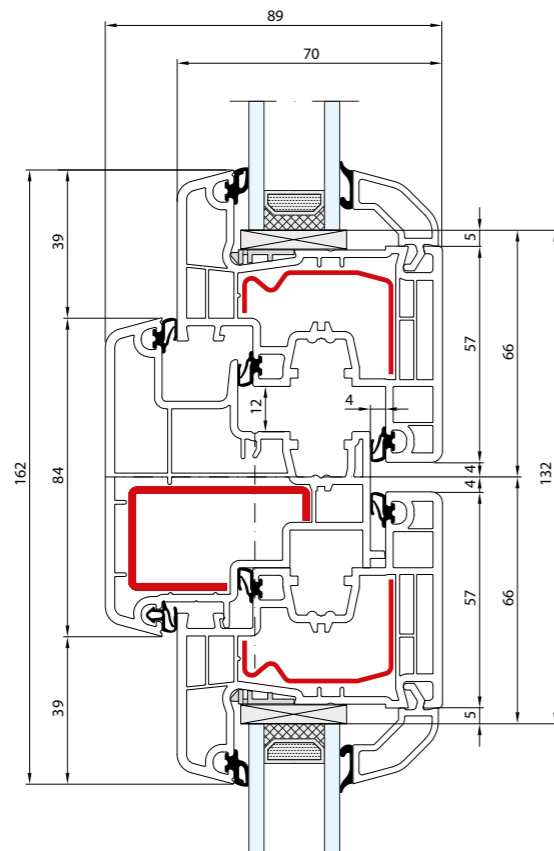

- Słupek ruchomy: 84 mm · Skrzydło: 77 mm
- Meneau mobile: 84 mm · Vantail: 77 mm
- Movable post: 84 mm · Sash: 77 mm
- Stulp: 84 mm · Flügel: 77 mm
- Montante mobile: 84 mm · Anta: 77 mm

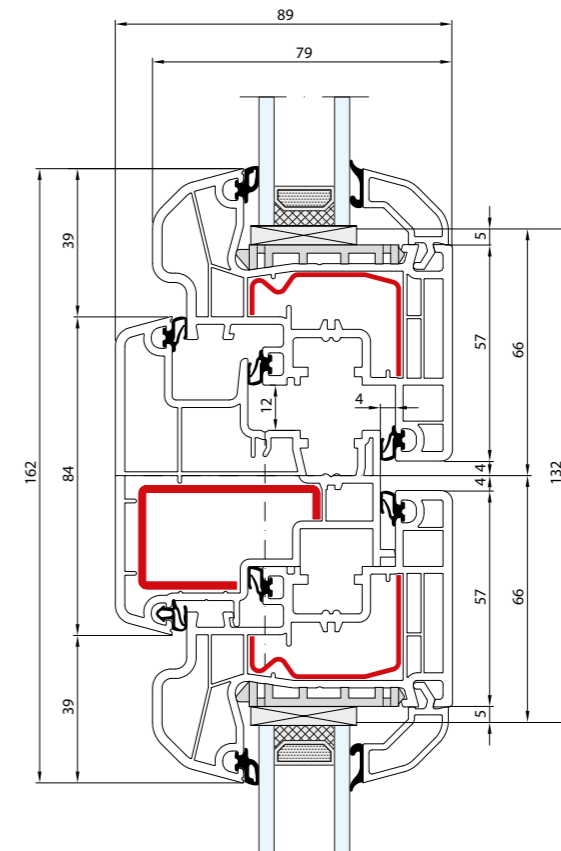
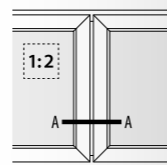

- Słupek ruchomy: 84 mm · Skrzydło: 77 mm
- Meneau mobile: 84 mm · Vantail: 77 mm
- Movable post: 84 mm · Sash: 77 mm
- Stulp: 84 mm · Flügel: 77 mm
- Montante mobile: 84 mm · Anta: 77 mm

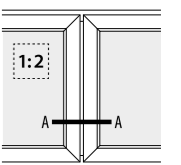

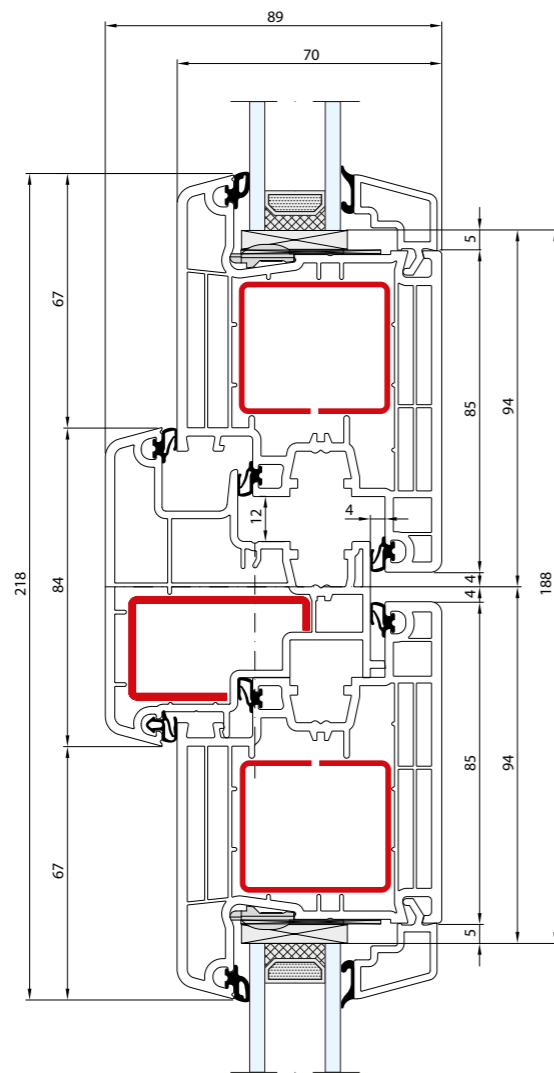

- Słupek ruchomy: 84 mm · Skrzydło: 105 mm
- Meneau mobile: 84 mm · Vantail: 105 mm
- Movable post: 84 mm · Sash: 105 mm
- Stulp: 84 mm · Flügel: 105 mm
- Montante mobile: 84 mm · Anta: 105 mm

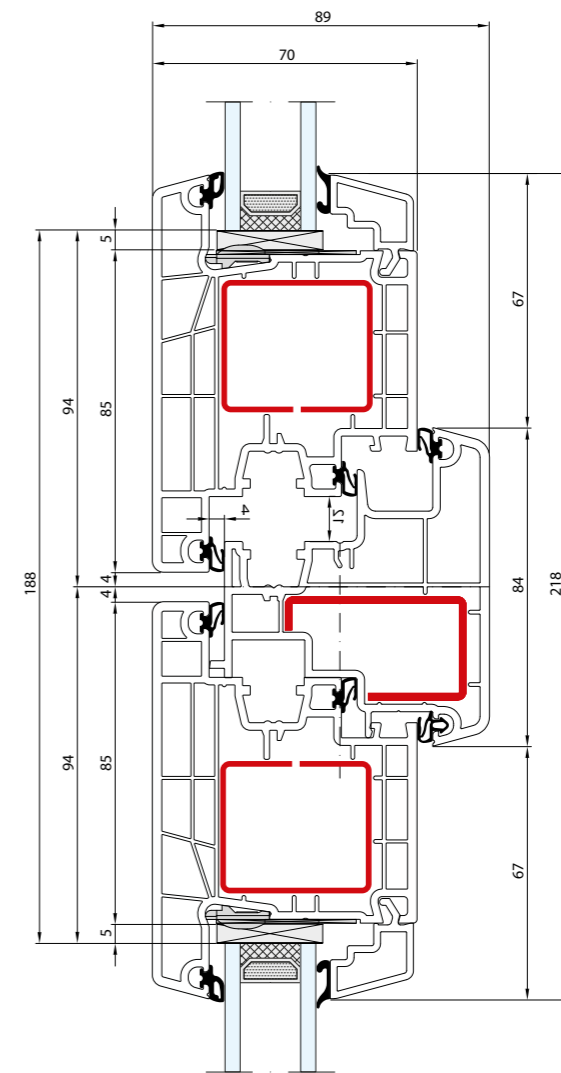
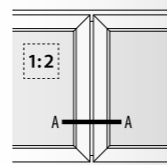

- Słupek ruchomy: 84 mm · Skrzydło: 105 mm
- Meneau mobile: 84 mm · Vantail: 105 mm
- Movable post: 84 mm · Sash: 105 mm
- Stulp: 84 mm · Flügel: 105 mm
- Montante mobile: 84 mm · Anta: 105 mm

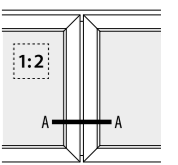

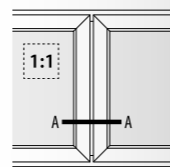
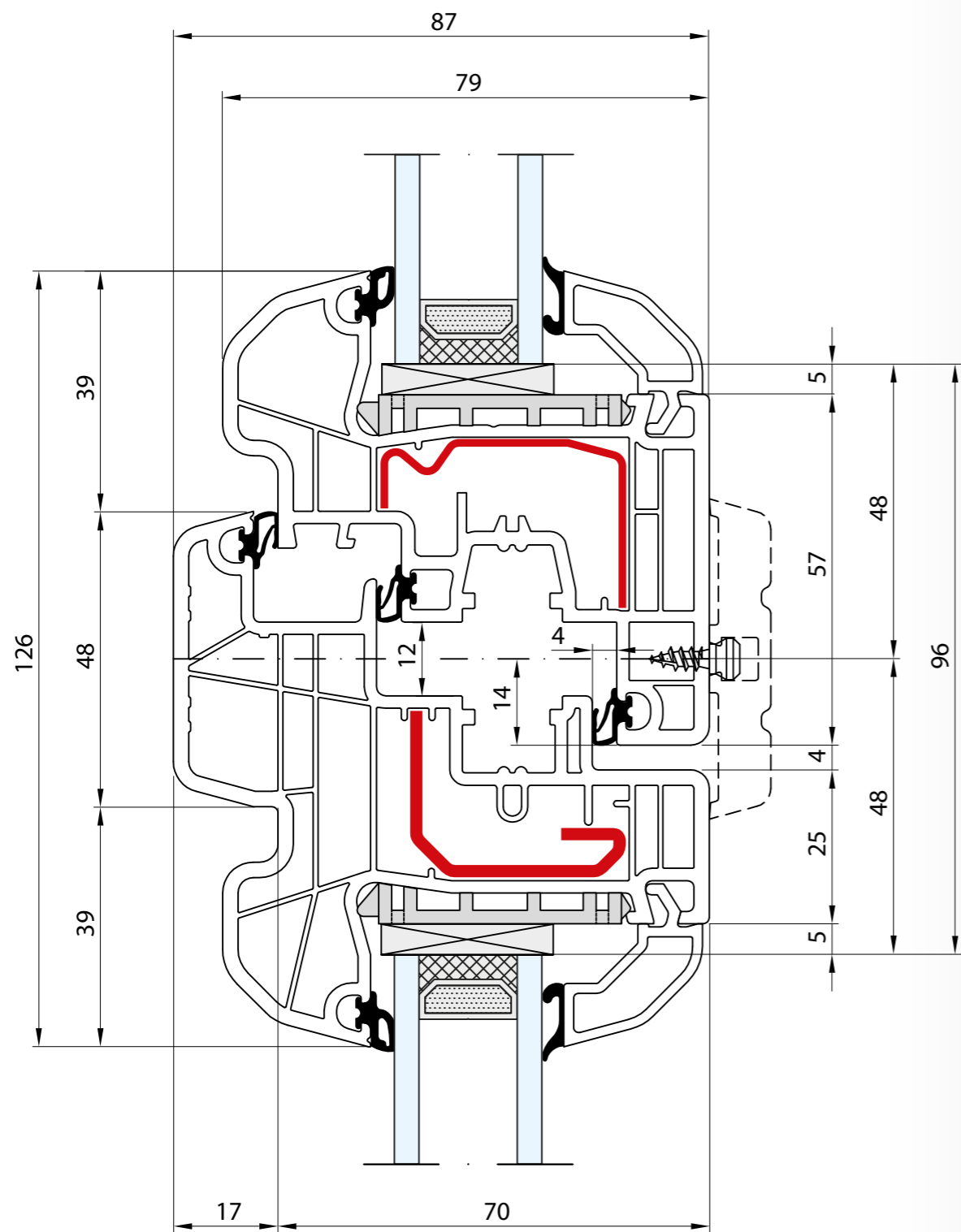

- Klamka centralna · Skrzydło: 77 mm
- Battue centrée · Vantail: 77 mm
- Central handle · Sash: 77 mm
- Zentrale Olive · Flügel: 77 mm
- Maniglia centrale · Anta: 77 mm

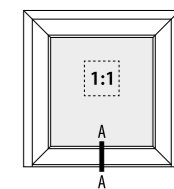
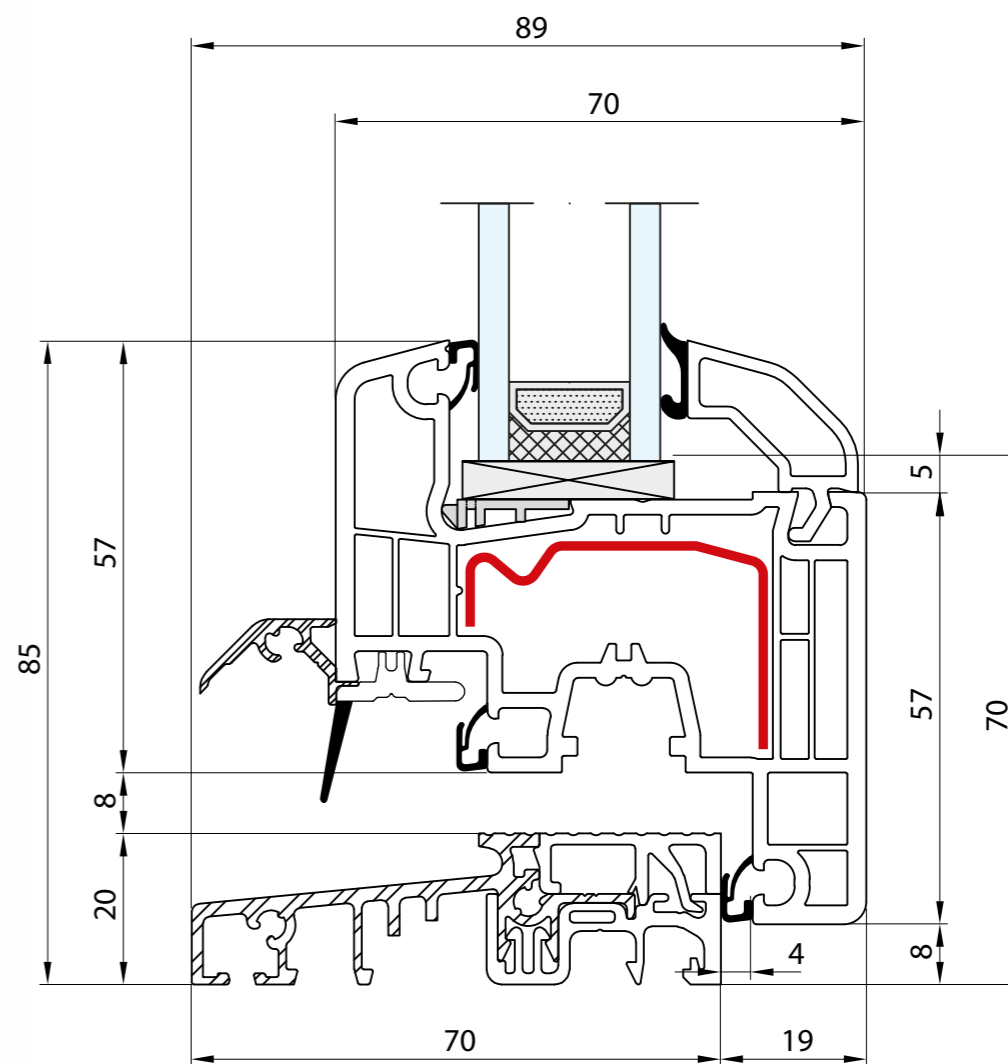

- Próg: 20 mm · Skrzydło: 77 mm
- Seuil: 20 mm · Vantail: 77 mm
- Threshold: 20 mm · Sash: 77 mm
- Schwelle: 20 mm · Flügel: 77 mm
- Soglia: 20 mm · Anta: 77 mm

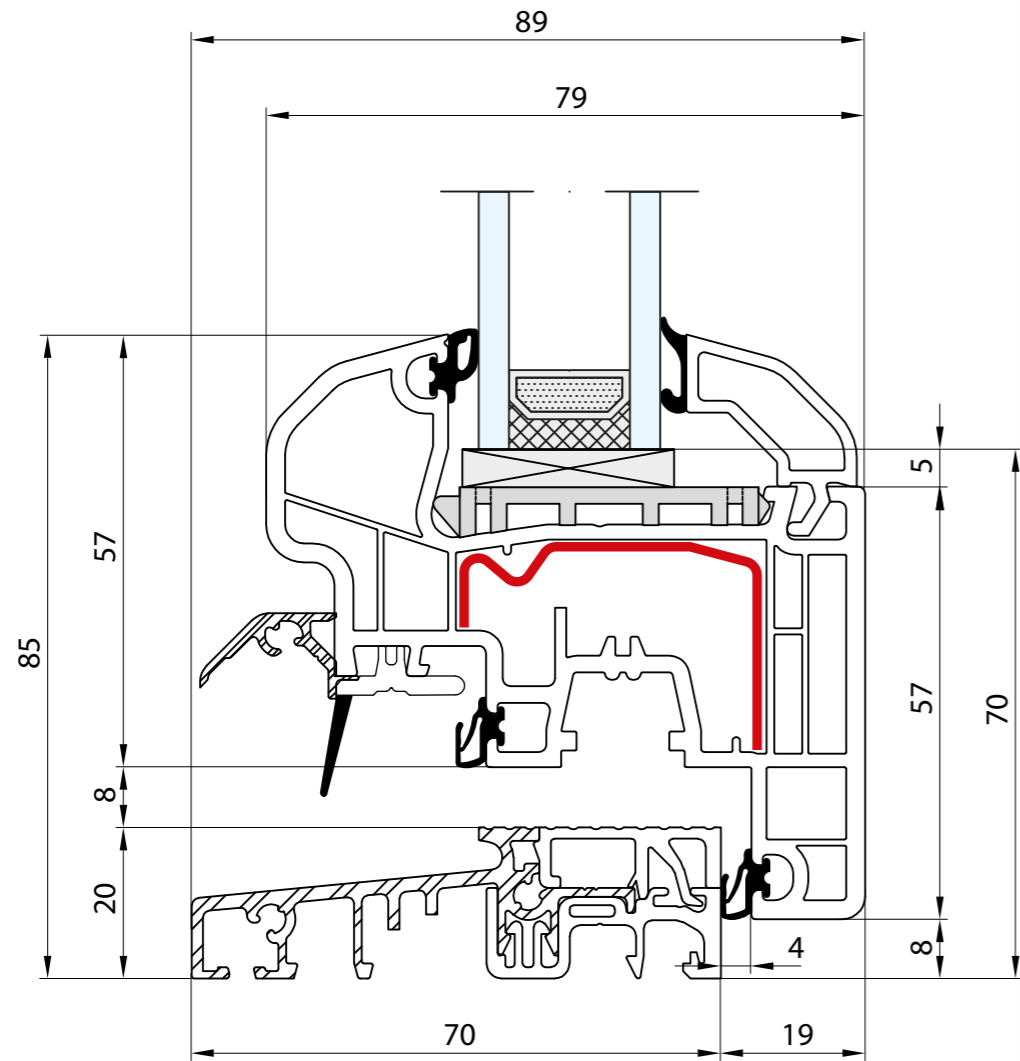

- Próg: 20 mm · Skrzydło: 77 mm
- Seuil: 20 mm · Vantail: 77 mm
- Threshold: 20 mm · Sash: 77 mm
- Schwelle: 20 mm · Flügel: 77 mm
- Soglia: 20 mm · Anta: 77 mm

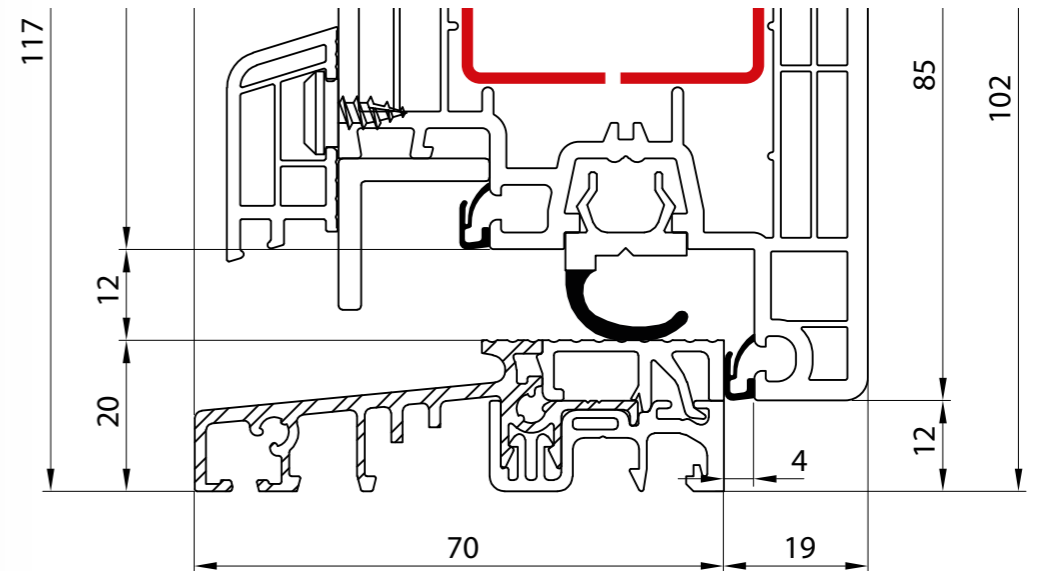
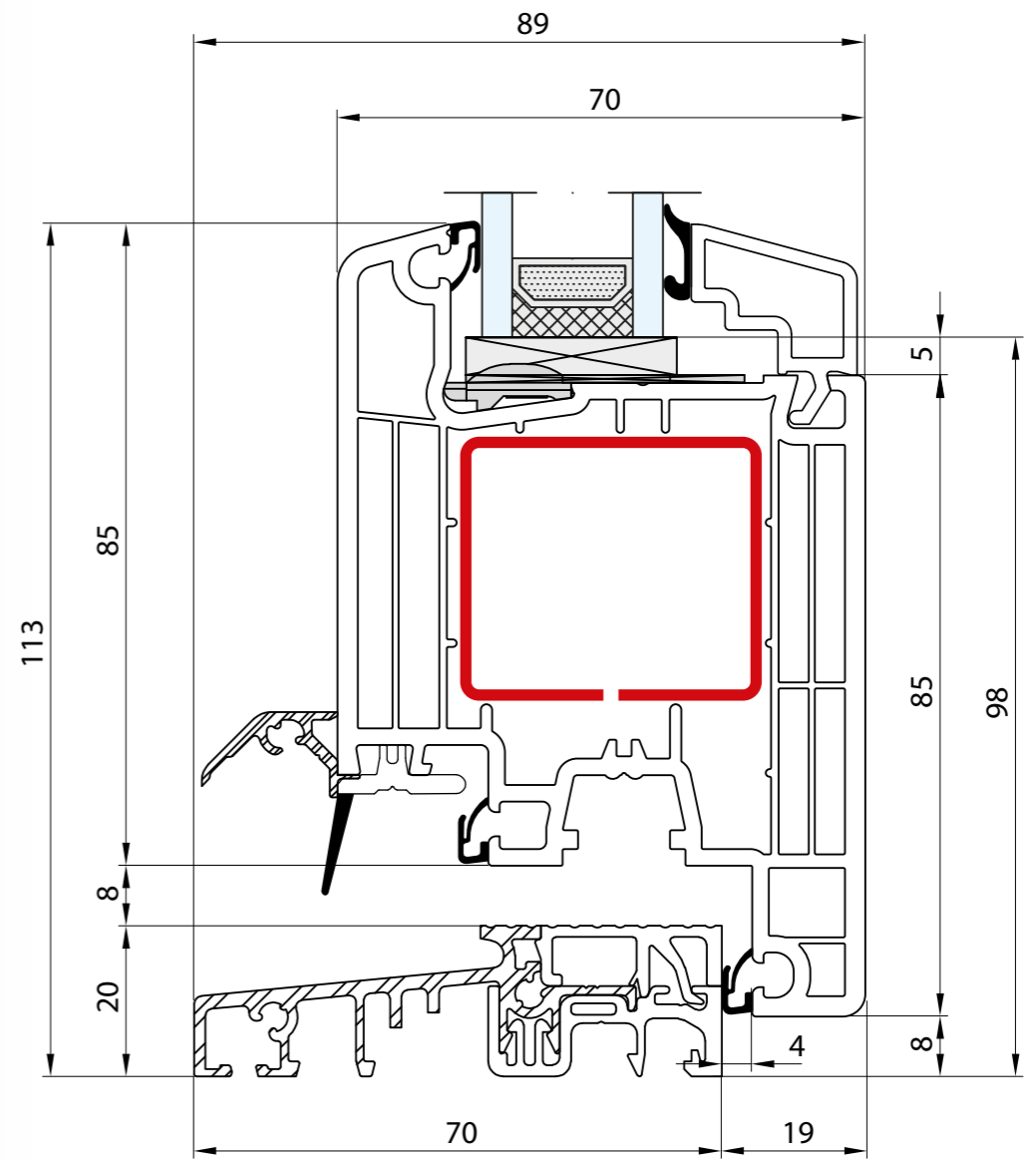
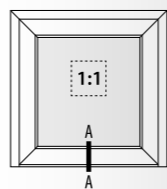

- Próg: 20 mm · Skrzydło: 105 mm
- Seuil: 20 mm · Vantail: 105 mm
- Threshold: 20 mm · Sash: 105 mm
- Schwelle: 20 mm · Flügel: 105 mm
- Soglia: 20 mm · Anta: 105 mm

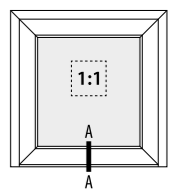

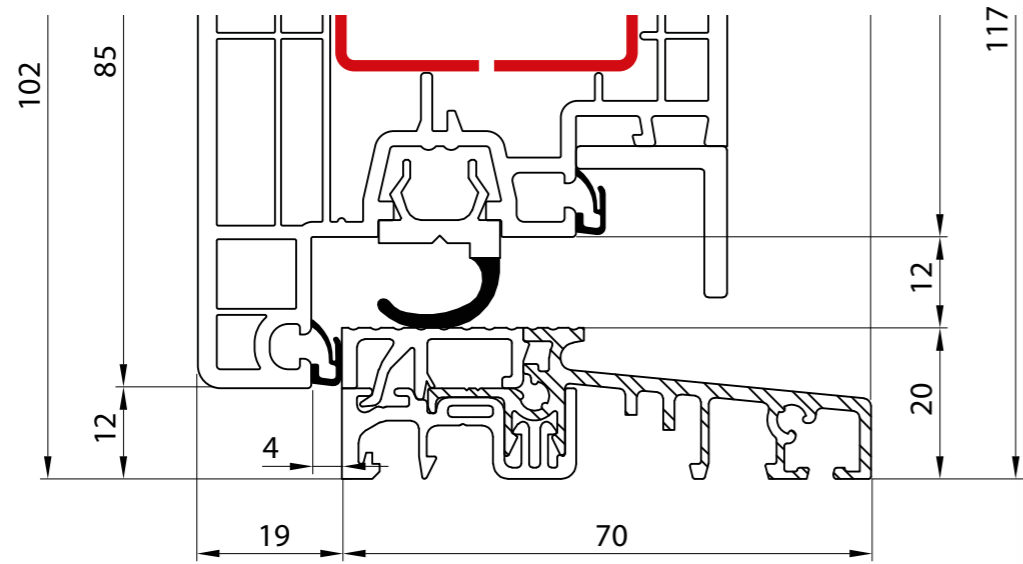
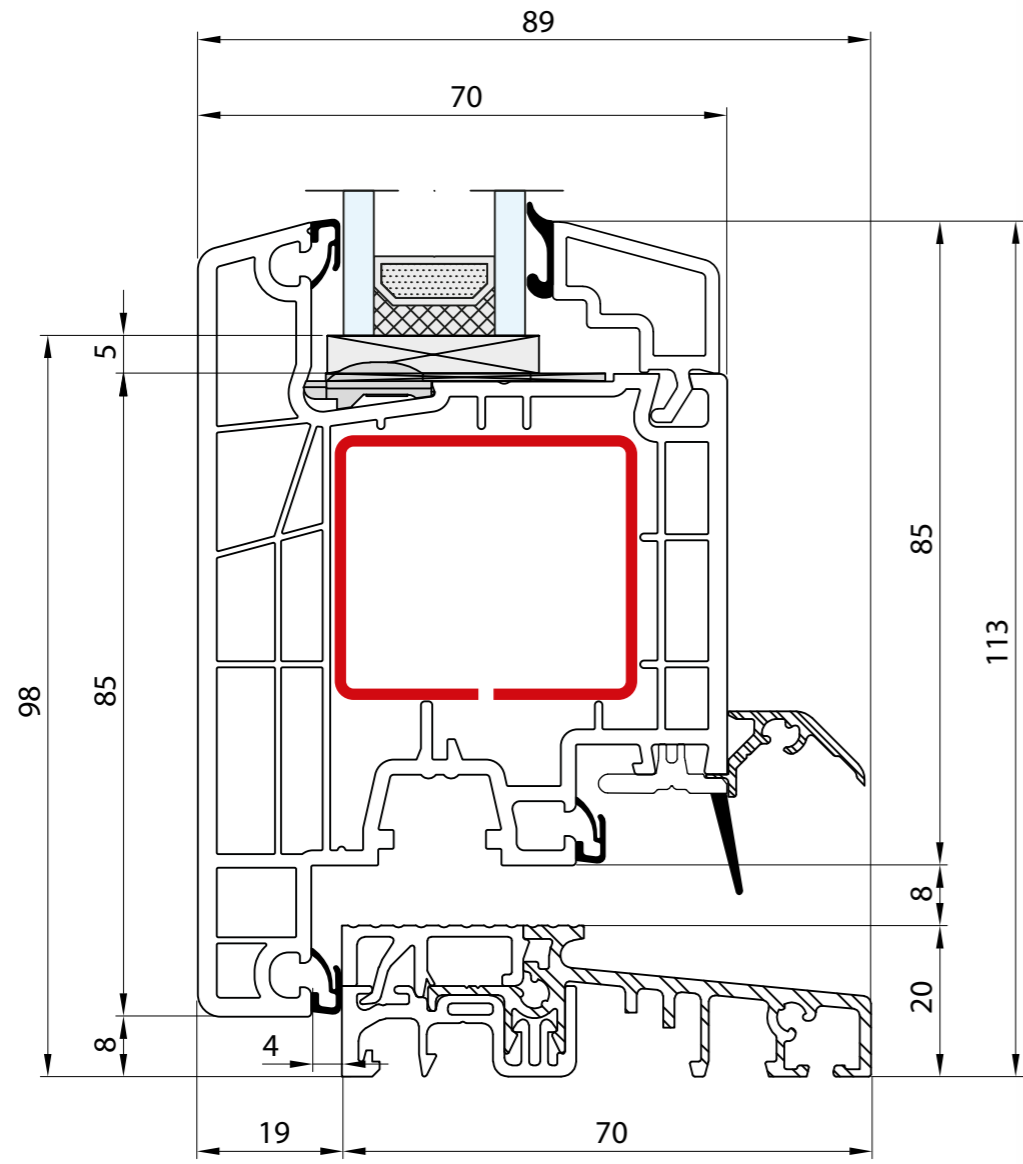

- Próg: 20 mm · Skrzydło: 105 mm
- Seuil: 20 mm · Vantail: 105 mm
- Threshold: 20 mm · Sash: 105 mm
- Schwelle: 20 mm · Flügel: 105 mm
- Soglia: 20 mm · Anta: 105 mm

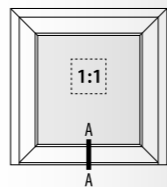

IDEAL 7000 NEW

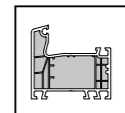
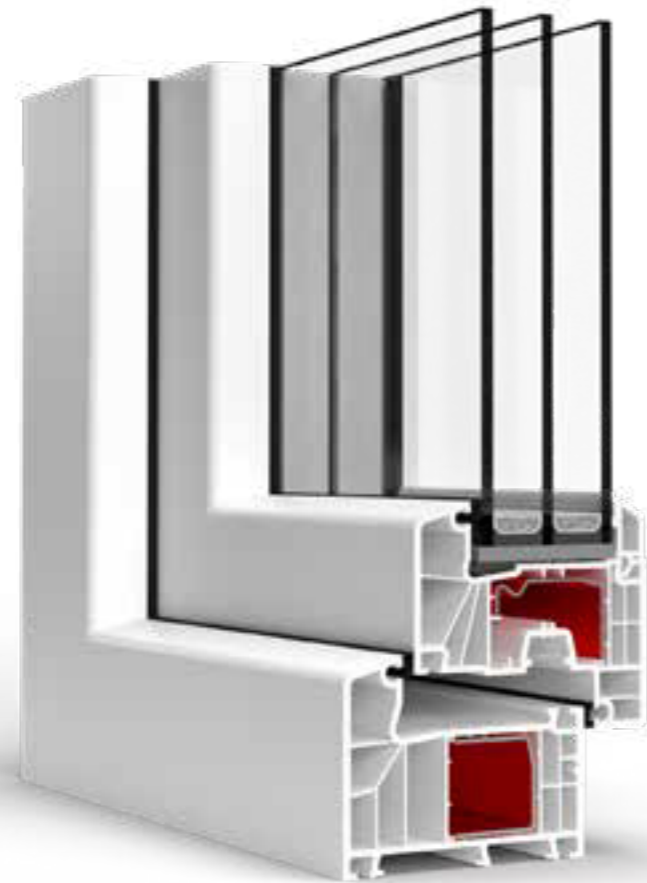

6



2

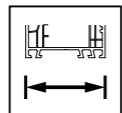

85

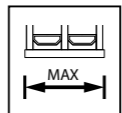

52



V-SUPER SOLUTION



V-PERFECT TECHNOLOGY

IDEAL 4000

IDEAL 6000 NEW

IDEAL 5000

IDEAL 7000 NEW

IDEAL 8000

ENERGETO 8000

IDEAL 4000

IDEAL 6000 NEW

IDEAL 5000

IDEAL 7000 NEW

IDEAL 8000

ENERGETO 8000

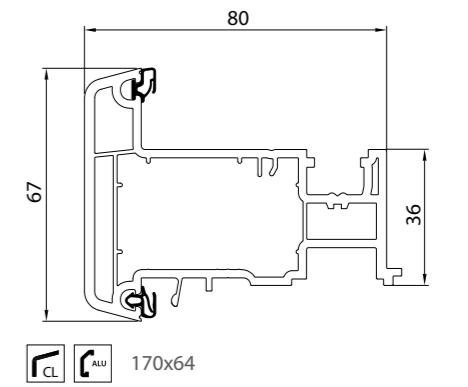
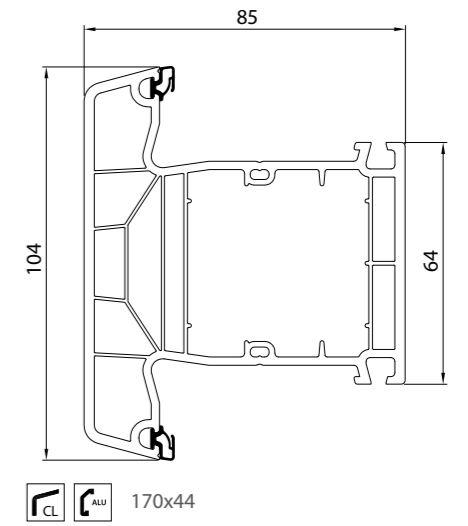
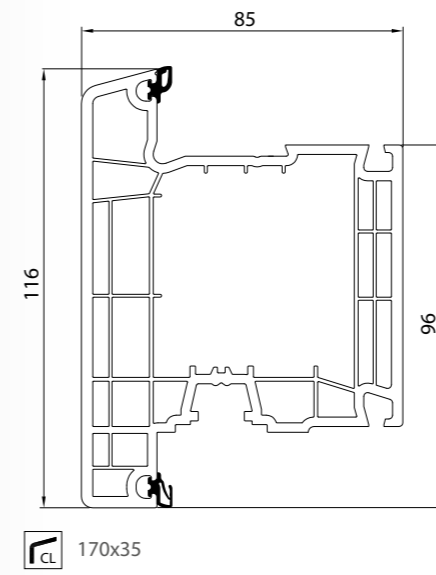
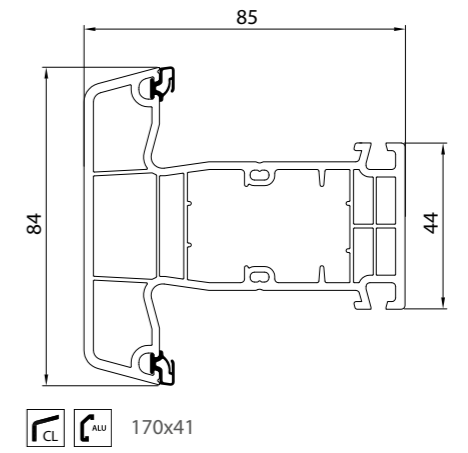
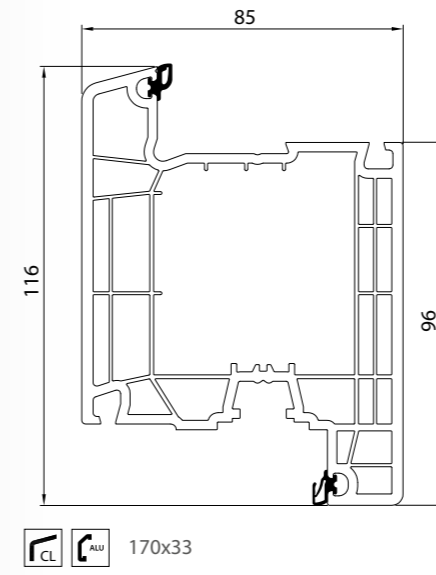
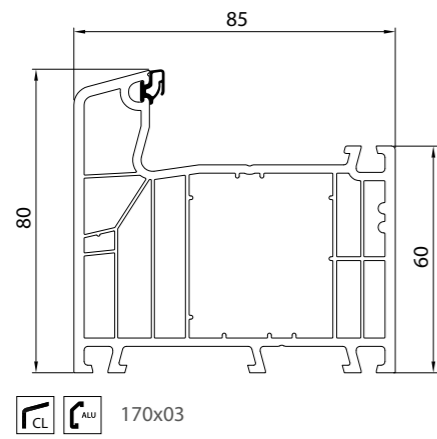
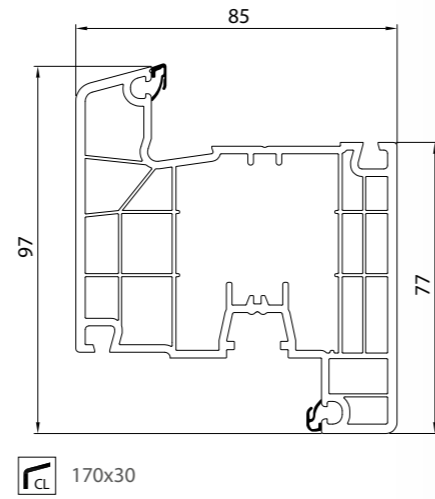
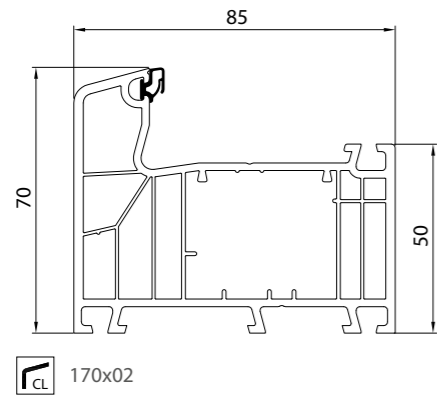
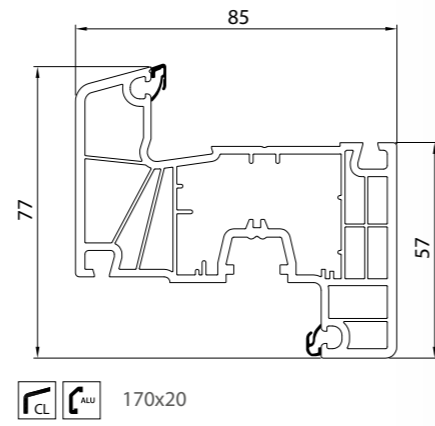
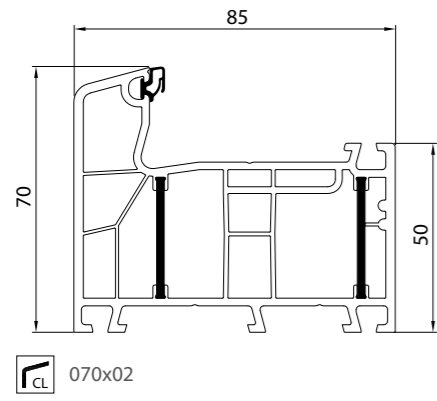

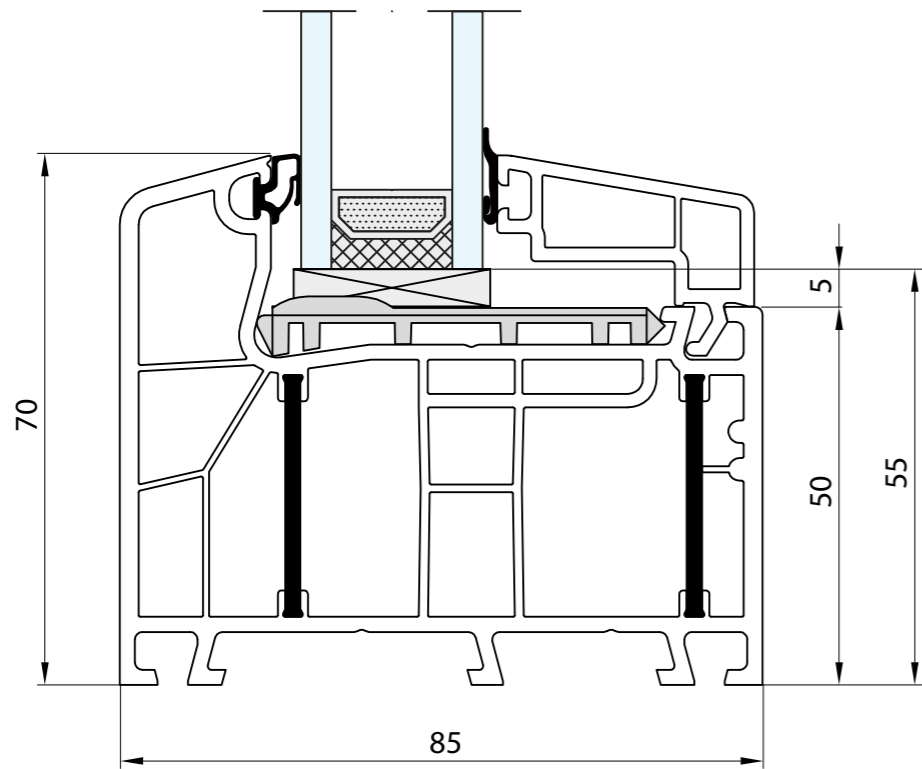

- Rama: 70 mm
- Dormant: 70 mm
- Frame: 70 mm
- Rahmen: 70 mm
- Telaio: 70 mm

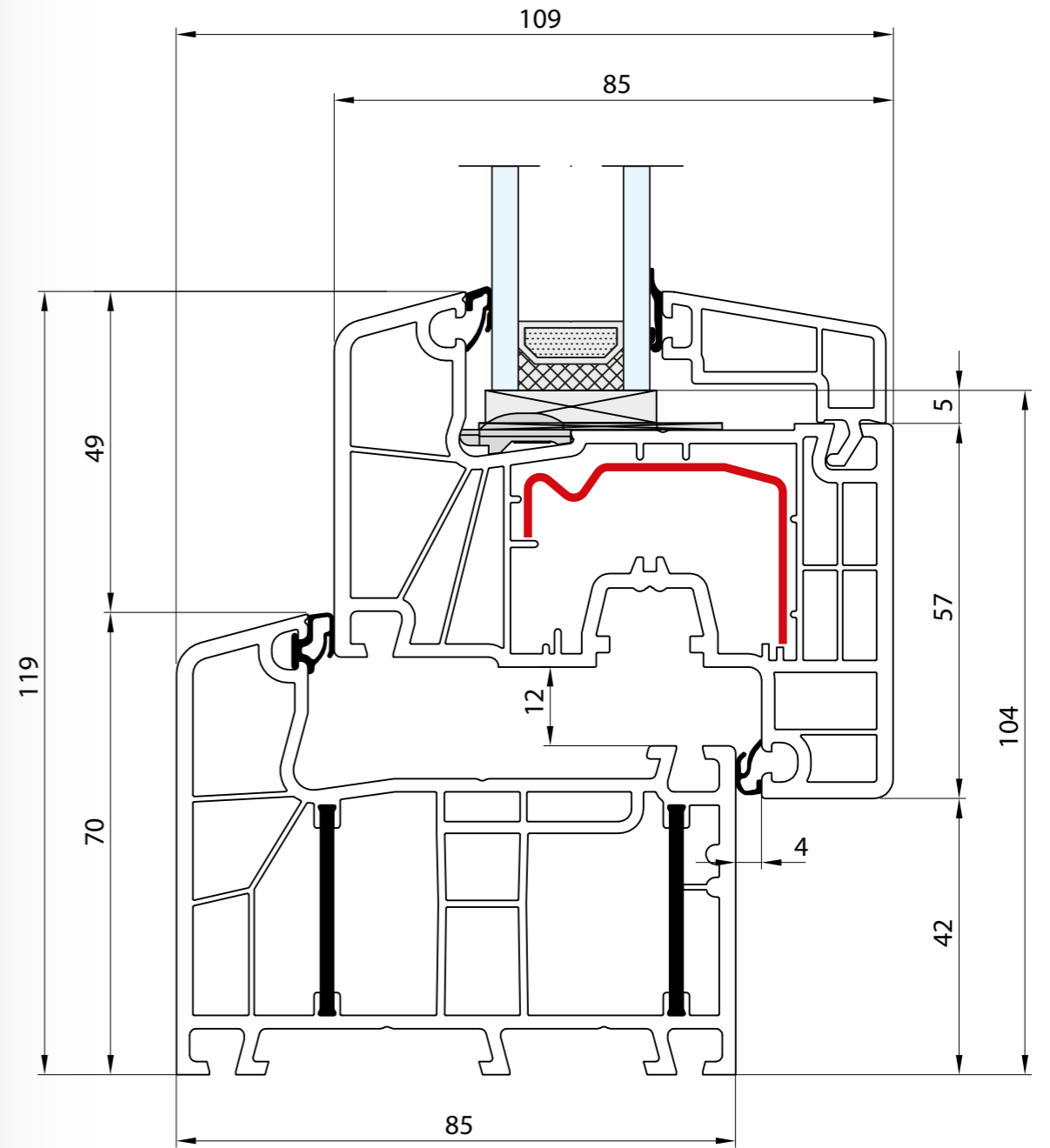
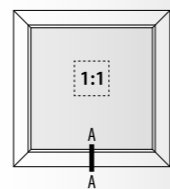

- Rama: 70 mm · Skrzydło: 97 mm
- Dormant: 70 mm · Vantail: 97 mm
- Frame: 70 mm · Sash: 97 mm
- Rahmen: 70 mm · Flügel: 97 mm
- Telaio: 70 mm · Anta: 97 mm

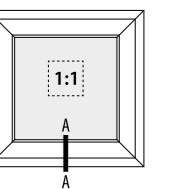

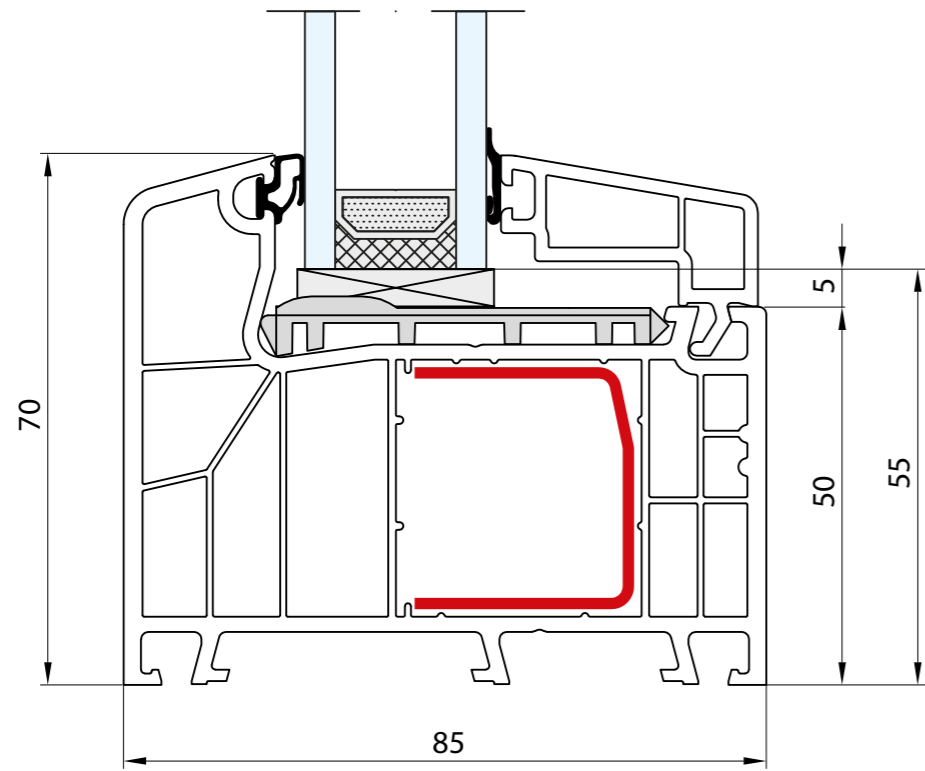

- Rama: 70 mm
- Dormant: 70 mm
- Frame: 70 mm
- Rahmen: 70 mm
- Telaio: 70 mm

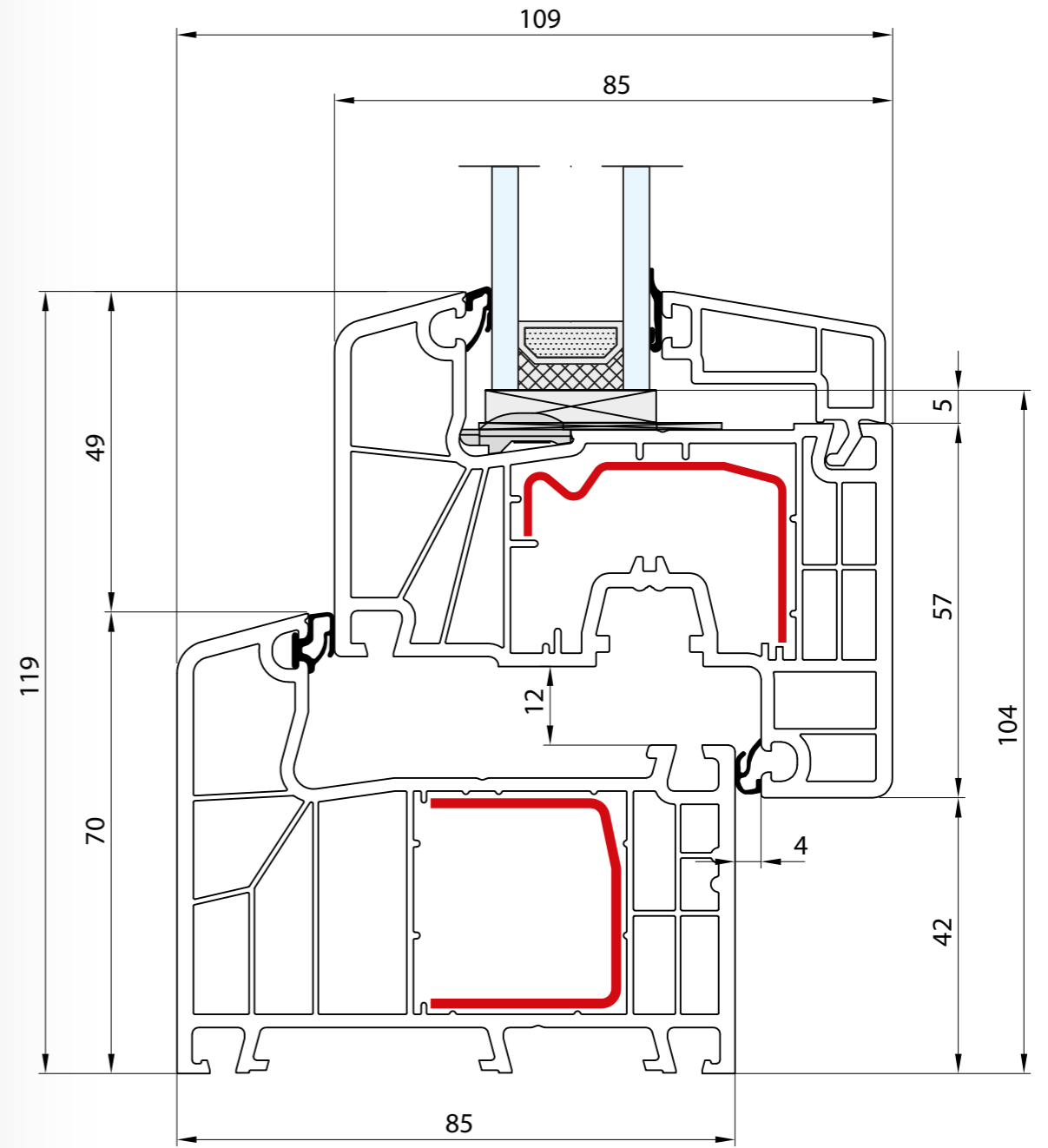
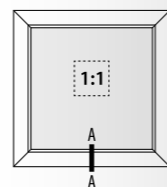

- Rama: 70 mm · Skrzydło: 77 mm
- Dormant: 70 mm · Vantail: 77 mm
- Frame: 70 mm · Sash: 77 mm
- Rahmen: 70 mm · Flügel: 77 mm
- Telaio: 70 mm · Anta: 77 mm

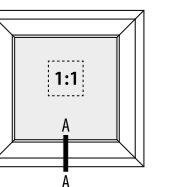

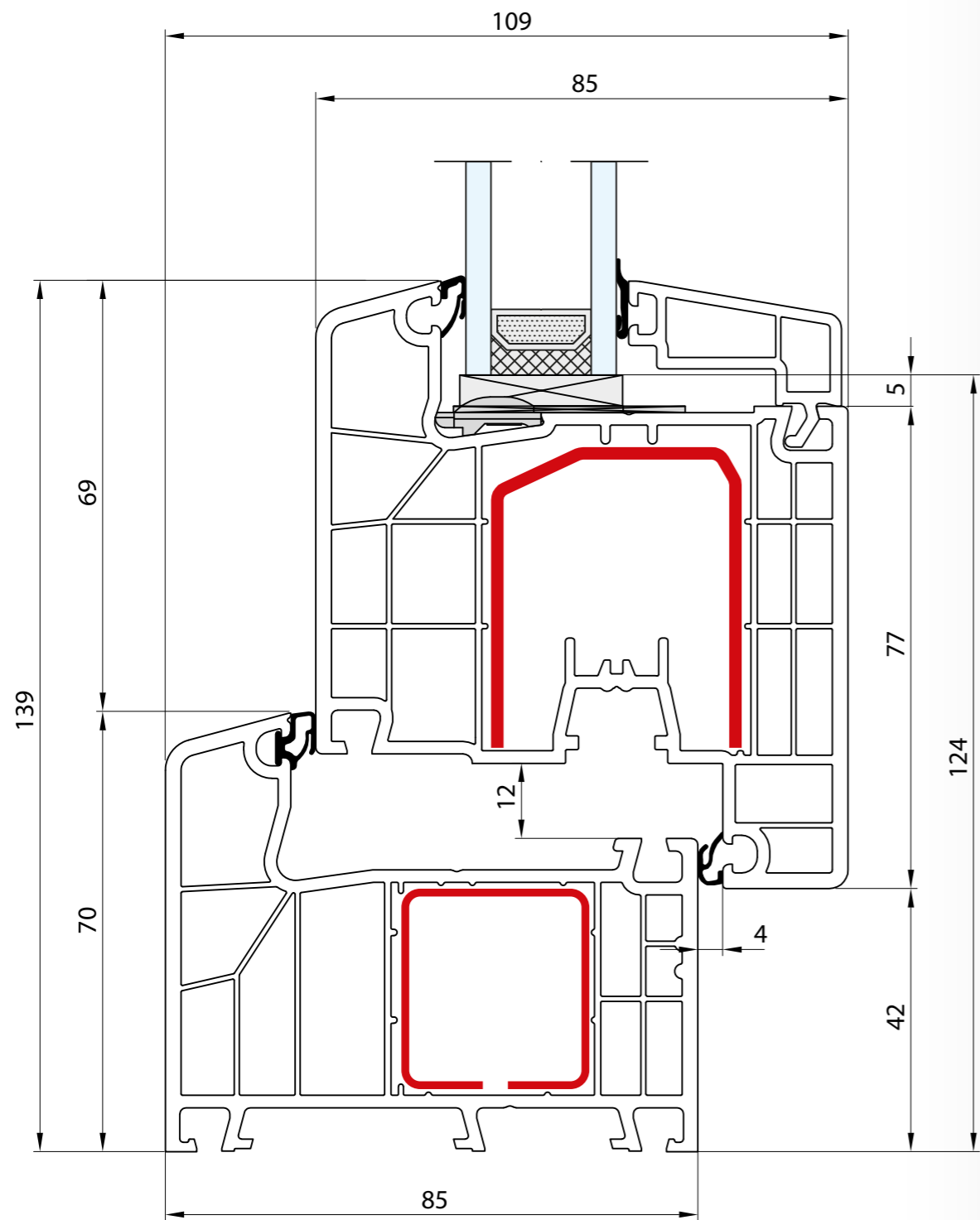

- Rama: 70 mm · Skrzydło: 97 mm
- Dormant: 70 mm · Vantail: 97 mm
- Frame: 70 mm · Sash: 97 mm
- Rahmen: 70 mm · Flügel: 97 mm
- Telaio: 70 mm · Anta: 97 mm

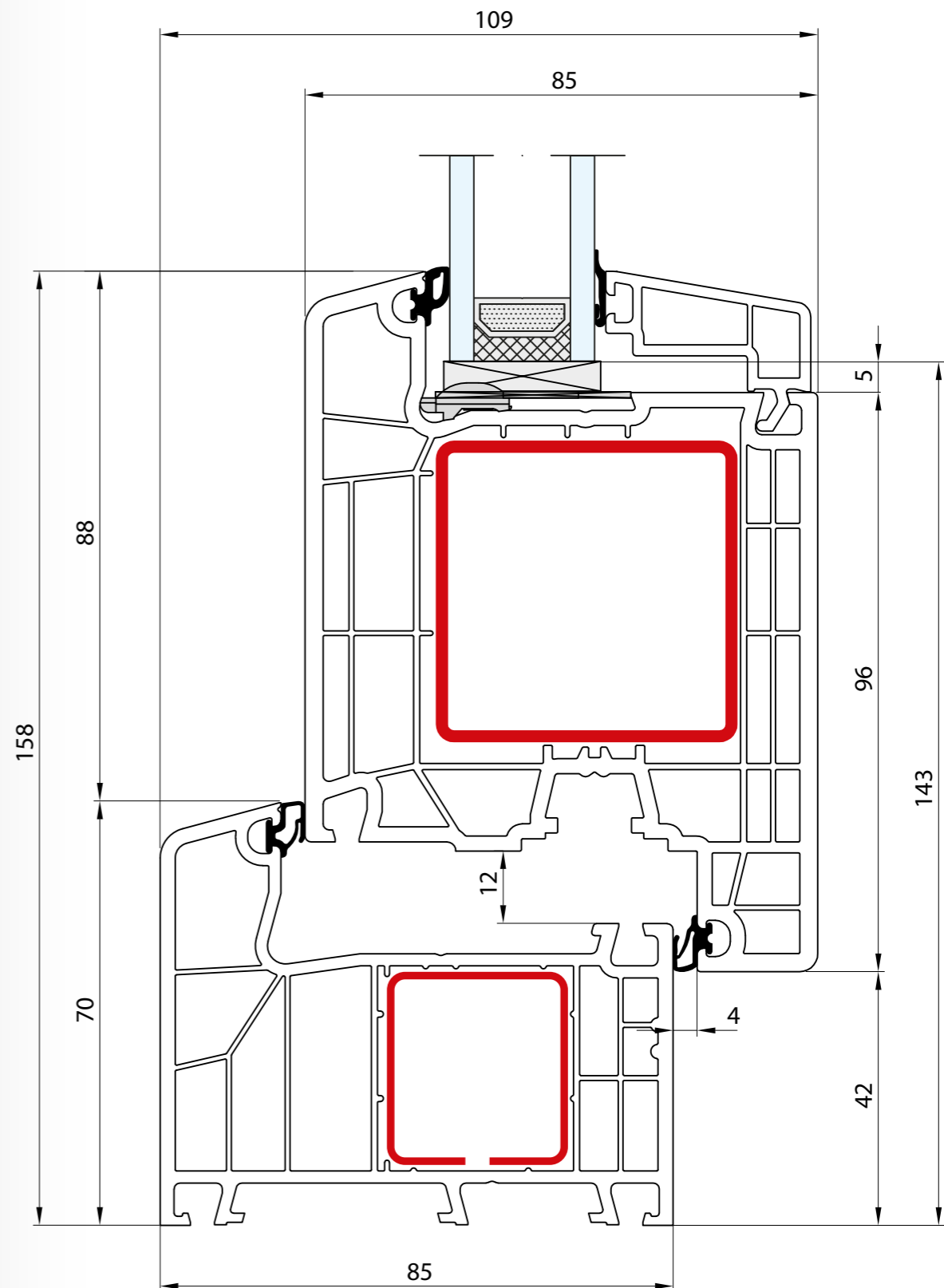
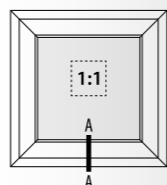

- Rama: 70 mm · Skrzydło: 116 mm
- Dormant: 70 mm · Vantail: 116 mm
- Frame: 70 mm · Sash: 116 mm
- Rahmen: 70 mm · Flügel: 116 mm
- Telaio: 70 mm · Anta: 116 mm

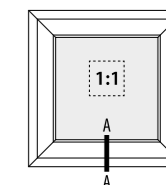

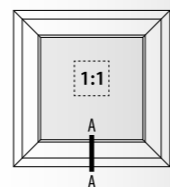
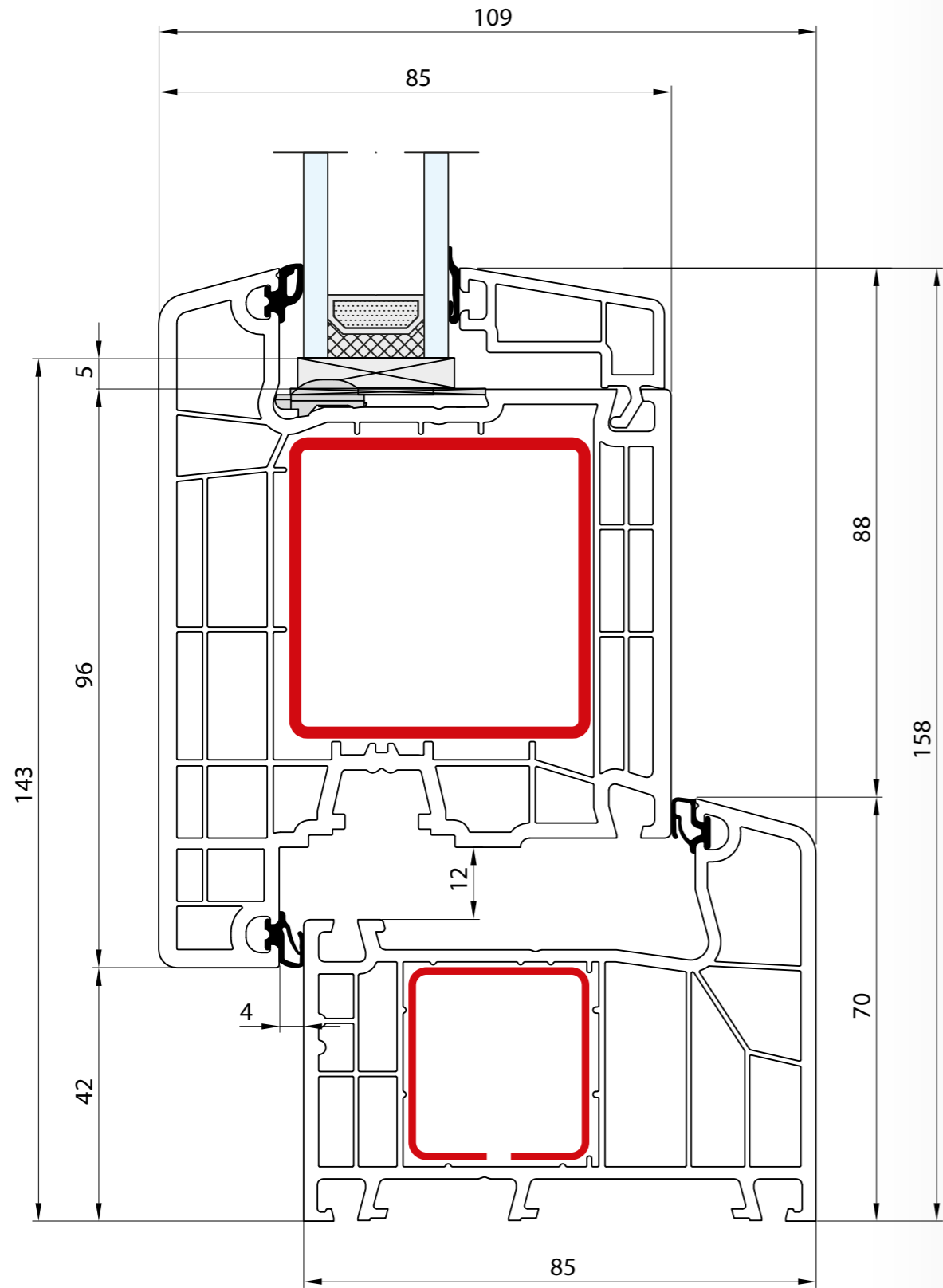

- Rama: 70 mm · Skrzydło: 116 mm
- Dormant: 70 mm · Vantail: 116 mm
- Frame: 70 mm · Sash: 116 mm
- Rahmen: 70 mm · Flügel: 116 mm
- Telaio: 70 mm · Anta: 116 mm

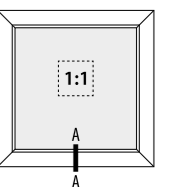
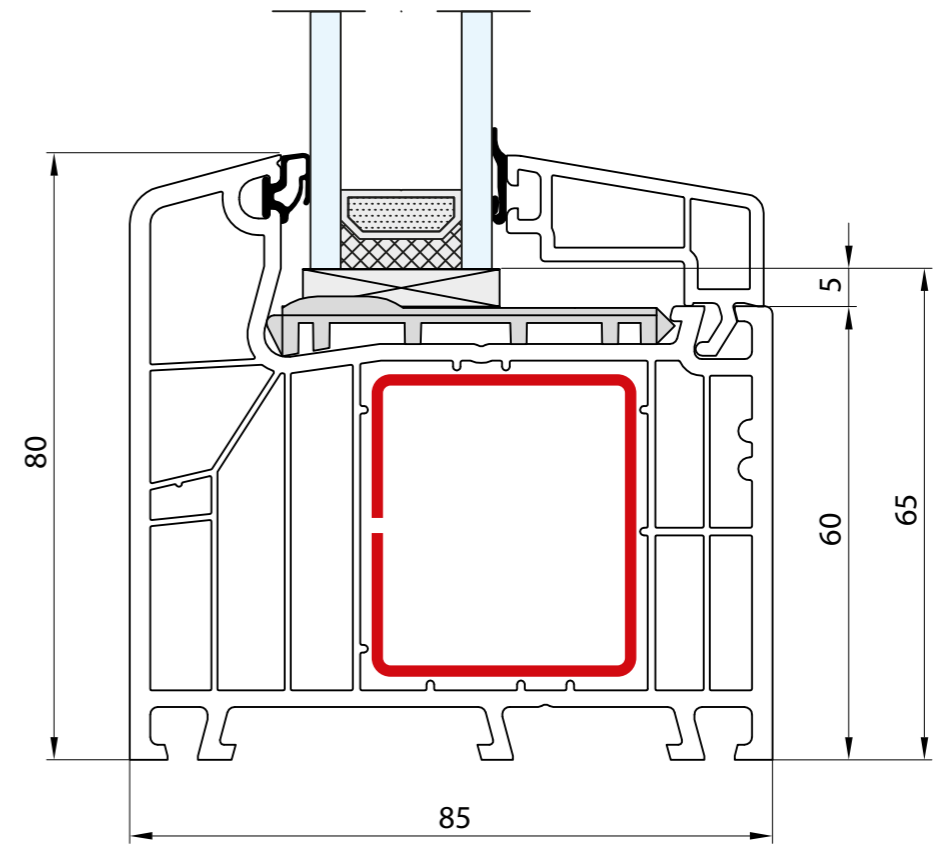

- Rama: 80 mm
- Dormant: 80 mm
- Frame: 80 mm
- Rahmen: 80 mm
- Telaio: 80 mm

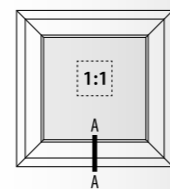
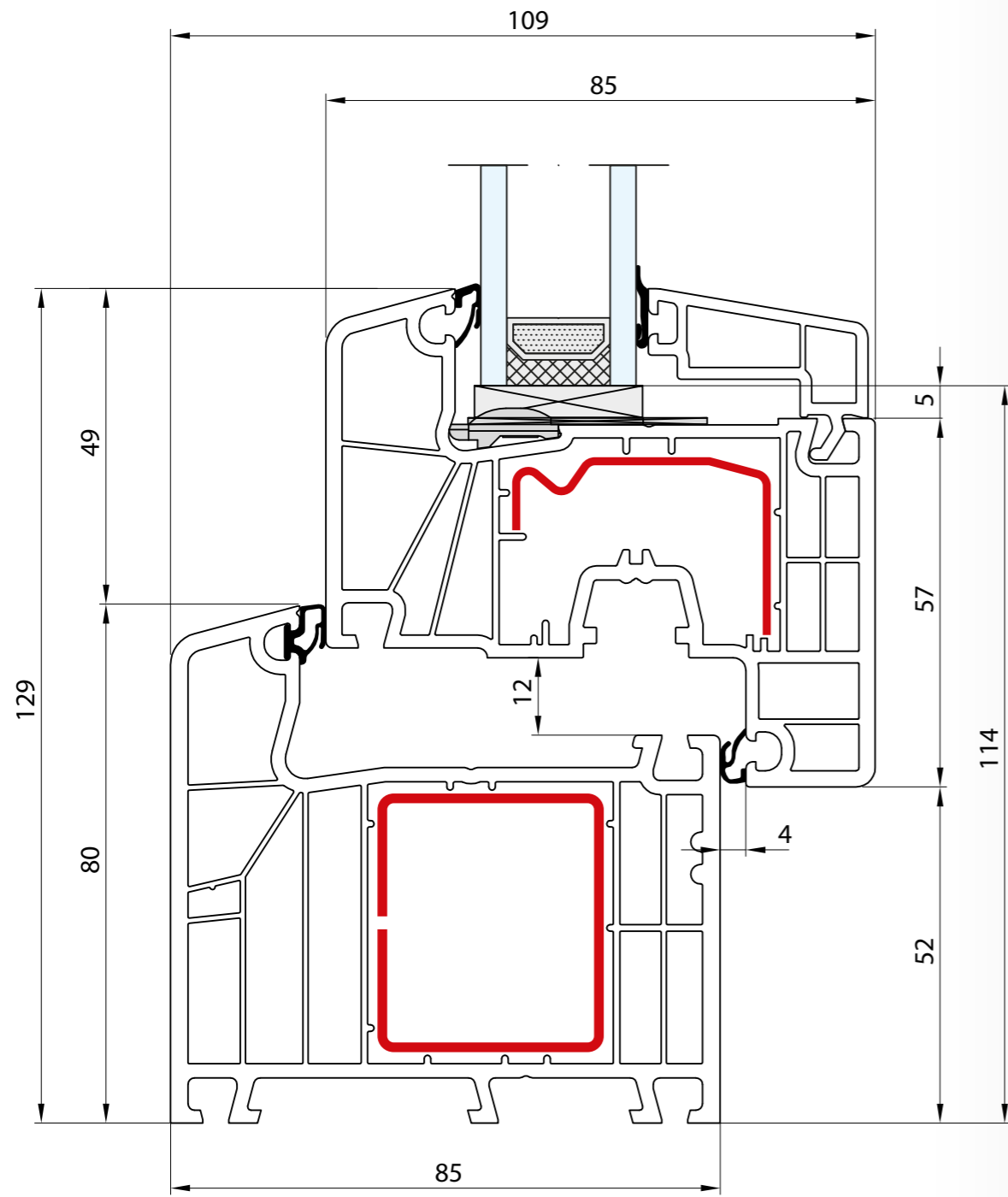

- Rama: 80 mm · Skrzydło: 77 mm
- Dormant: 80 mm · Vantail: 77 mm
- Frame: 80 mm · Sash: 77 mm
- Rahmen: 80 mm · Flügel: 77 mm
- Telaio: 80 mm · Anta: 77 mm

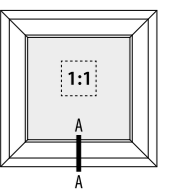
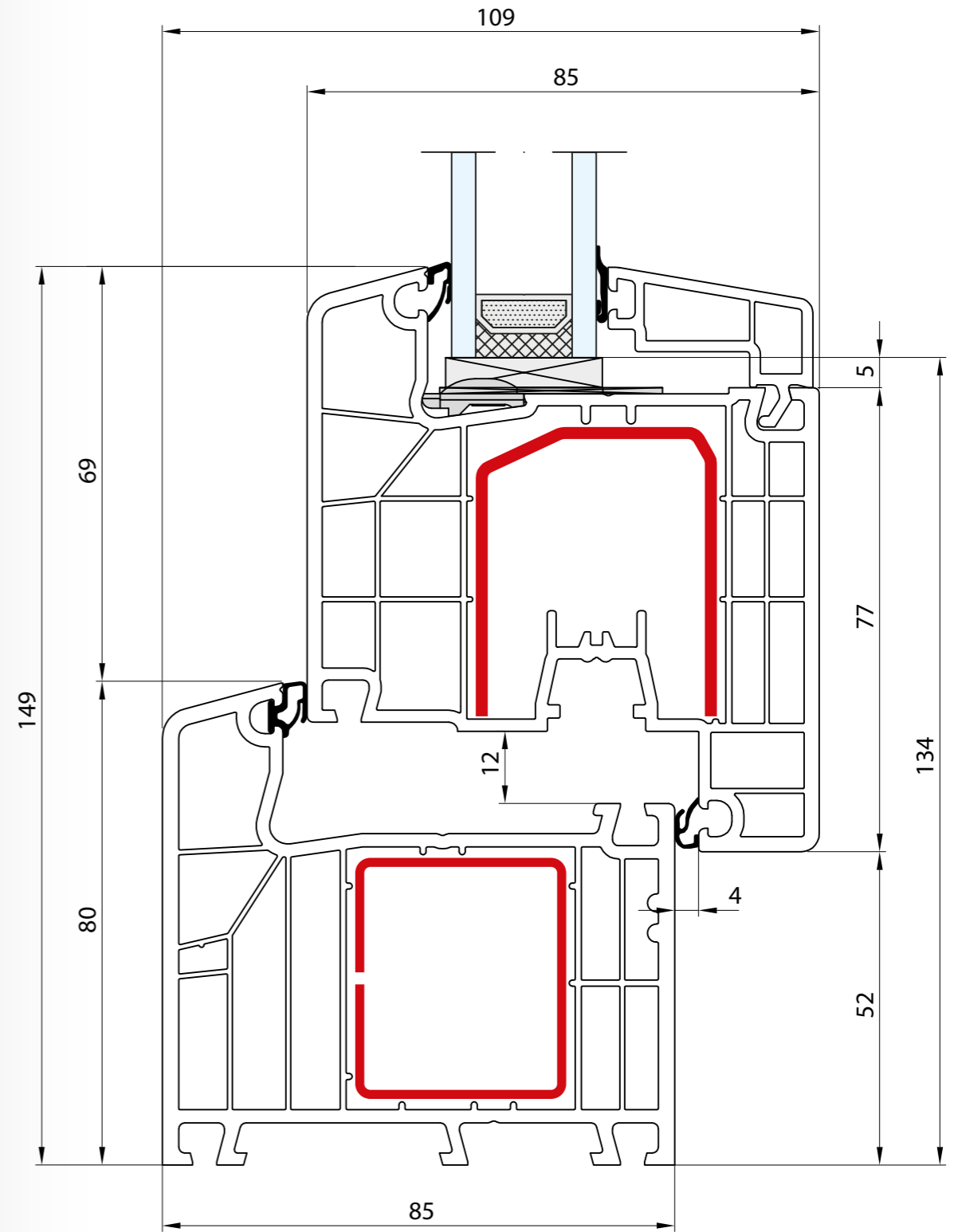

- Rama: 80 mm · Skrzydło: 97 mm
- Dormant: 80 mm · Vantail: 97 mm
- Frame: 80 mm · Sash: 97 mm
- Rahmen: 80 mm · Flügel: 97 mm
- Telaio: 80 mm · Anta: 97 mm

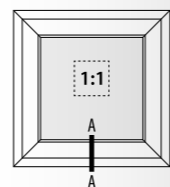
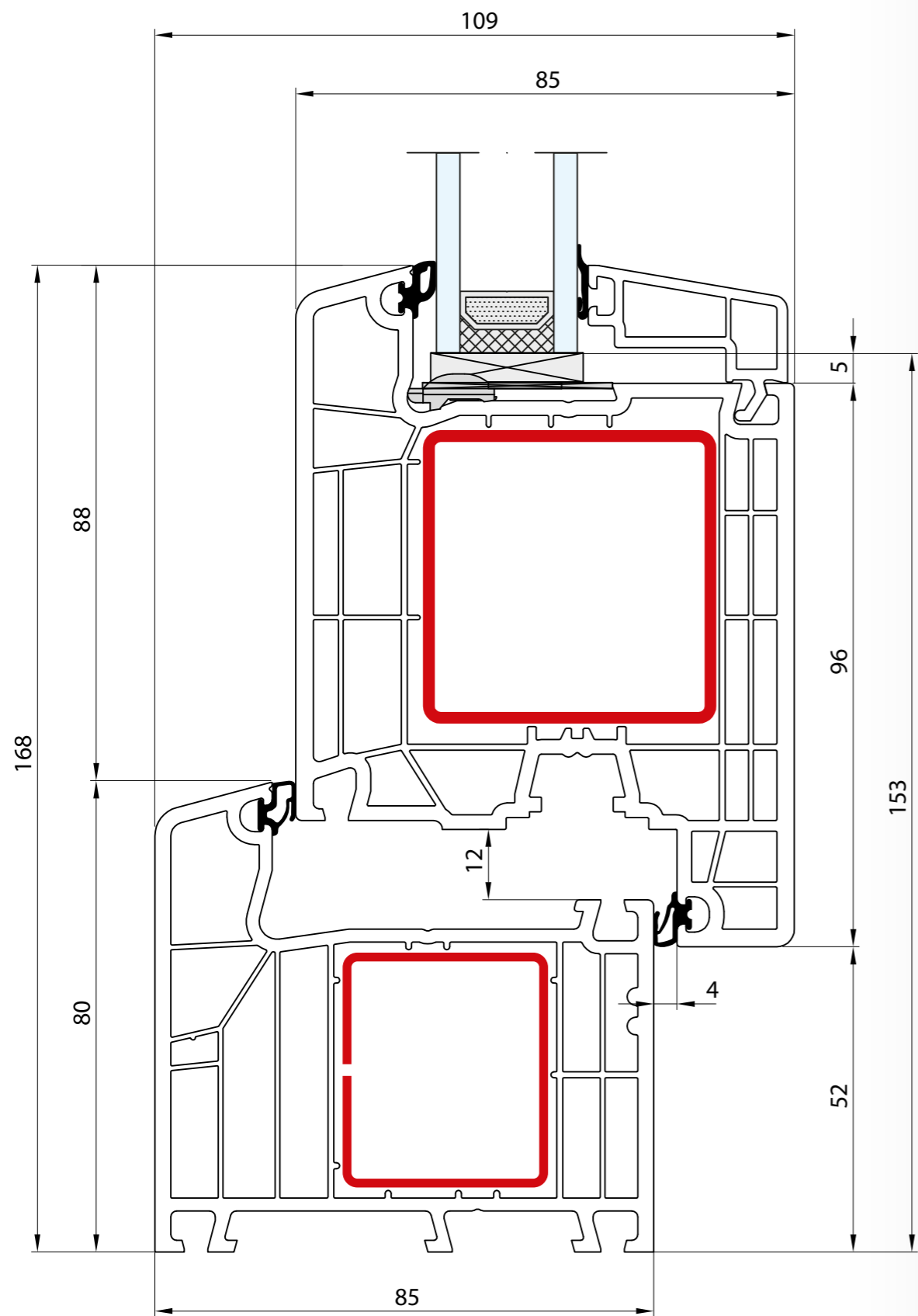

- Rama: 80 mm · Skrzydło: 116 mm
- Dormant: 80 mm · Vantail: 116 mm
- Frame: 80 mm · Sash: 116 mm
- Rahmen: 80 mm · Flügel: 116 mm
- Telaio: 80 mm · Anta: 116 mm

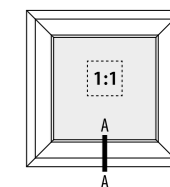
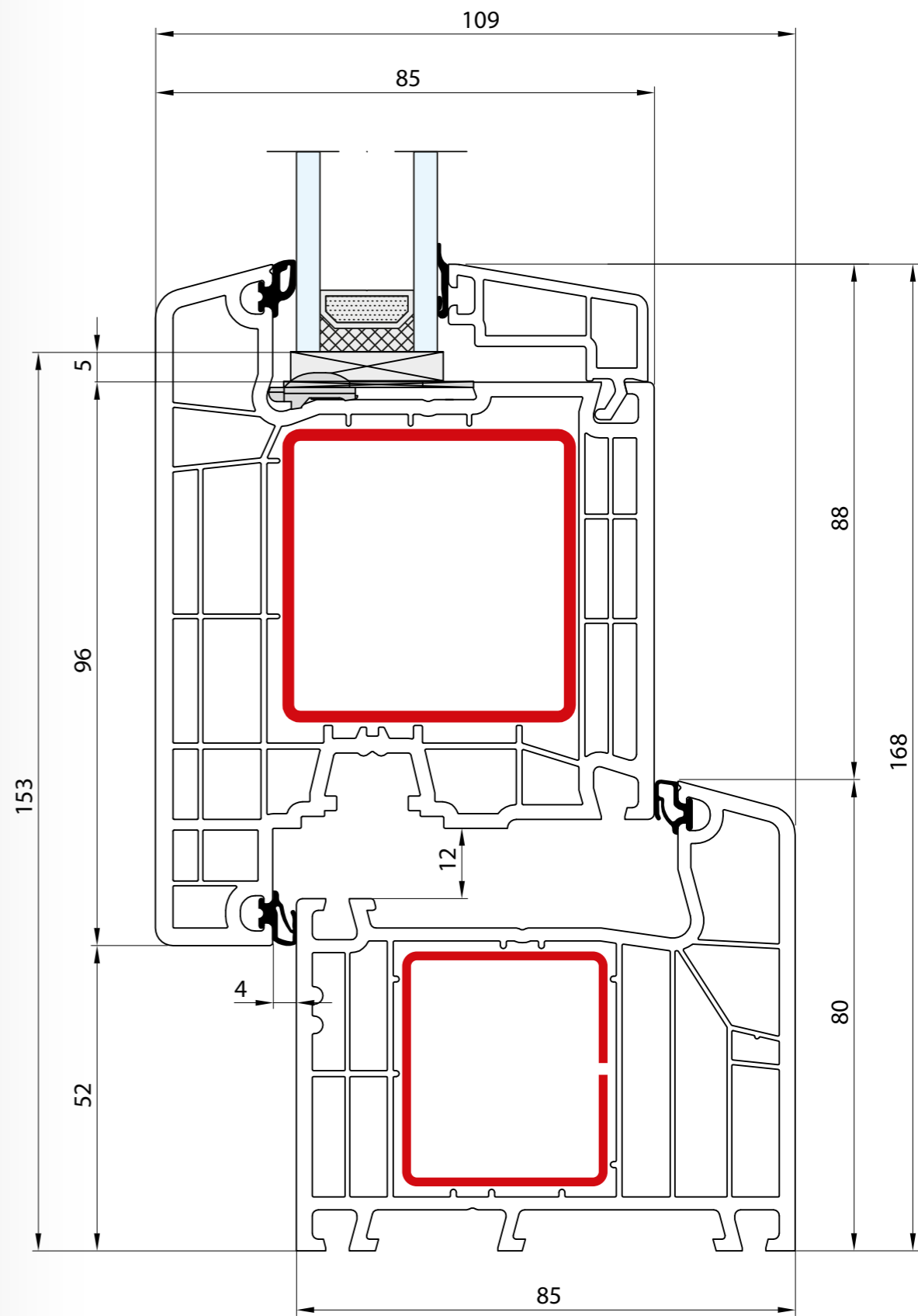

- Rama: 80 mm · Skrzydło: 116 mm
- Dormant: 80 mm · Vantail: 116 mm
- Frame: 80 mm · Sash: 116 mm
- Rahmen: 80 mm · Flügel: 116 mm
- Telaio: 80 mm · Anta: 116 mm

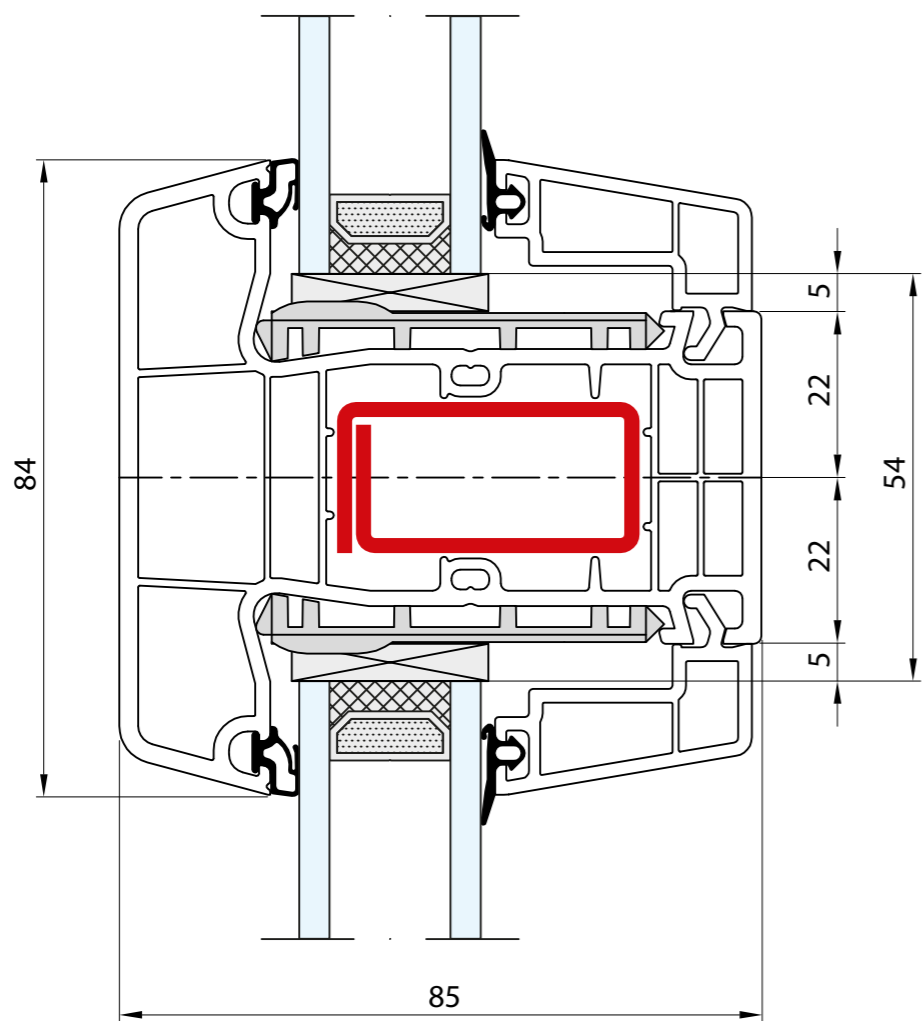

- Słupek stały: 84 mm
- Meneau fixe: 84 mm
- Fix post: 84 mm
- Festem Pfahl: 84 mm
- Montante fisso: 84 mm

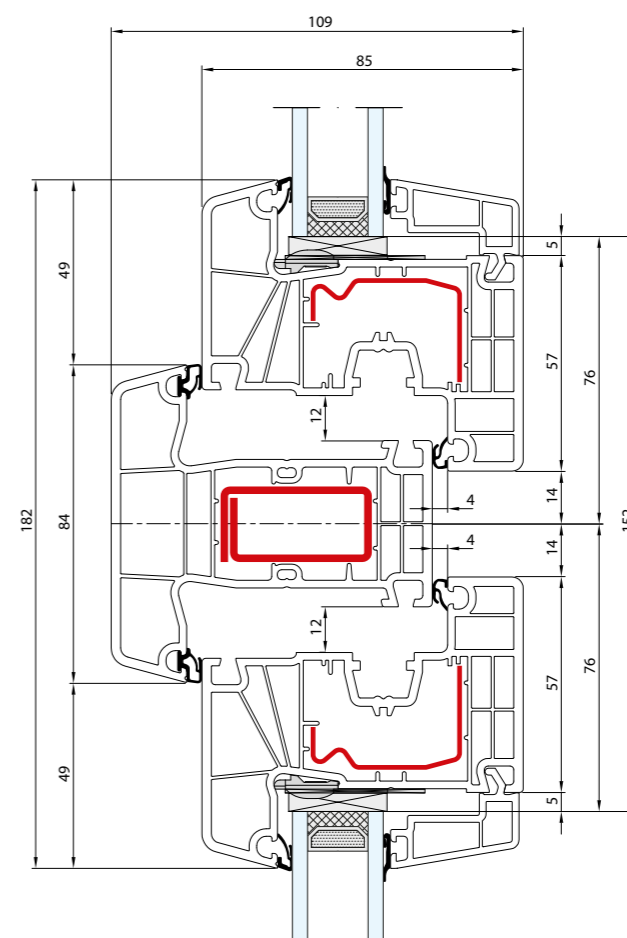
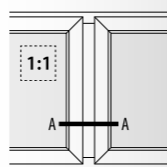

- Słupek stały: 84 mm · Skrzydło: 77 mm
- Meneau fixe: 84 mm · Vantail: 77 mm
- Fix post: 84 mm · Sash: 77 mm
- Festem Pfahl: 84 mm · Flügel: 77 mm
- Montante fisso: 84 mm · Anta: 77 mm

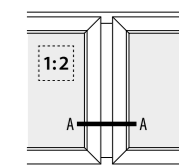

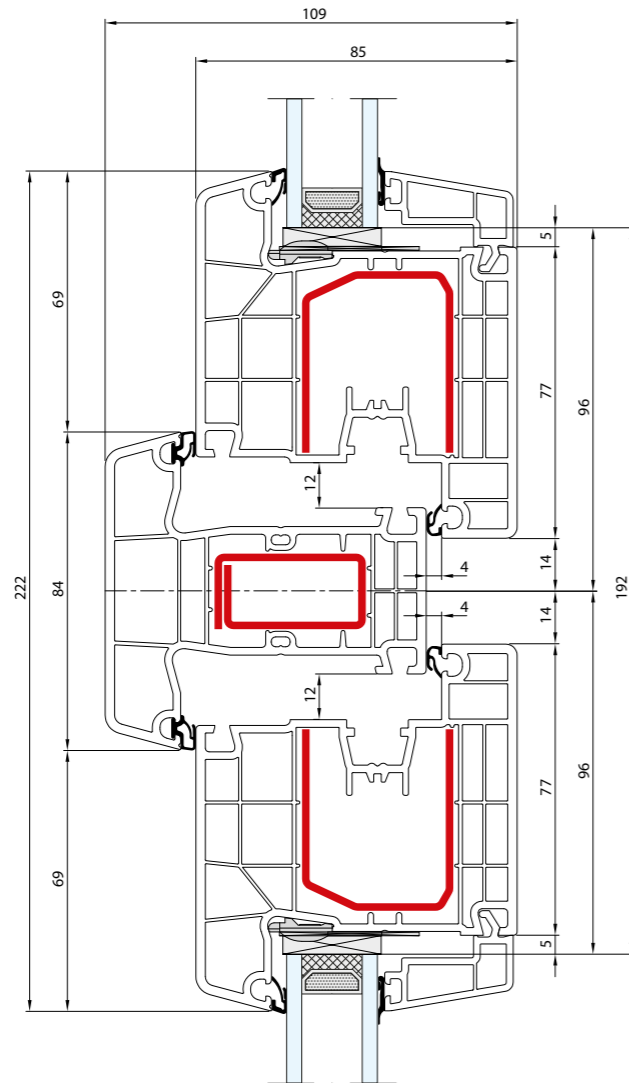

- Słupek stały: 84 mm · Skrzydło: 97 mm
- Meneau fixe: 84 mm · Vantail: 97 mm
- Fix post: 84 mm · Sash: 97 mm
- Festem Pfahl: 84 mm · Flügel: 97 mm
- Montante fisso: 84 mm · Anta: 97 mm

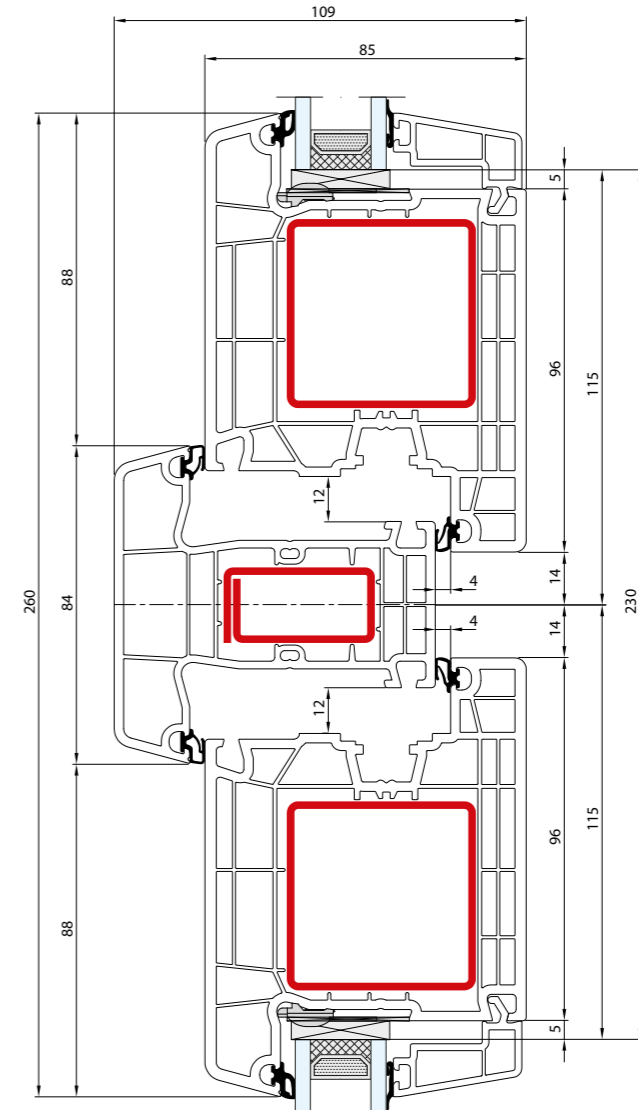
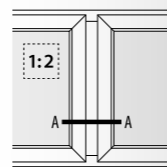

- Słupek stały: 84 mm · Skrzydło: 116 mm
- Meneau fixe: 84 mm · Vantail: 116 mm
- Fix post: 84 mm · Sash: 116 mm
- Festem Pfahl: 84 mm · Flügel: 116 mm
- Montante fisso: 84 mm · Anta: 116 mm

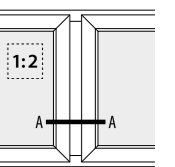

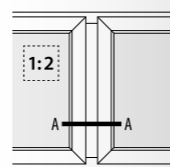
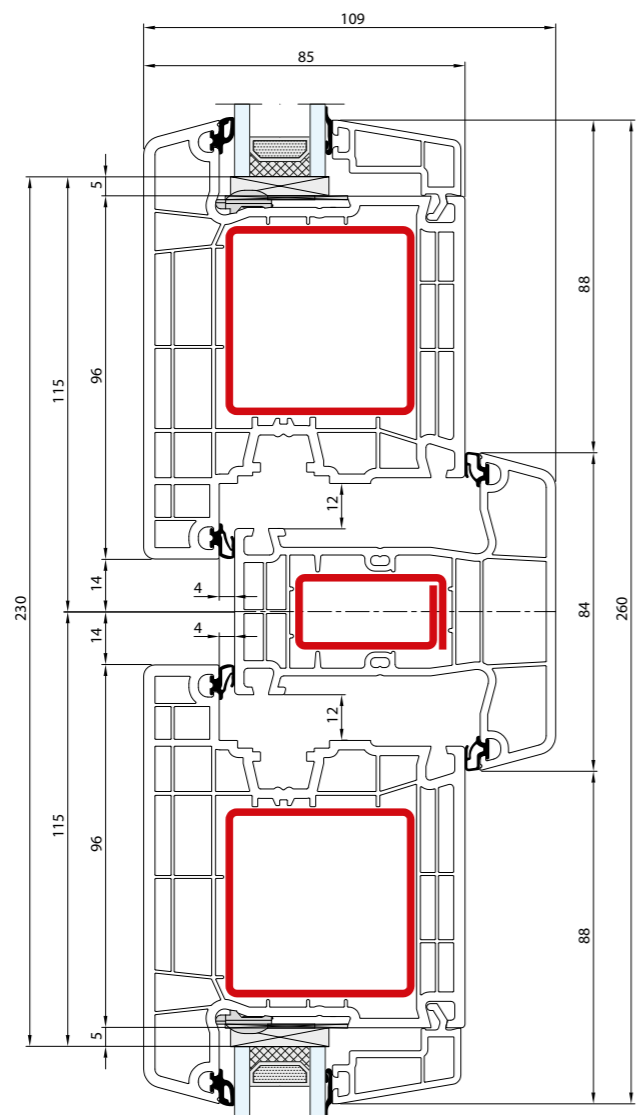

- Słupek stały: 84 mm · Skrzydło: 116 mm
- Meneau fixe: 84 mm · Vantail: 116 mm
- Fix post: 84 mm · Sash: 116 mm
- Festem Pfahl: 84 mm · Flügel: 116 mm
- Montante fisso: 84 mm · Anta: 116 mm

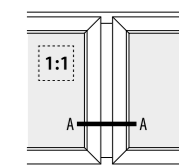
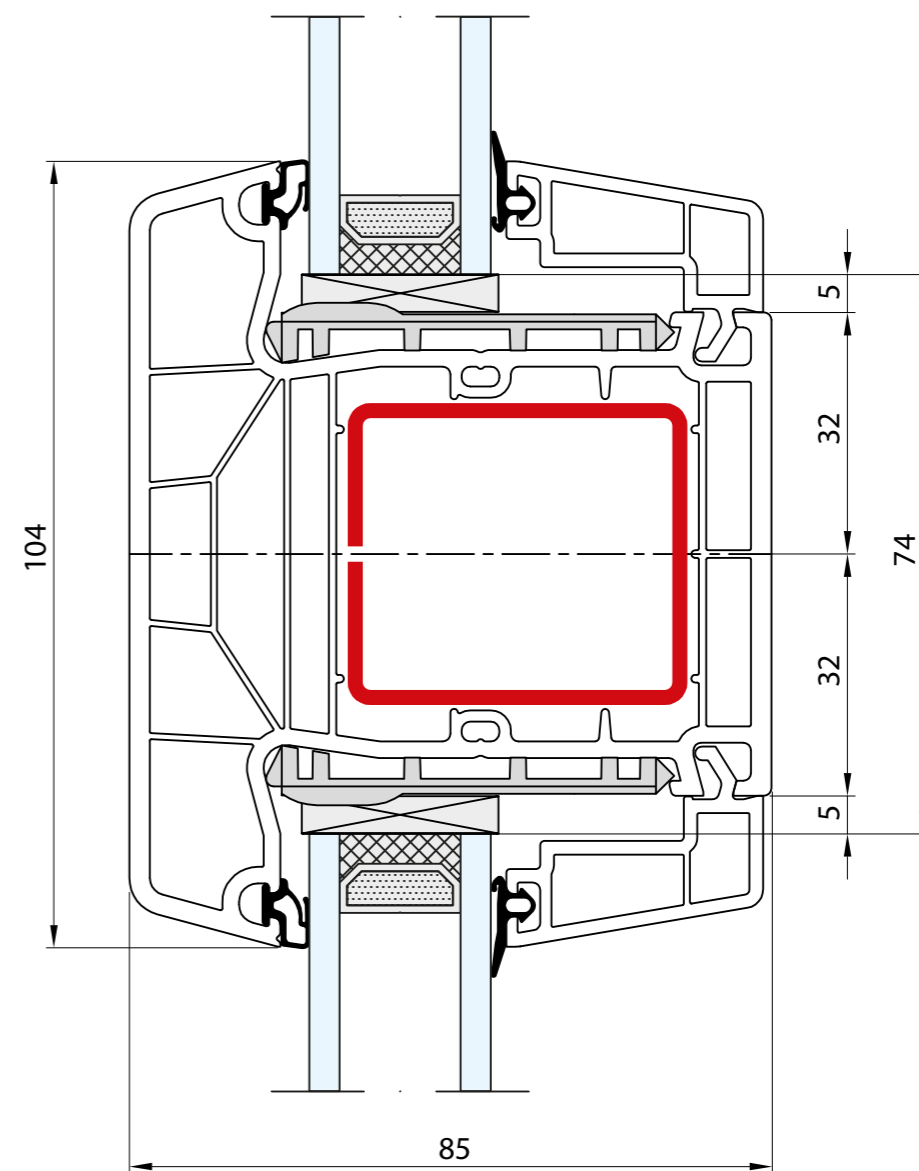

- Słupek stały: 104 mm
- Meneau fixe: 104 mm
- Fix post: 104 mm
- Festem Pfahl: 104 mm
- Montante fisso: 104 mm

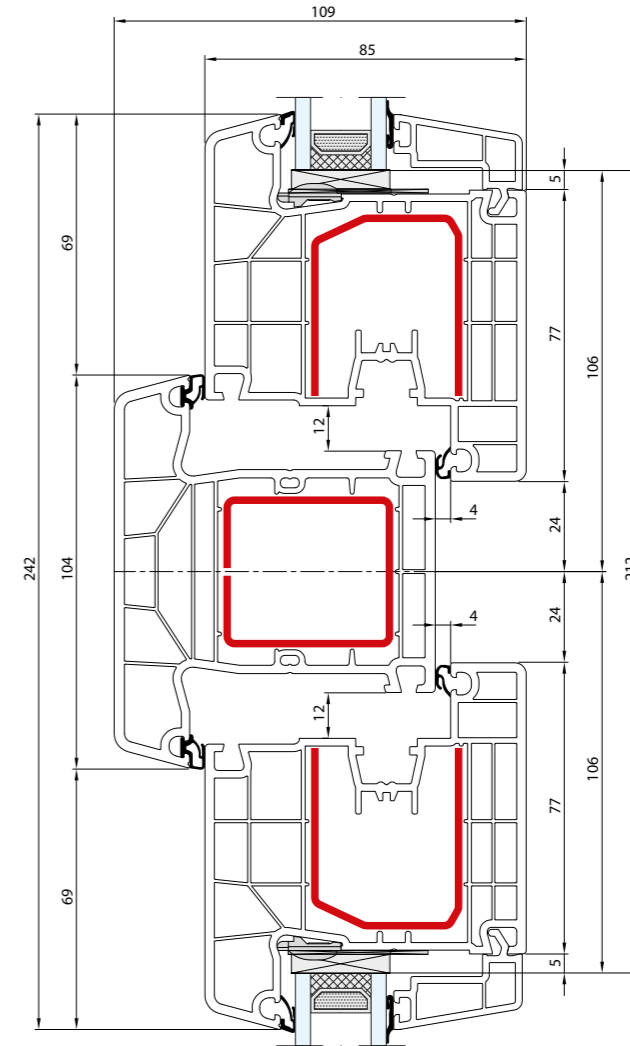
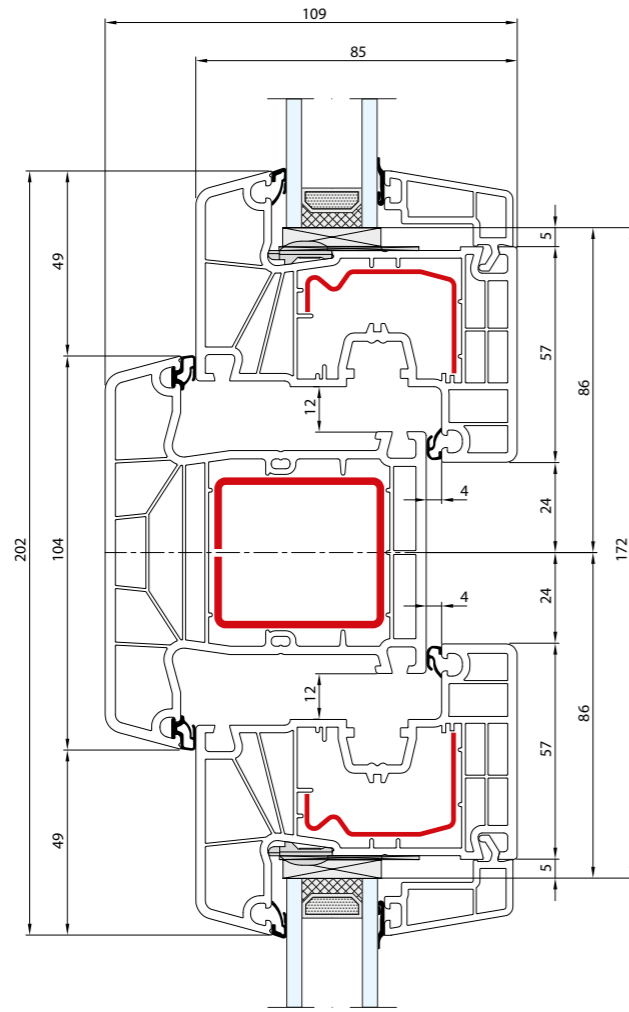

- Słupek stały: 104 mm · Skrzydło: 77 mm
- Meneau fixe: 104 mm · Vantail: 77 mm
- Fix post: 104 mm · Sash: 77 mm
- Festem Pfahl: 104 mm · Flügel: 77 mm
- Montante fisso: 104 mm · Anta: 77 mm

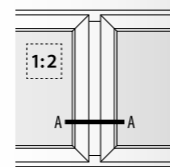

- Słupek stały: 104 mm · Skrzydło: 97 mm
- Meneau fixe: 104 mm · Vantail: 97 mm
- Fix post: 104 mm · Sash: 97 mm
- Festem Pfahl: 104 mm · Flügel: 97 mm
- Montante fisso: 104 mm · Anta: 97 mm

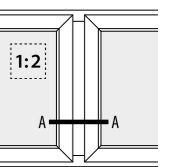

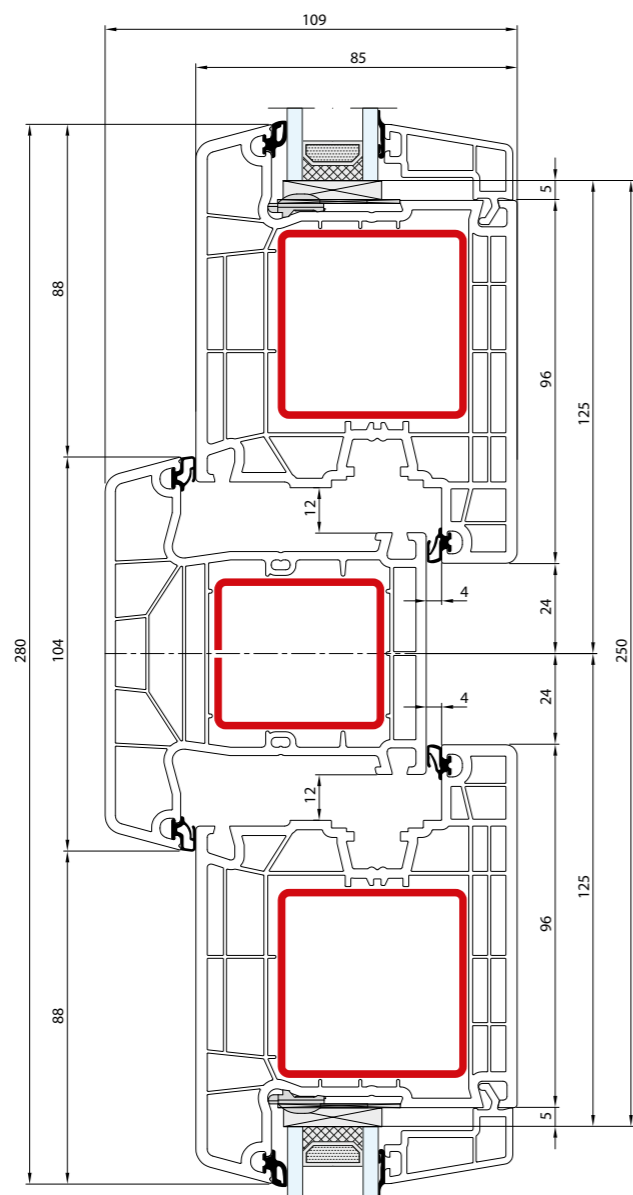

- Słupek stały: 104 mm · Skrzydło: 116 mm
- Meneau fixe: 104 mm · Vantail: 116 mm
- Fix post: 104 mm · Sash: 116 mm
- Festem Pfahl: 104 mm · Flügel: 116 mm
- Montante fisso: 104 mm · Anta: 116 mm

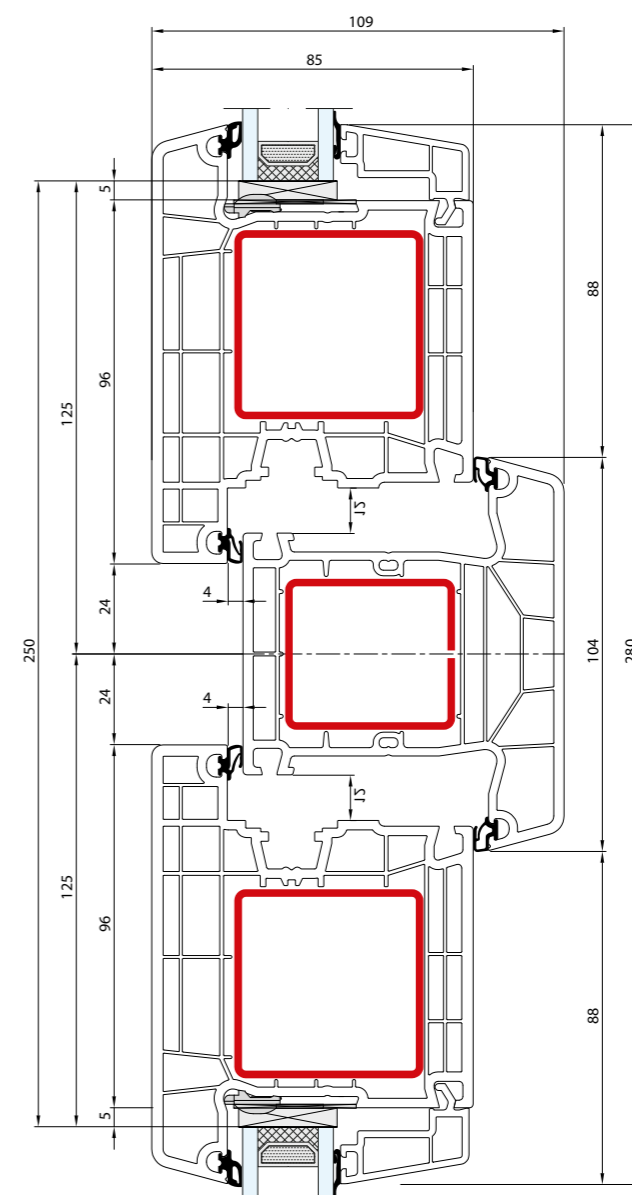
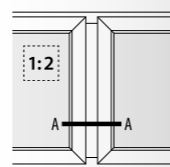

- Słupek stały: 104 mm · Skrzydło: 116 mm
- Meneau fixe: 104 mm · Vantail: 116 mm
- Fix post: 104 mm · Sash: 116 mm
- Festem Pfahl: 104 mm · Flügel: 116 mm
- Montante fisso: 104 mm · Anta: 116 mm

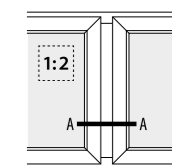

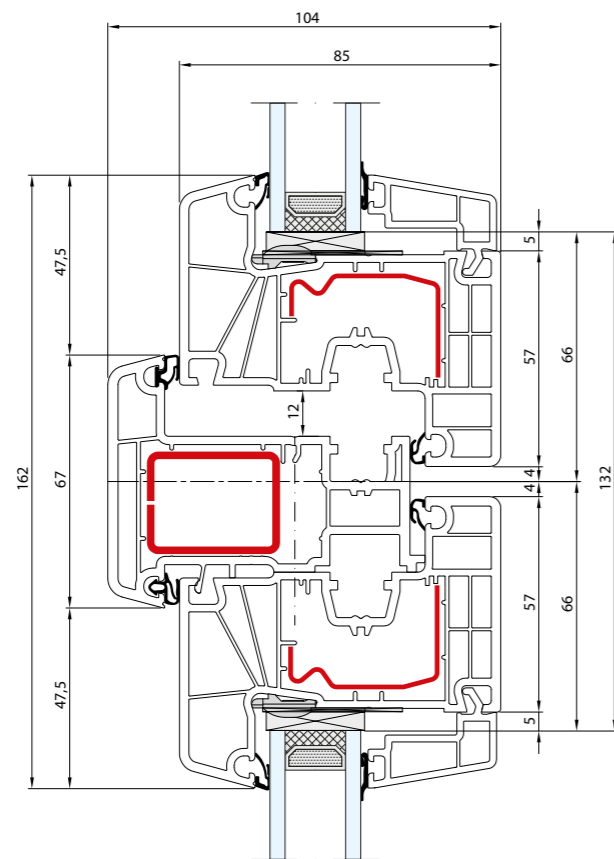

- Słupek ruchomy: 67 mm · Skrzydło: 77 mm
- Meneau mobile: 67 mm · Vantail: 77 mm
- Movable post: 67 mm · Sash: 77 mm
- Stulp: 67 mm · Flügel: 77 mm
- Montante mobile: 67 mm · Anta: 77 mm

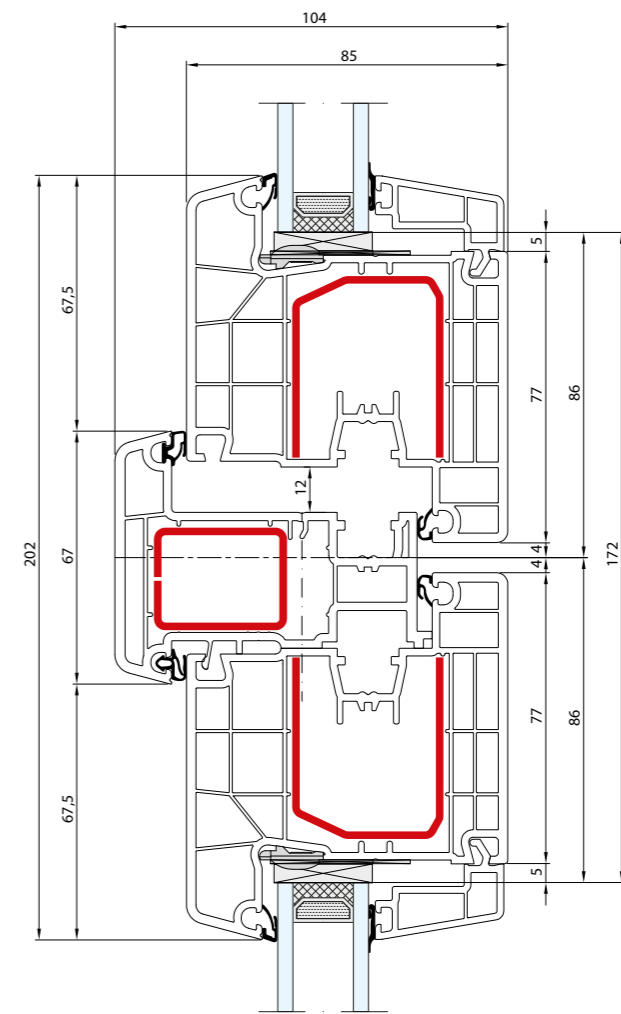
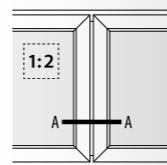

- Słupek ruchomy: 67 mm · Skrzydło: 97 mm
- Meneau mobile: 67 mm · Vantail: 97 mm
- Movable post: 67 mm · Sash: 97 mm
- Stulp: 67 mm · Flügel: 97 mm
- Montante mobile: 67 mm · Anta: 97 mm

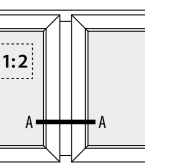

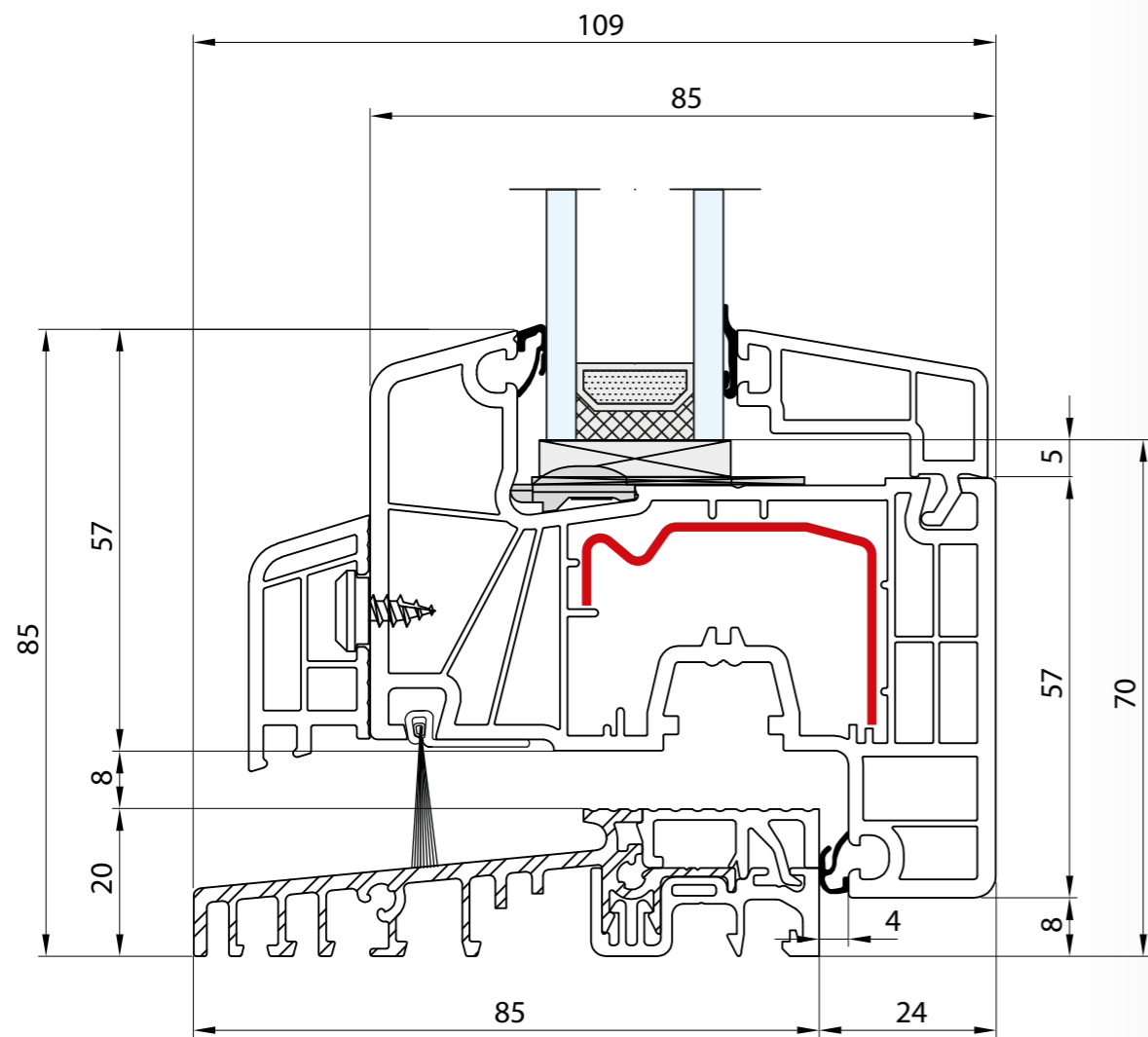

- Próg: 20 mm · Skrzydło: 77 mm
- Seuil: 20 mm · Vantail: 77 mm
- Threshold: 20 mm · Sash: 77 mm
- Schwelle: 20 mm · Flügel: 77 mm
- Soglia: 20 mm · Anta: 77 mm

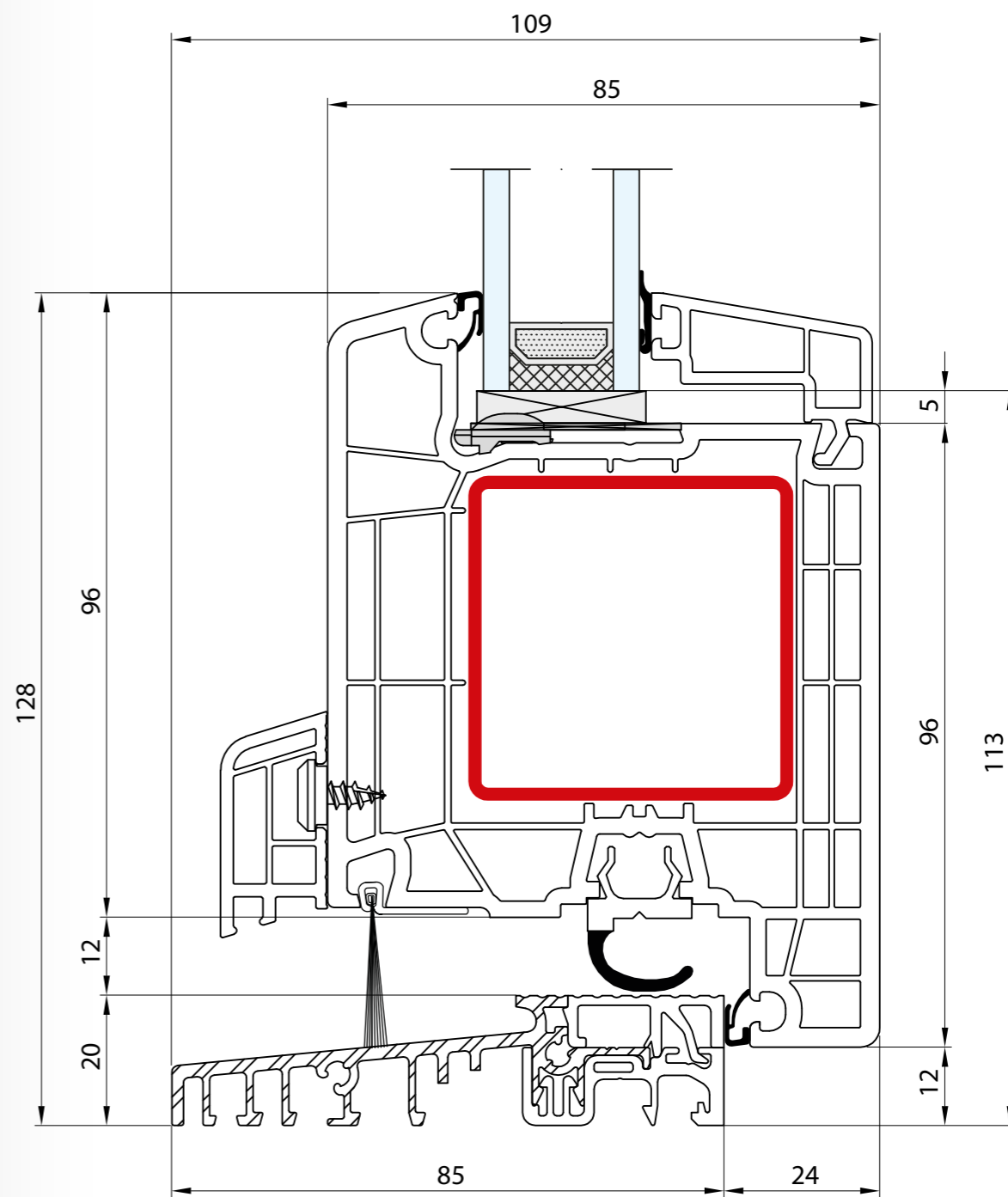
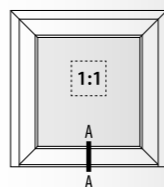

- Próg: 20 mm · Skrzydło: 116 mm
- Seuil: 20 mm · Vantail: 116 mm
- Threshold: 20 mm · Sash: 116 mm
- Schwelle: 20 mm · Flügel: 116 mm
- Soglia: 20 mm · Anta: 116 mm

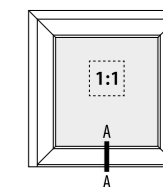

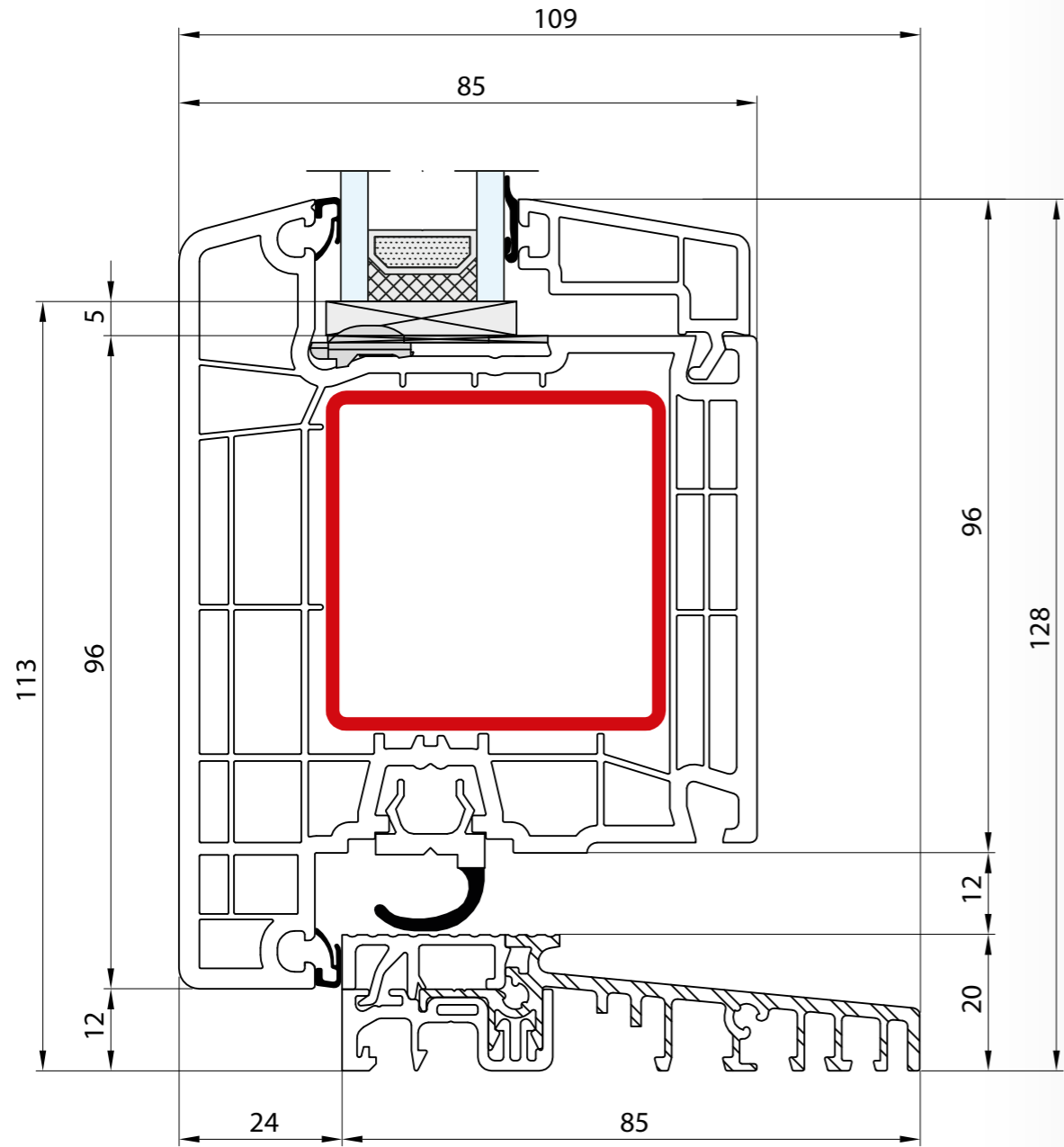

- Próg: 20 mm · Skrzydło: 116 mm
- Seuil: 20 mm · Vantail: 116 mm
- Threshold: 20 mm · Sash: 116 mm
- Schwelle: 20 mm · Flügel: 116 mm
- Soglia: 20 mm · Anta: 116 mm

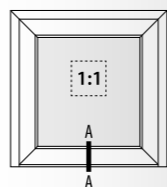

IDEAL 8000

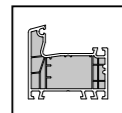
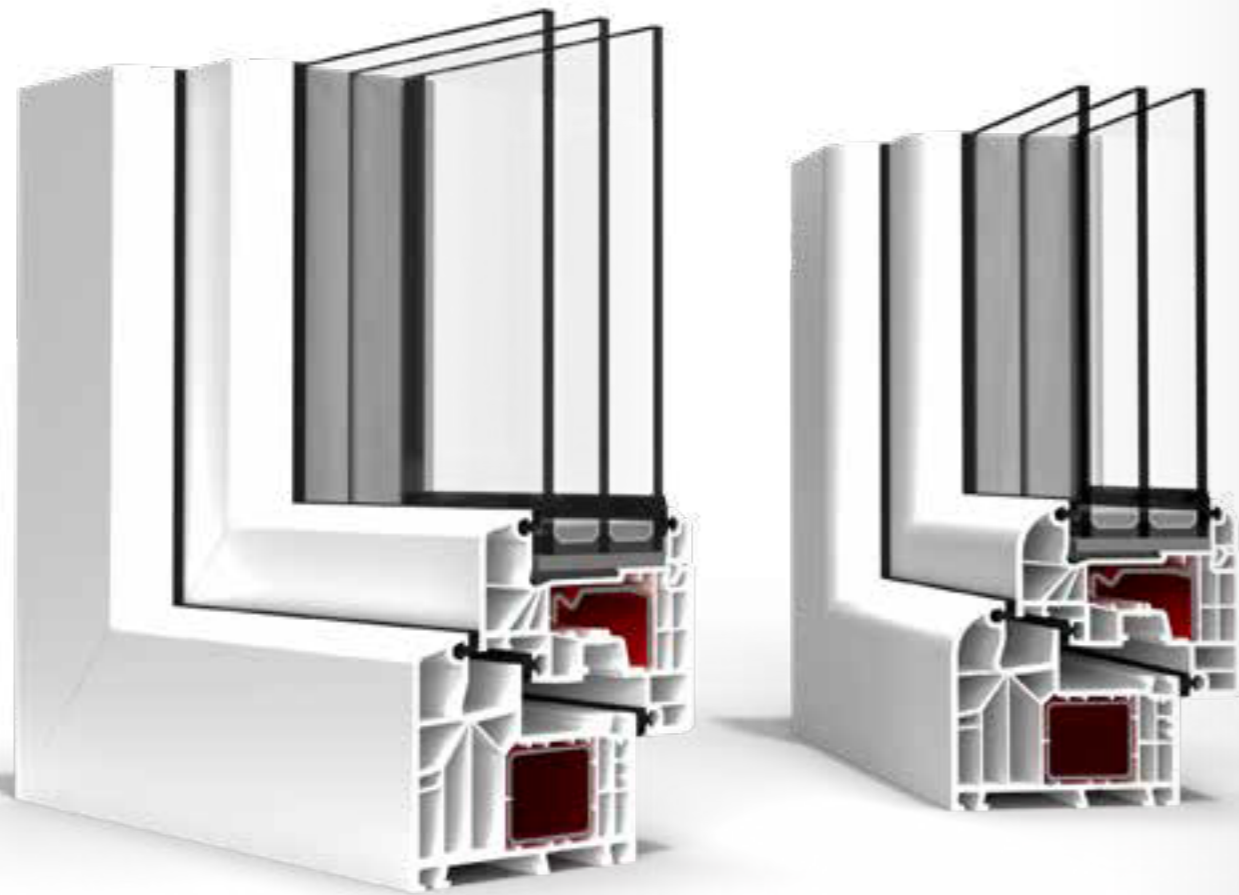

6



3

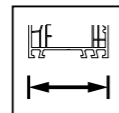

85

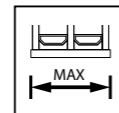

52

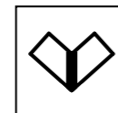

V-PERFECT TECHNOLOGY



ALU

IDEAL 4000

IDEAL 0000 NEW

IDEAL 5000

IDEAL 7000 NEW

IDEAL 8000

ENERGETO 8000

IDEAL 4000

IDEAL 0000 NEW

IDEAL 5000

IDEAL 7000 NEW

IDEAL 8000

ENERGETO 8000

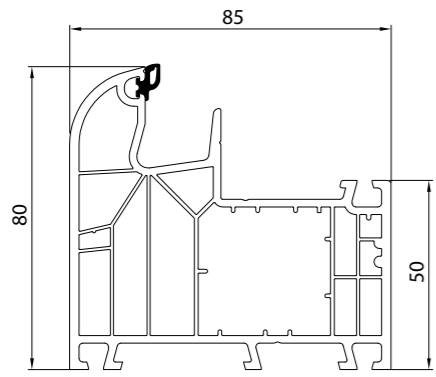

RL 180x03

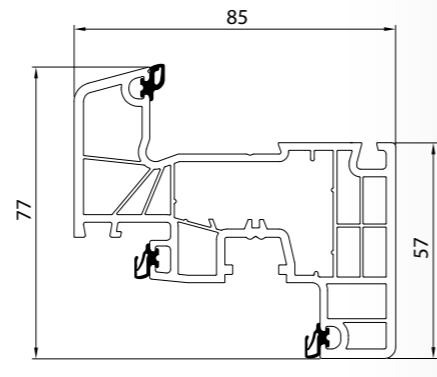

CL 180x20

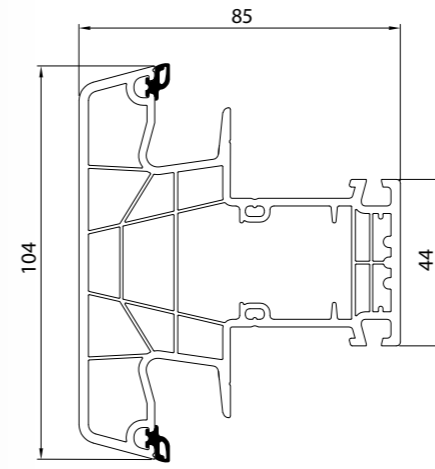

CL ALU 180x44

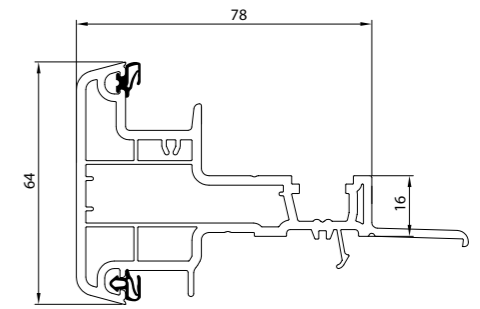

CL ALU 180x64

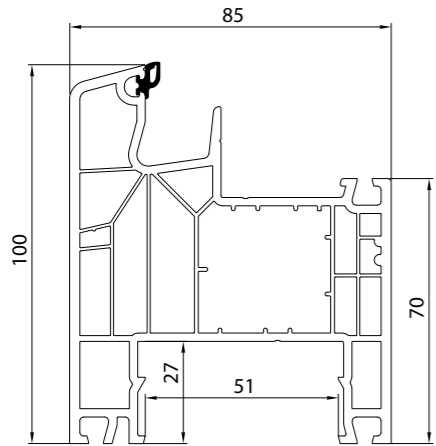

CL ALU 180x04

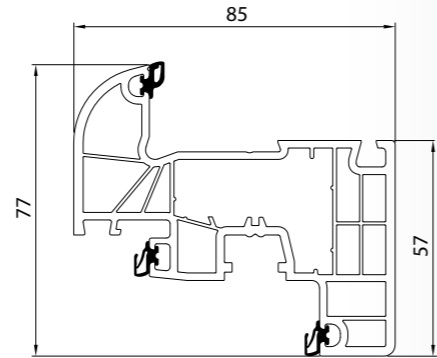

CL 180x22

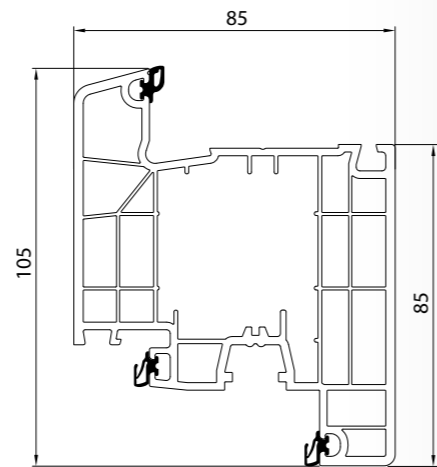

CL ALU 180x30

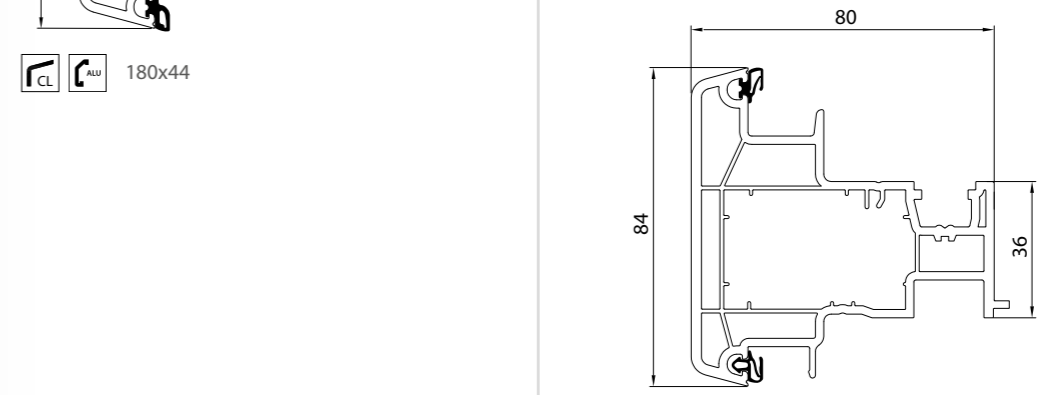

CL ALU 180x66

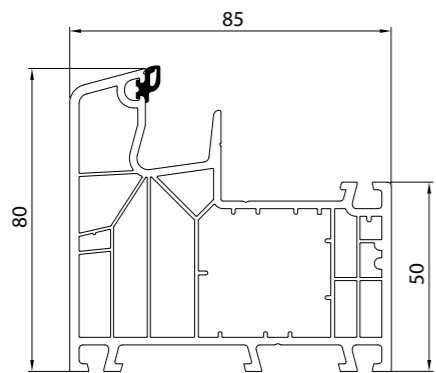

CL ALU 180x05

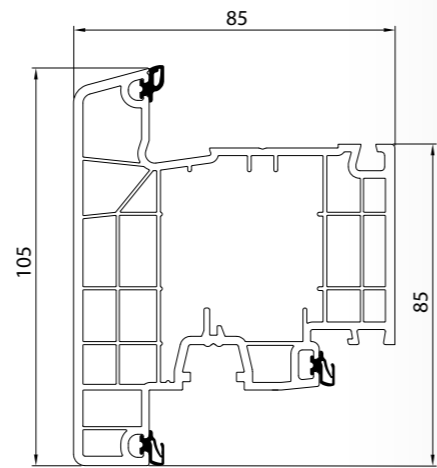

CL 180x31

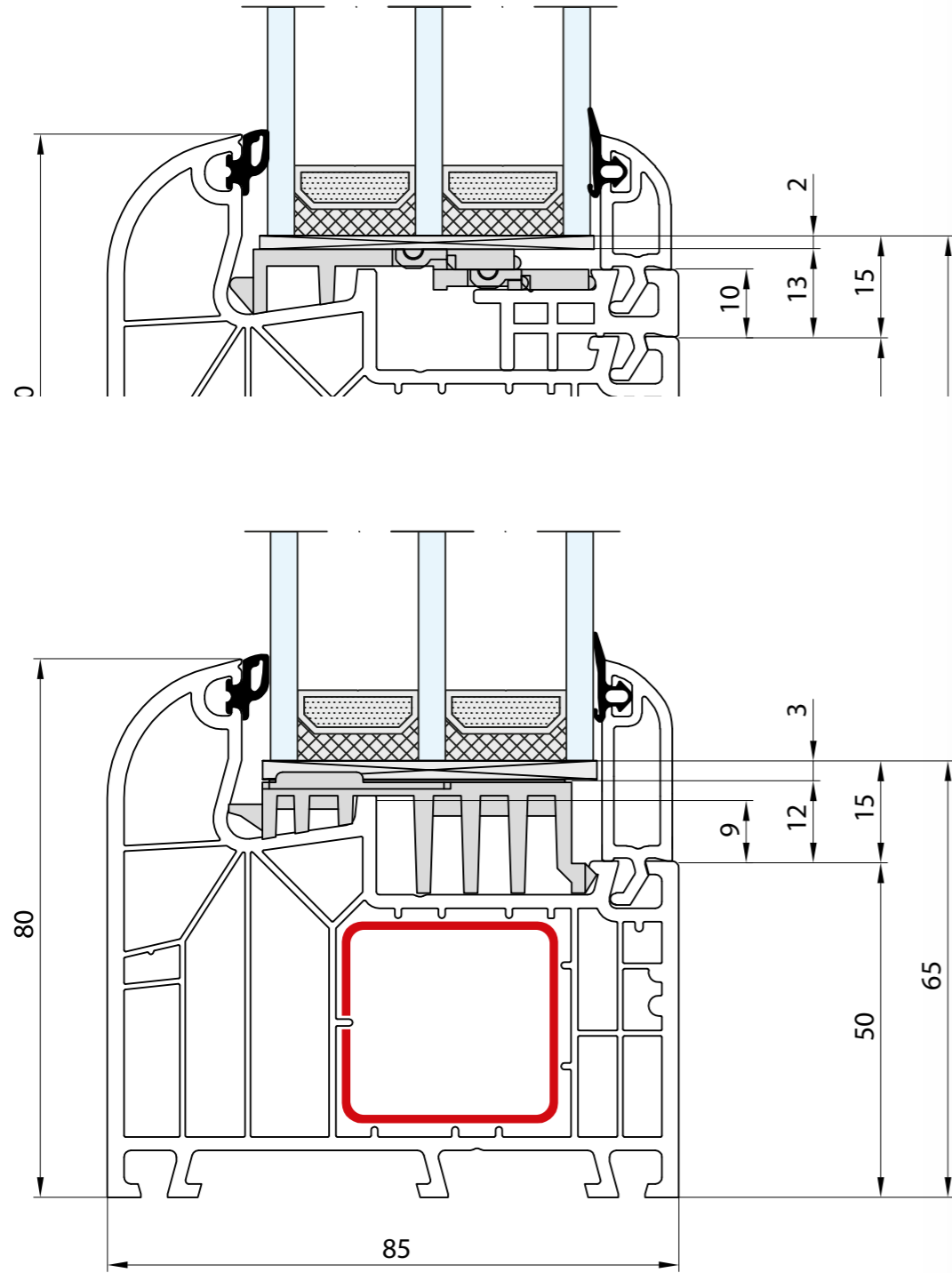

- Rama: 80 mm
- Dormant: 80 mm
- Frame: 80 mm
- Rahmen: 80 mm
- Telaio: 80 mm

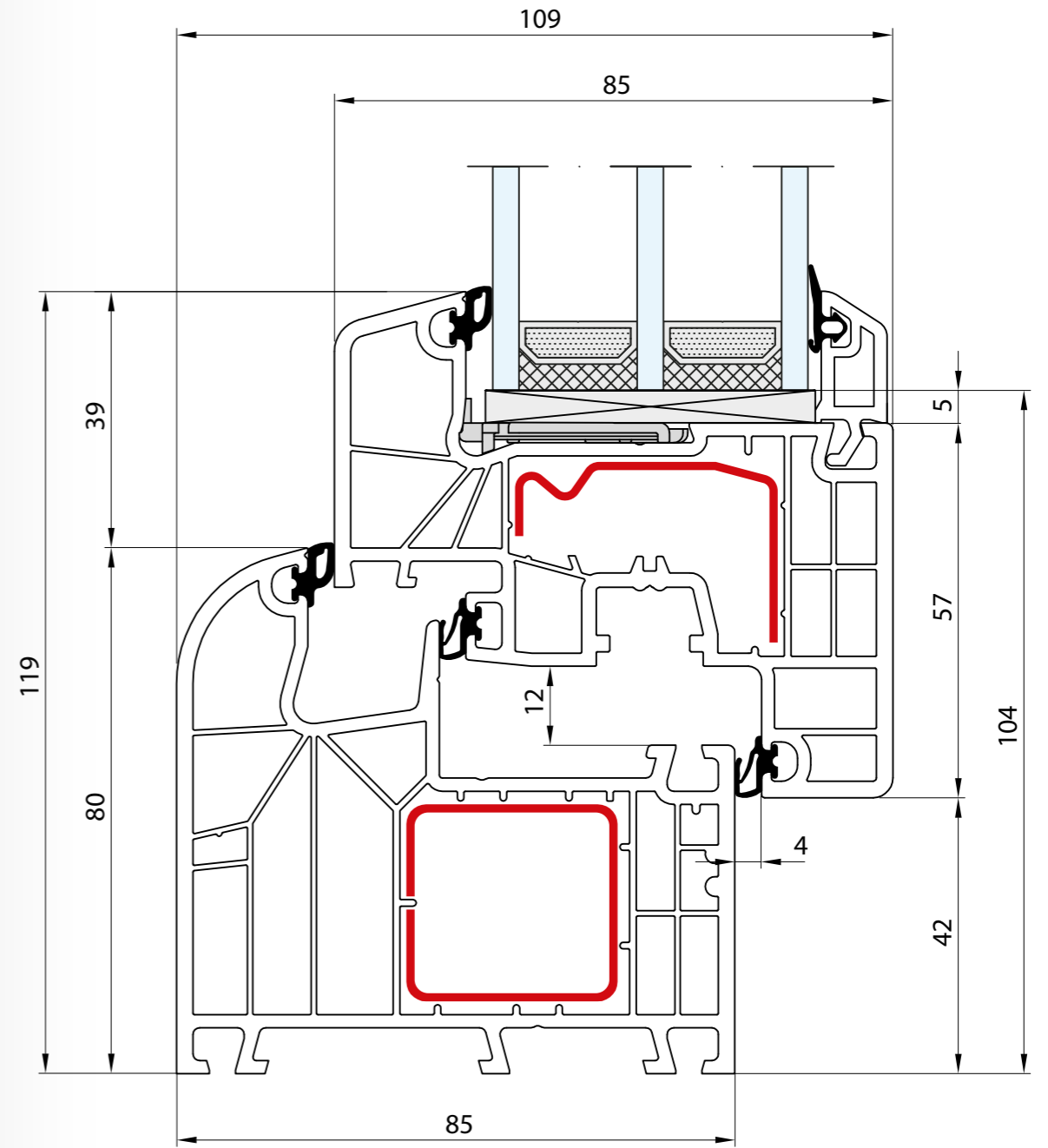
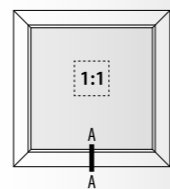

- Rama: 80 mm · Skrzydło: 77 mm
- Dormant: 80 mm · Vantail: 77 mm
- Frame: 80 mm · Sash: 77 mm
- Rahmen: 80 mm · Flügel: 77 mm
- Telaio: 80 mm · Anta: 77 mm

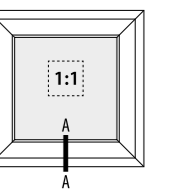

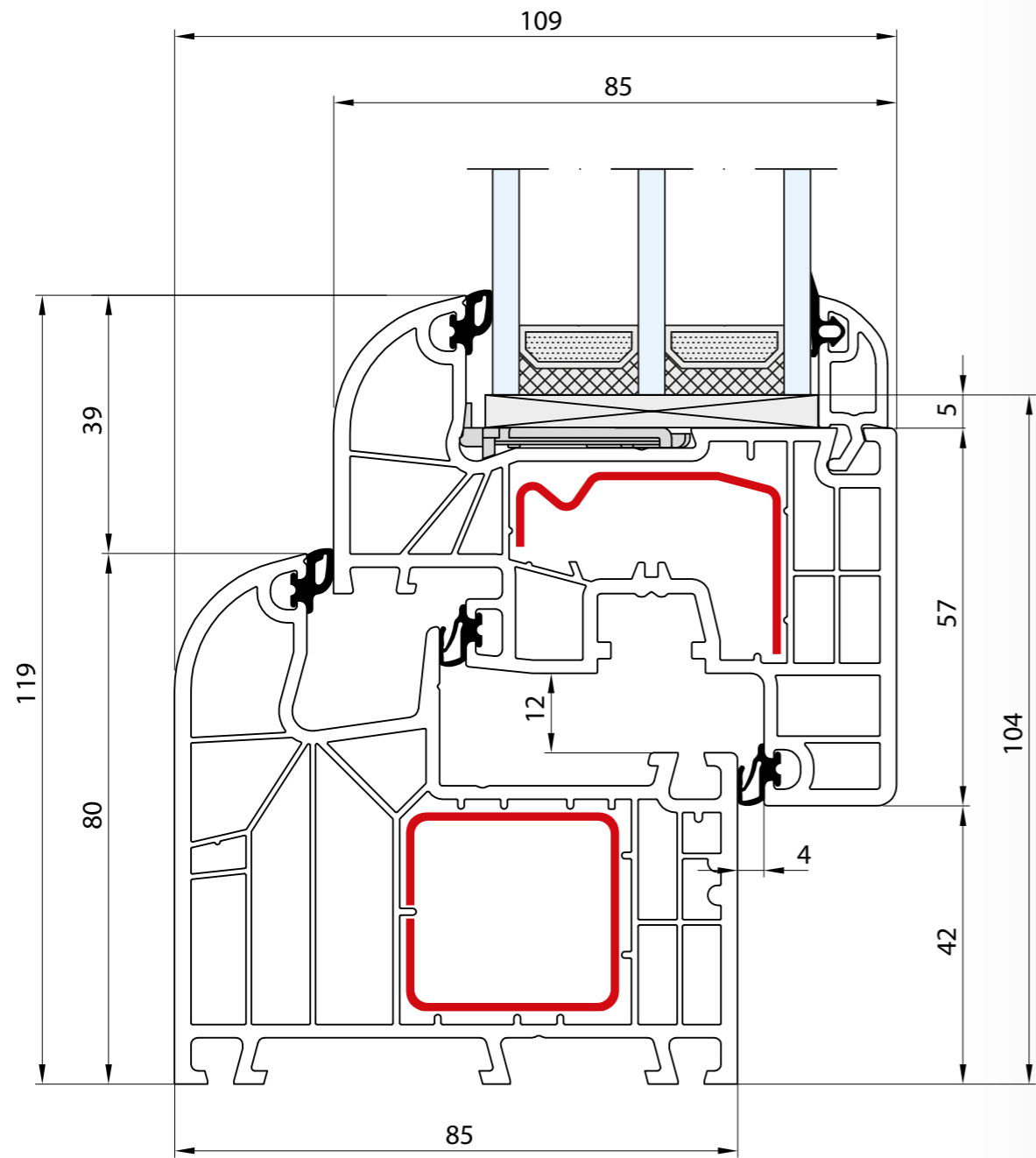

- Rama: 80 mm · Skrzydło: 77 mm
- Dormant: 80 mm · Vantail: 77 mm
- Frame: 80 mm · Sash: 77 mm
- Rahmen: 80 mm · Flügel: 77 mm
- Telaio: 80 mm · Anta: 77 mm

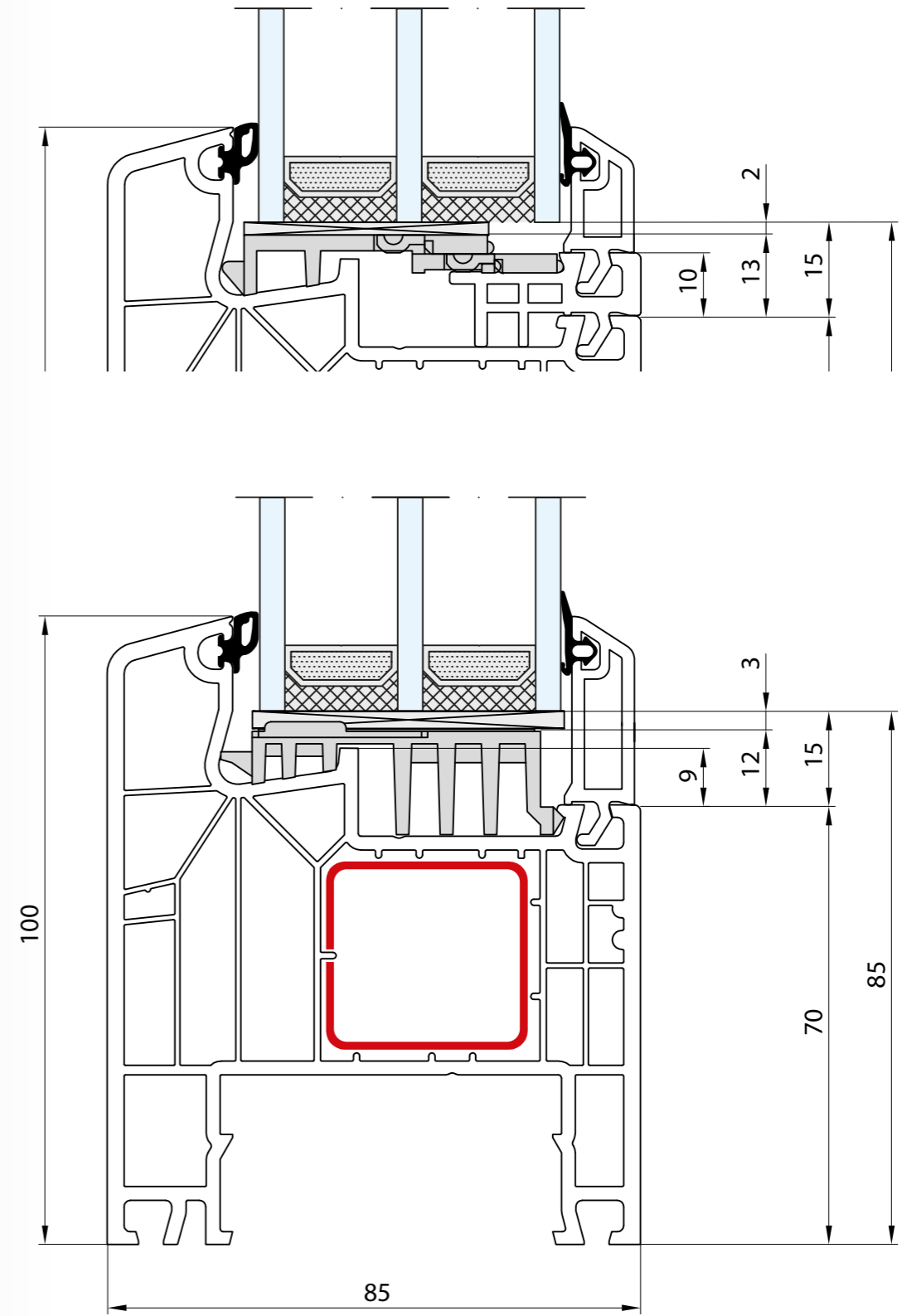
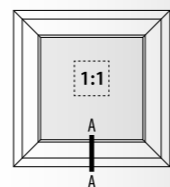

- Rama: 100 mm
- Dormant: 100 mm
- Frame: 100 mm
- Rahmen: 100 mm
- Telaio: 100 mm

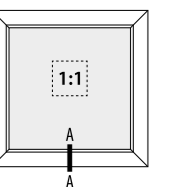

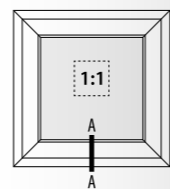
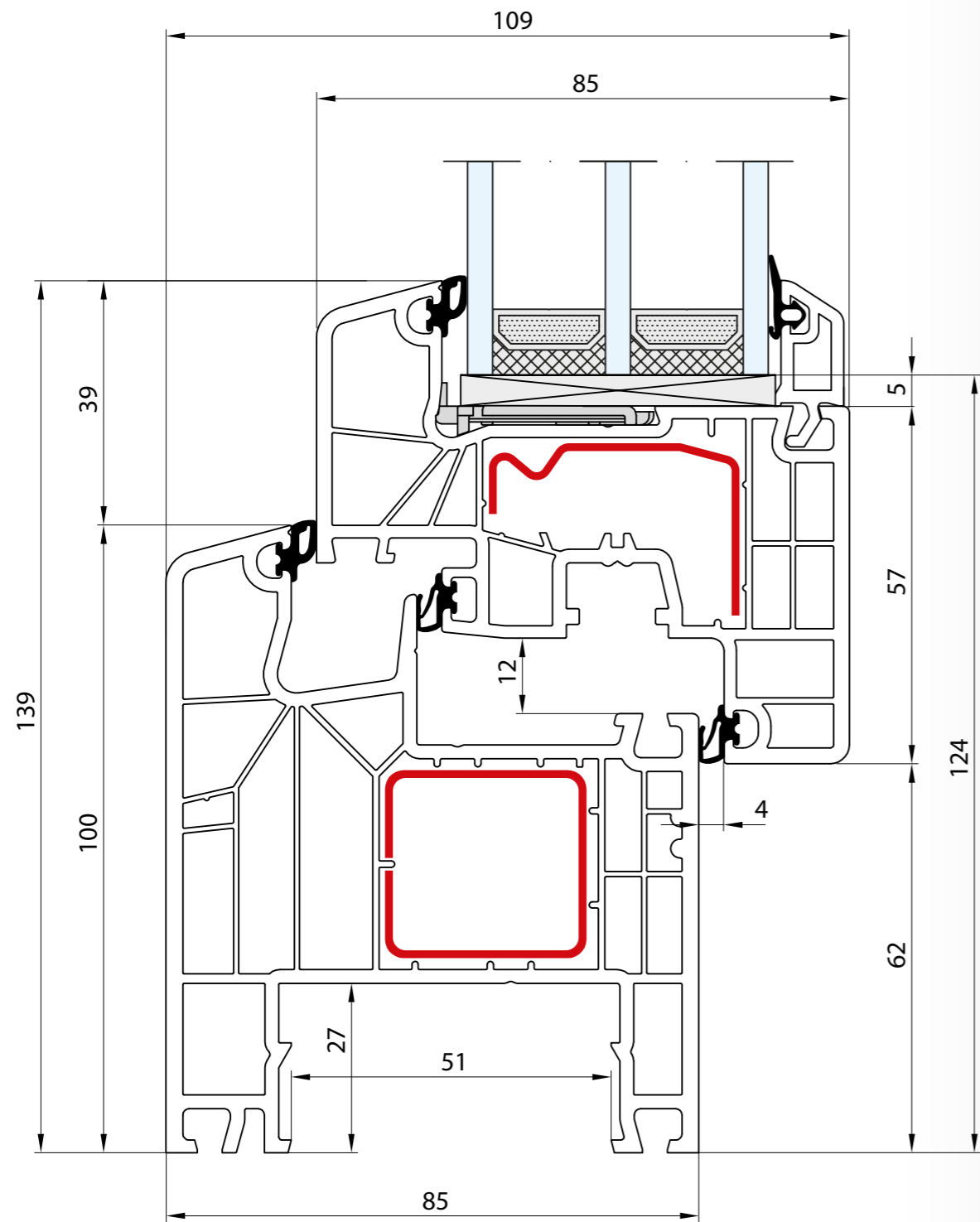

- Rama: 100 mm · Skrzydło: 77 mm
- Dormant: 100 mm · Vantail: 77 mm
- Frame: 100 mm · Sash: 77 mm
- Rahmen: 100 mm · Flügel: 77 mm
- Telaio: 100 mm · Anta: 77 mm

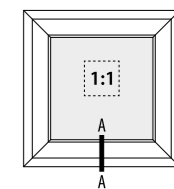
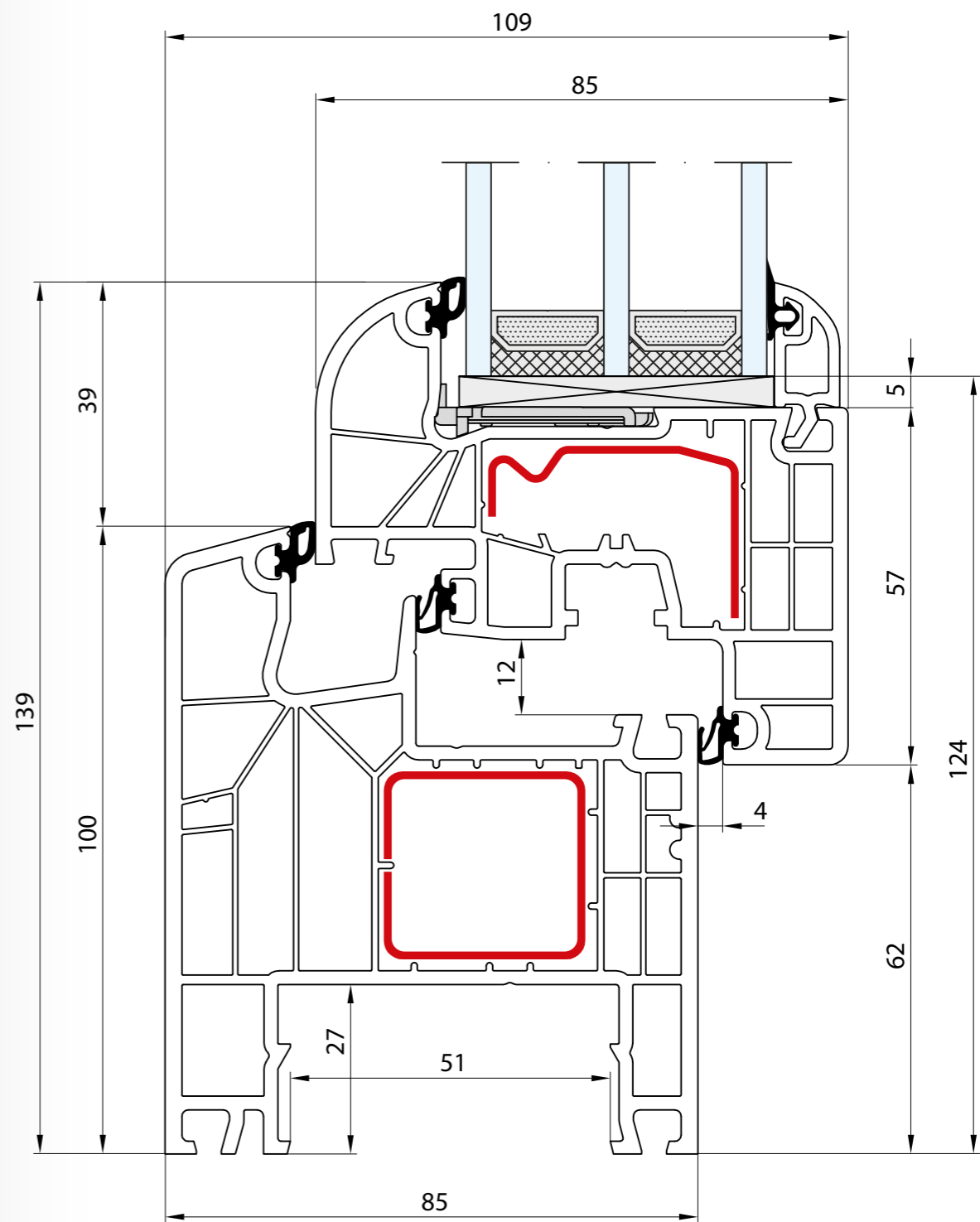

- Rama: 100 mm · Skrzydło: 77 mm
- Dormant: 100 mm · Vantail: 77 mm
- Frame: 100 mm · Sash: 77 mm
- Rahmen: 100 mm · Flügel: 77 mm
- Telaio: 100 mm · Anta: 77 mm

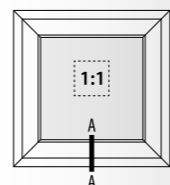
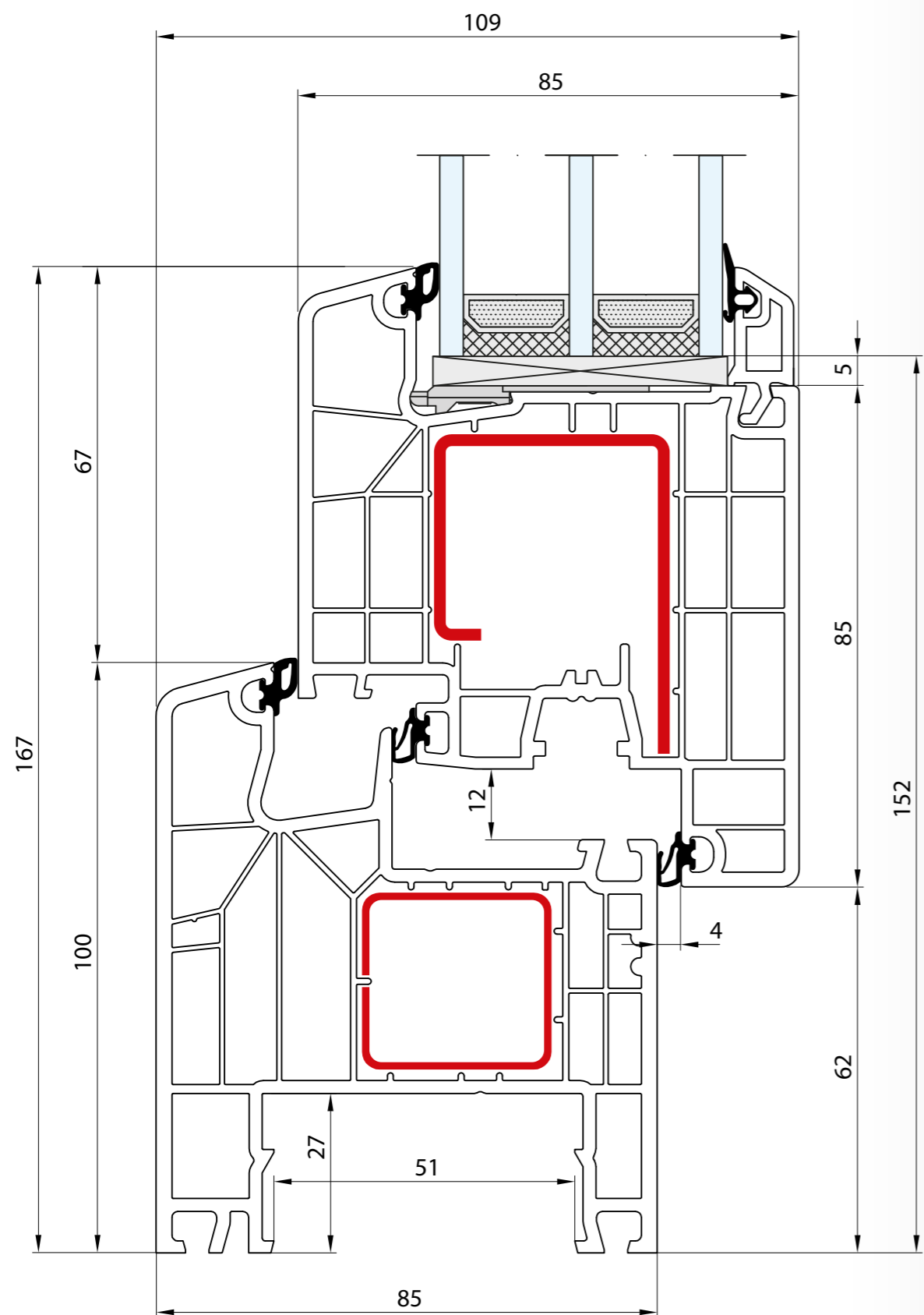

- Rama: 100 mm · Skrzydło: 105 mm
- Dormant: 100 mm · Vantail: 105 mm
- Frame: 100 mm · Sash: 105 mm
- Rahmen: 100 mm · Flügel: 105 mm
- Telaio: 100 mm · Anta: 105 mm

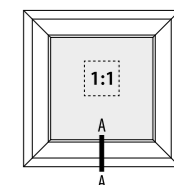
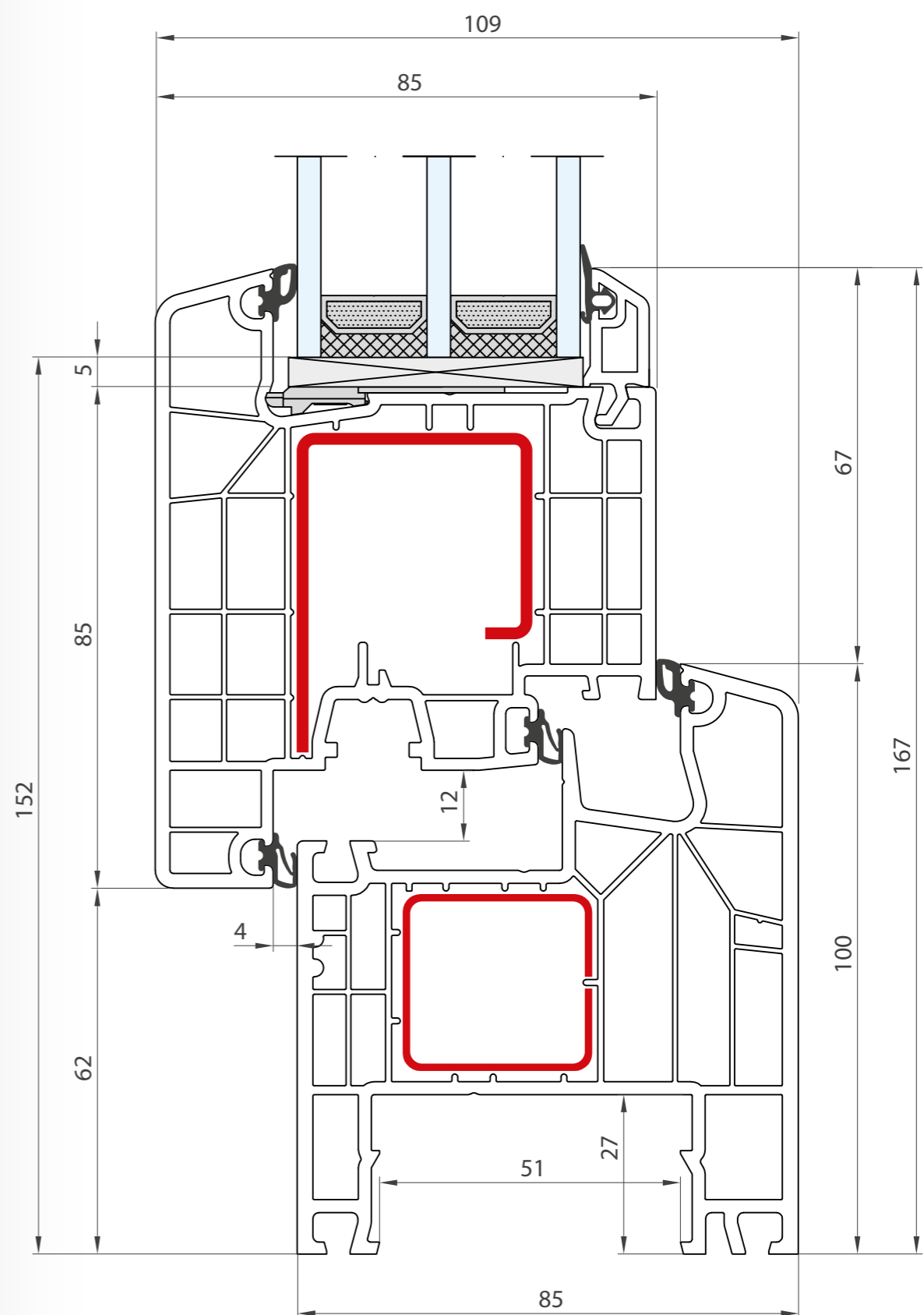

- Rama: 100 mm · Skrzydło: 105 mm
- Dormant: 100 mm · Vantail: 105 mm
- Frame: 100 mm · Sash: 105 mm
- Rahmen: 100 mm · Flügel: 105 mm
- Telaio: 100 mm · Anta: 105 mm

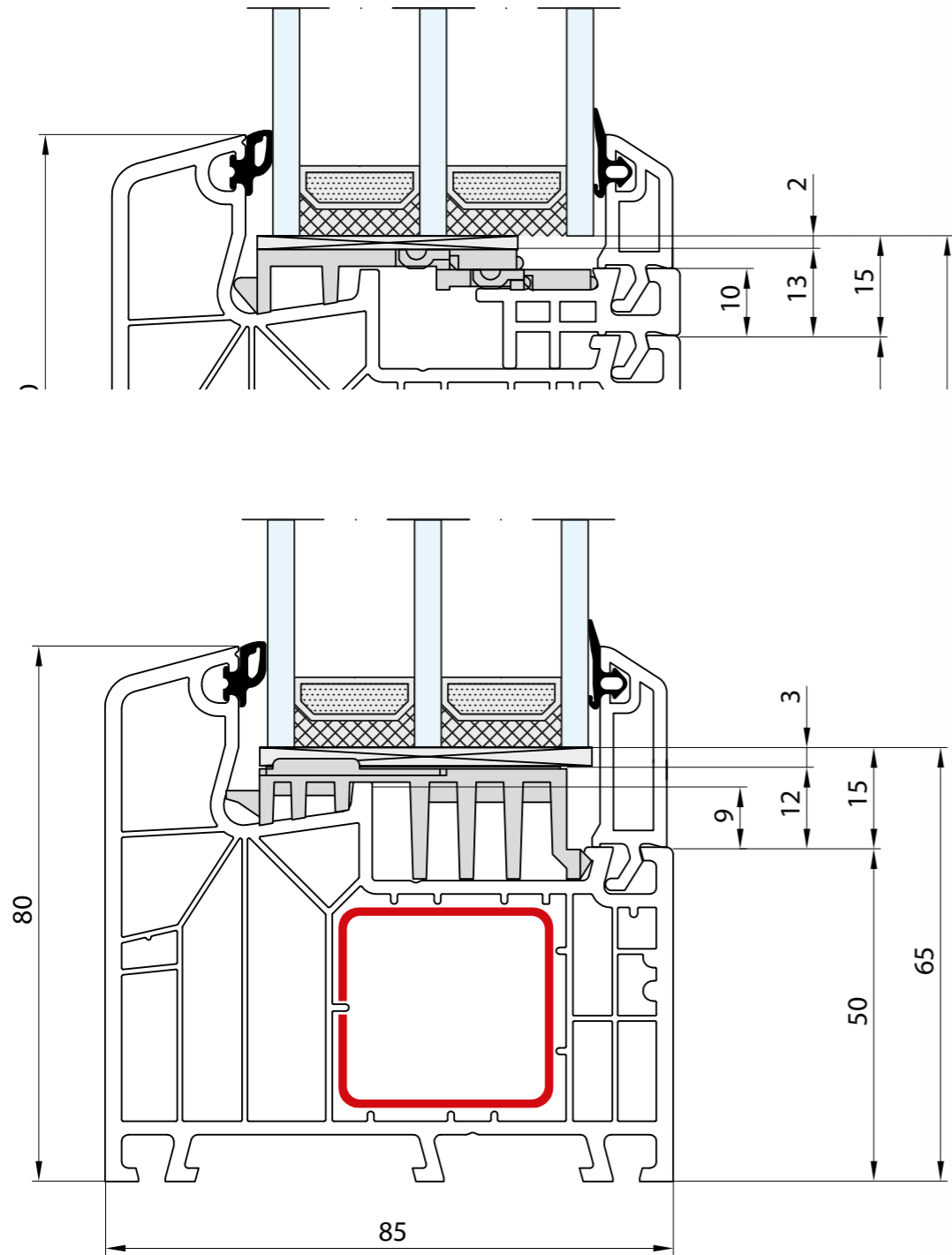

- Rama: 80 mm
- Dormant: 80 mm
- Frame: 80 mm
- Rahmen: 80 mm
- Telaio: 80 mm

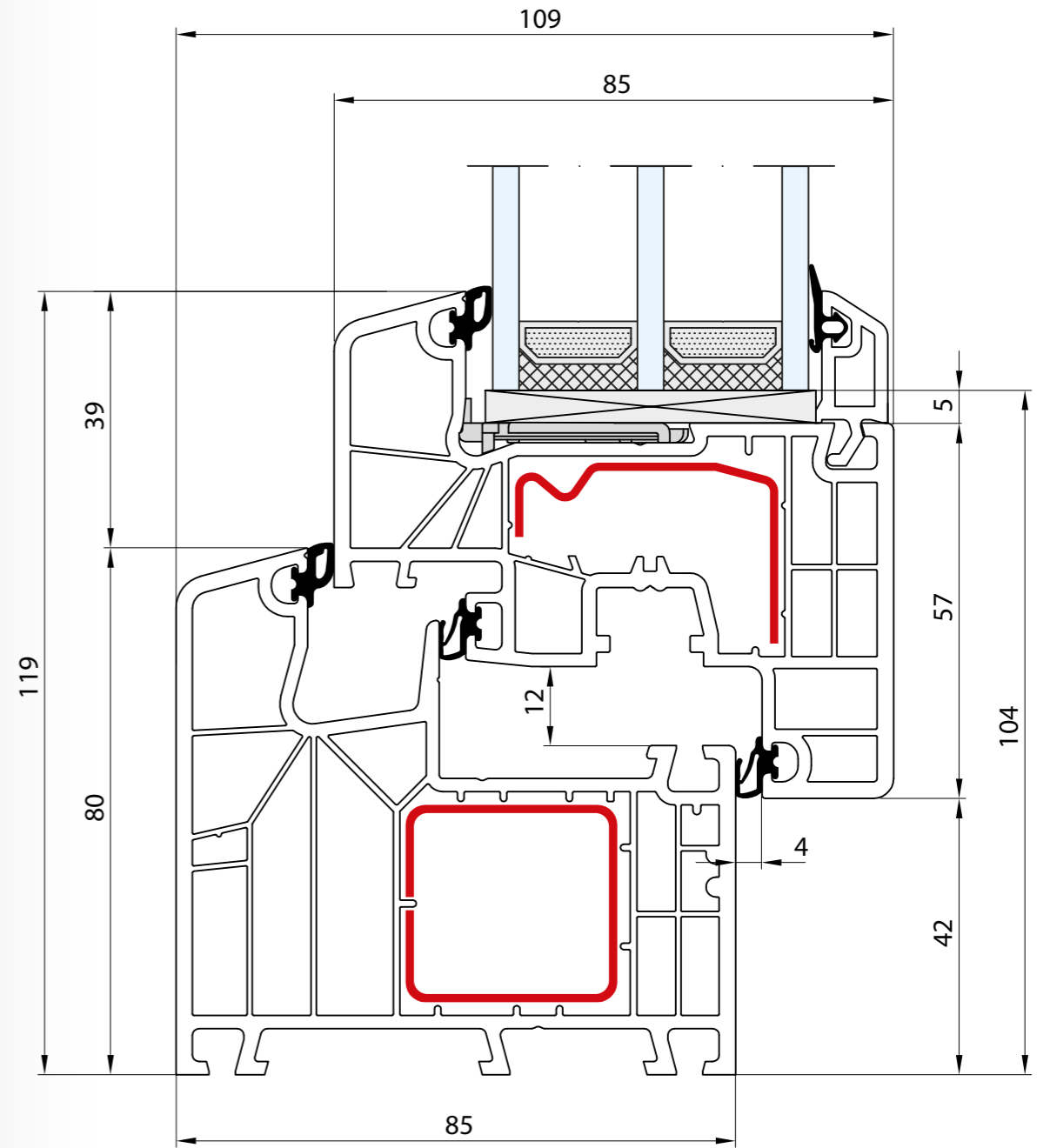
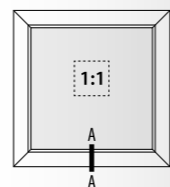

- Rama: 80 mm · Skrzydło: 77 mm
- Dormant: 80 mm · Vantail: 77 mm
- Frame: 80 mm · Sash: 77 mm
- Rahmen: 80 mm · Flügel: 77 mm
- Telaio: 80 mm · Anta: 77 mm

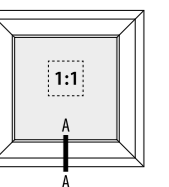

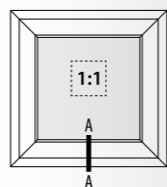
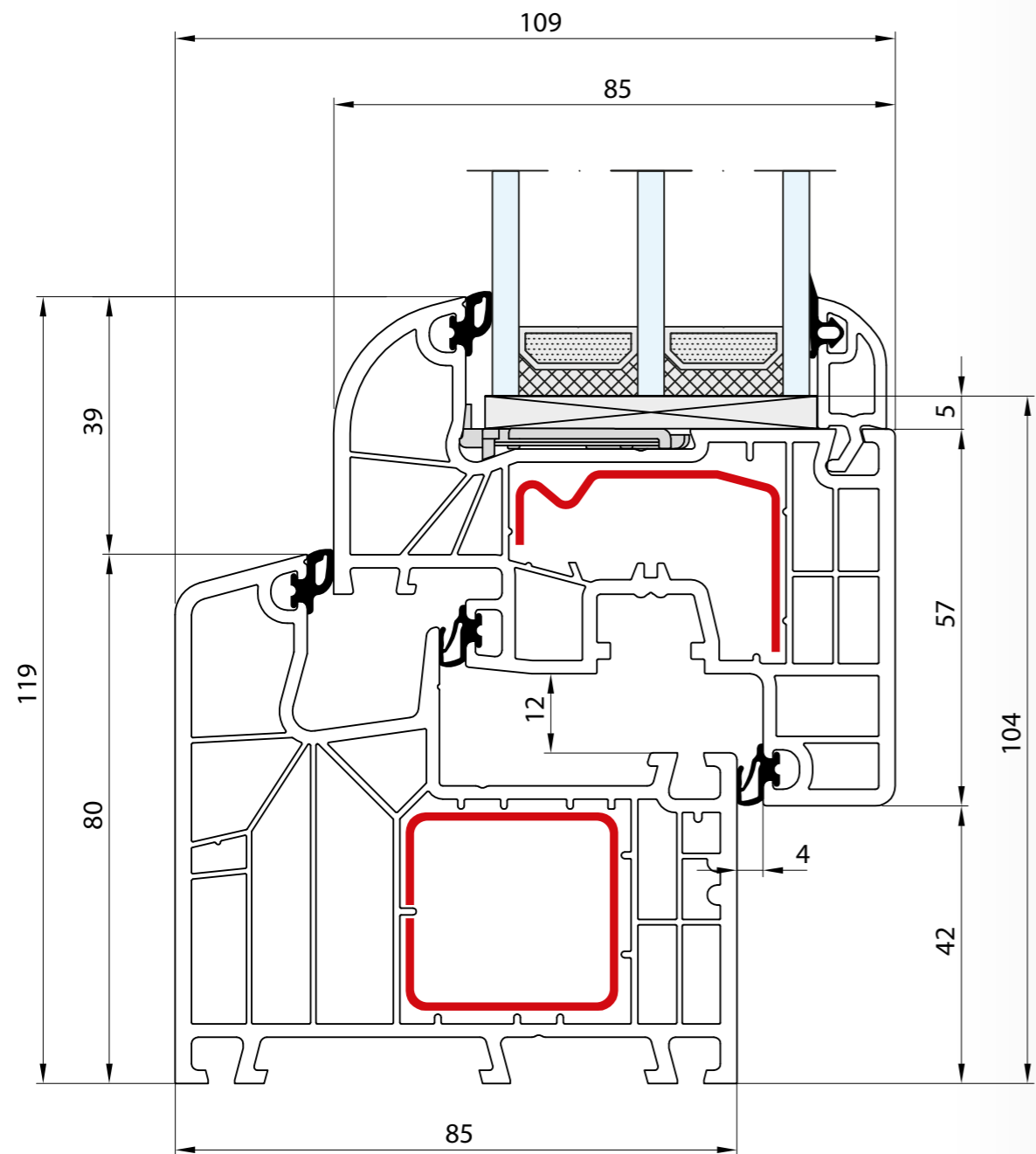

- Rama: 80 mm · Skrzydło: 77 mm
- Dormant: 80 mm · Vantail: 77 mm
- Frame: 80 mm · Sash: 77 mm
- Rahmen: 80 mm · Flügel: 77 mm
- Telaio: 80 mm · Anta: 77 mm

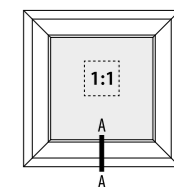
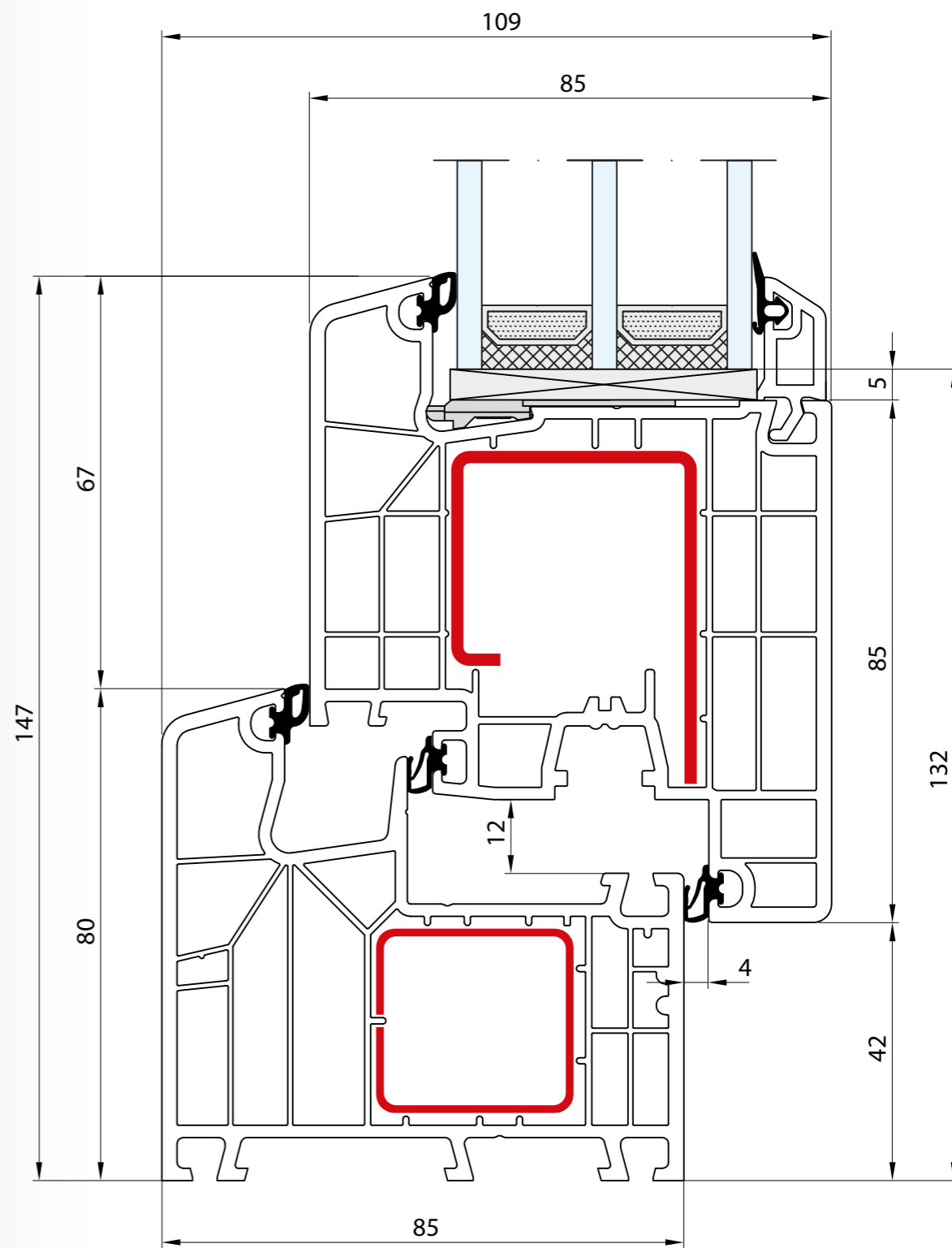

- Rama: 80 mm · Skrzydło: 105 mm
- Dormant: 80 mm · Vantail: 105 mm
- Frame: 80 mm · Sash: 105 mm
- Rahmen: 80 mm · Flügel: 105 mm
- Telaio: 80 mm · Anta: 105 mm

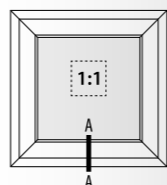
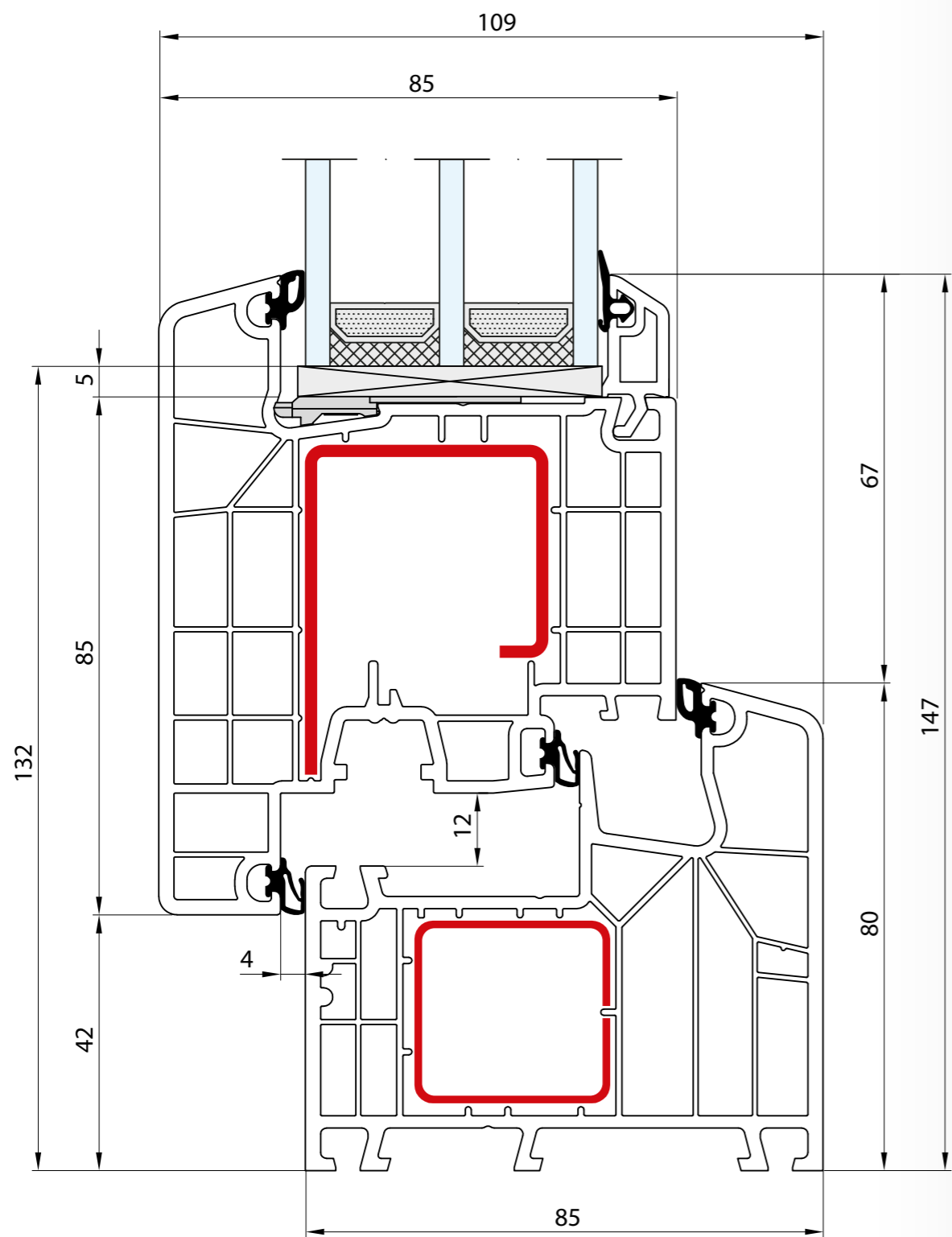

- Rama: 80 mm · Skrzydło: 105 mm
- Dormant: 80 mm · Vantail: 105 mm
- Frame: 80 mm · Sash: 105 mm
- Rahmen: 80 mm · Flügel: 105 mm
- Telaio: 80 mm · Anta: 105 mm

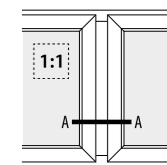
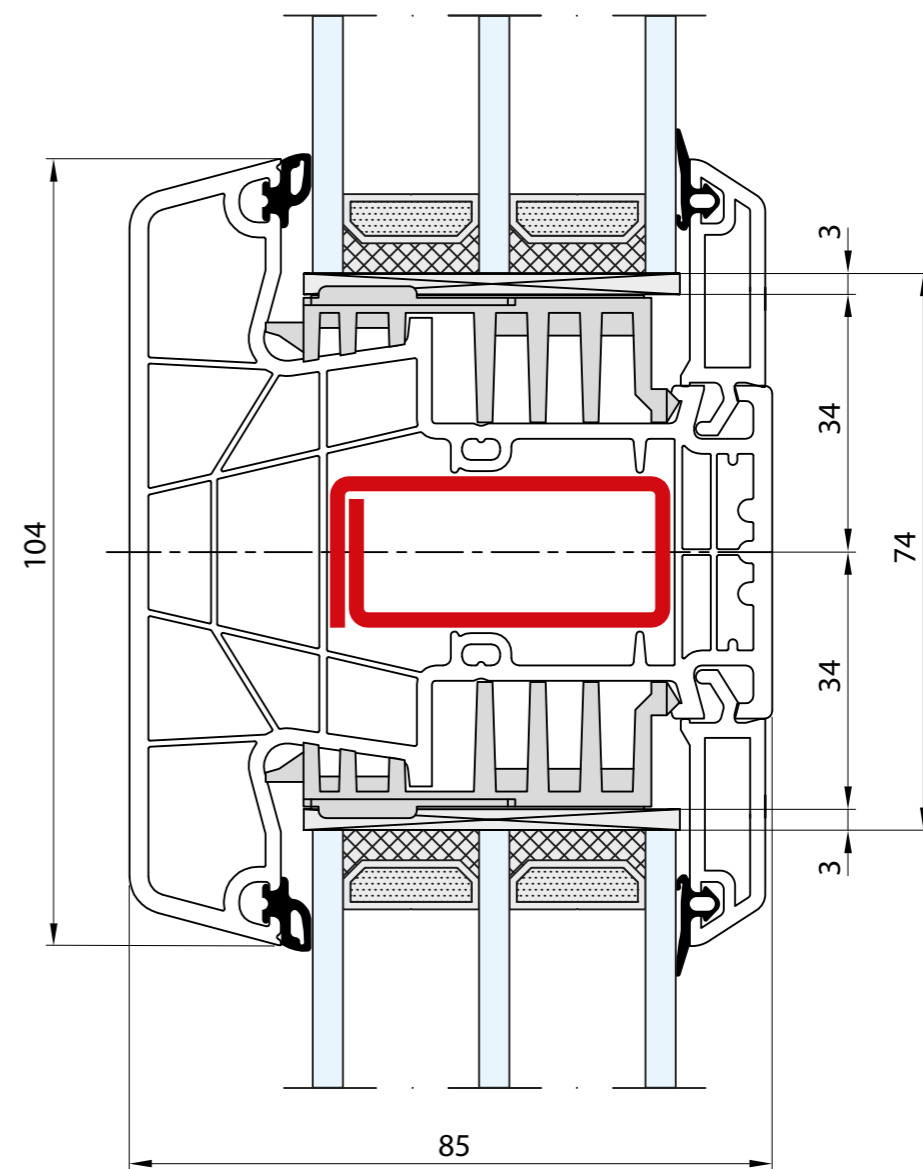

- Słupek stały: 104 mm
- Meneau fixe: 104 mm
- Fix post: 104 mm
- Festem Pfahl: 104 mm
- Montante fisso: 104 mm

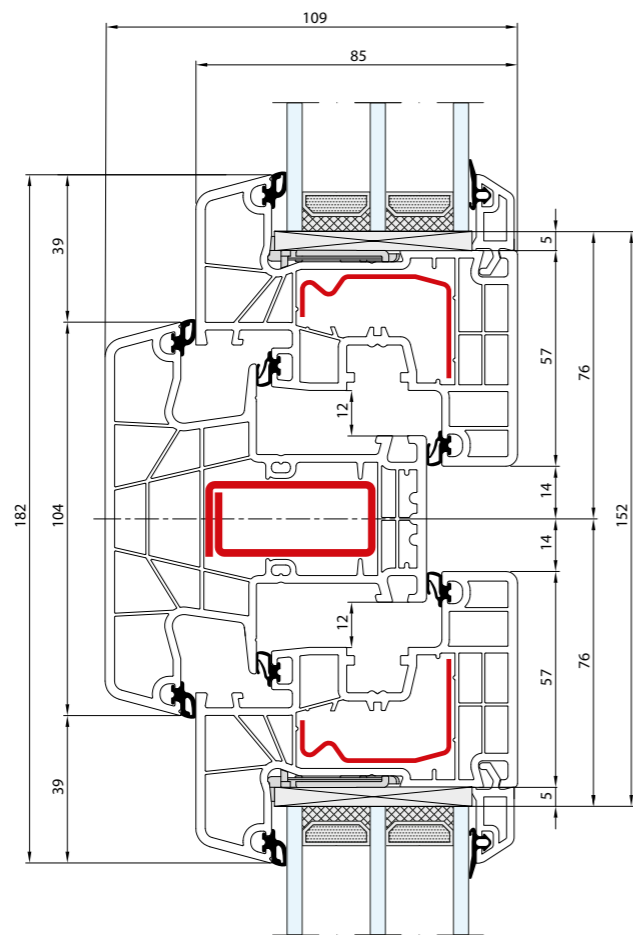

- Słupek stały: 104 mm · Skrzydło: 77 mm
- Meneau fixe: 104 mm · Vantail: 77 mm
- Fix post: 104 mm · Sash: 77 mm
- Festem Pfahl: 104 mm · Flügel: 77 mm
- Montante fisso: 104 mm · Anta: 77 mm

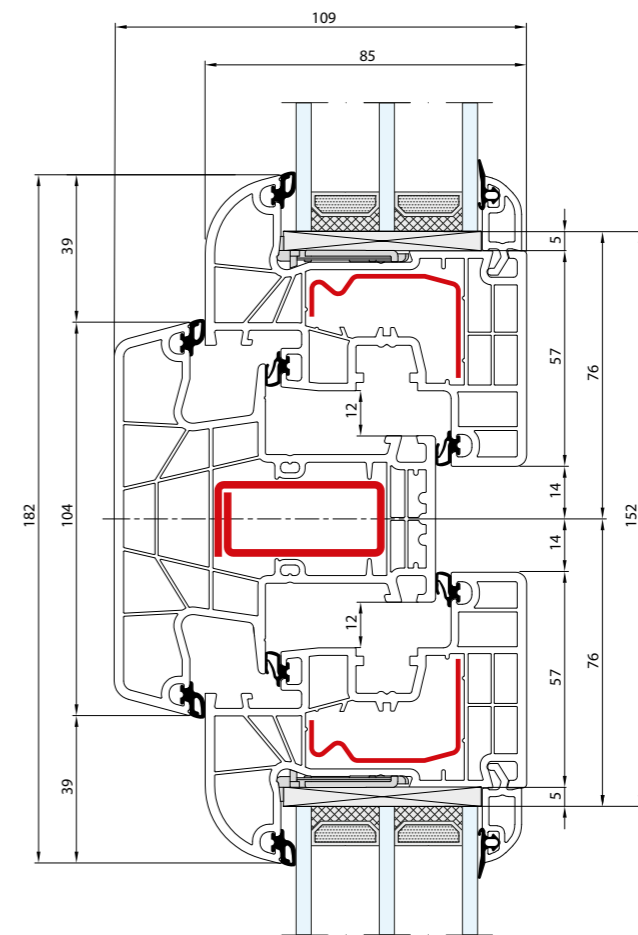
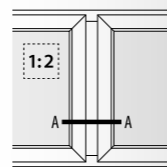

- Słupek stały: 104 mm · Skrzydło: 77 mm
- Meneau fixe: 104 mm · Vantail: 77 mm
- Fix post: 104 mm · Sash: 77 mm
- Festem Pfahl: 104 mm · Flügel: 77 mm
- Montante fisso: 104 mm · Anta: 77 mm

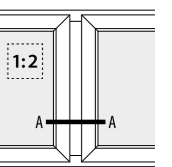

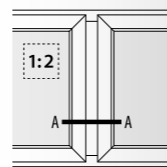
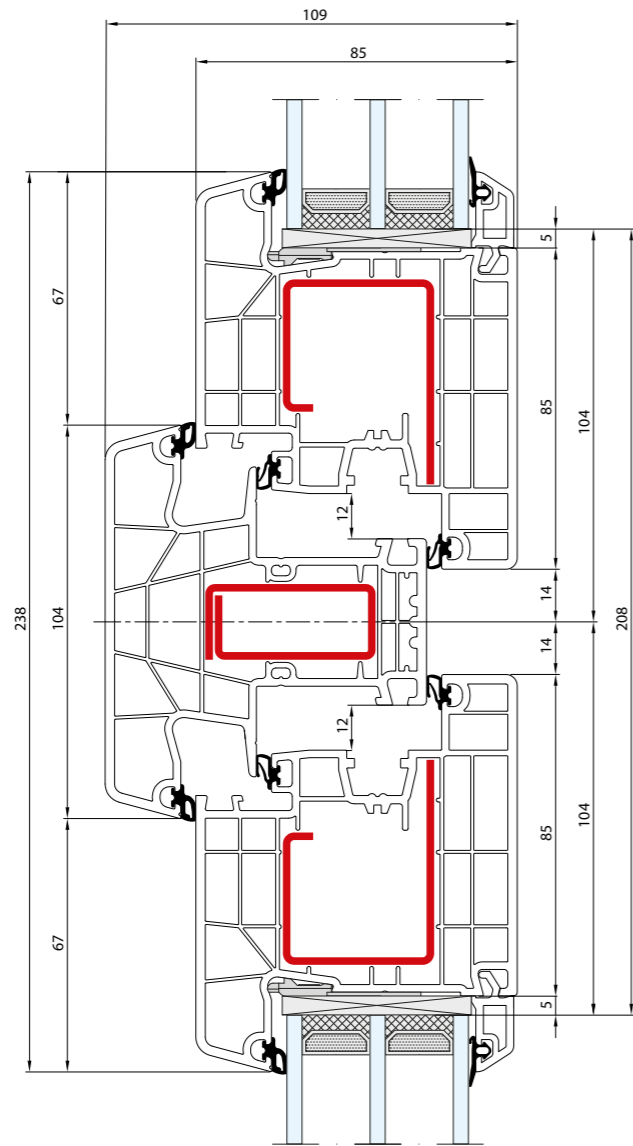

- Słupek stały: 104 mm · Skrzydło: 105 mm
- Meneau fixe: 104 mm · Vantail: 105 mm
- Fix post: 104 mm · Sash: 105 mm
- Festem Pfahl: 104 mm · Flügel: 105 mm
- Montante fisso: 104 mm · Anta: 105 mm

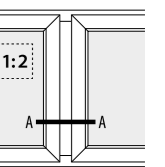
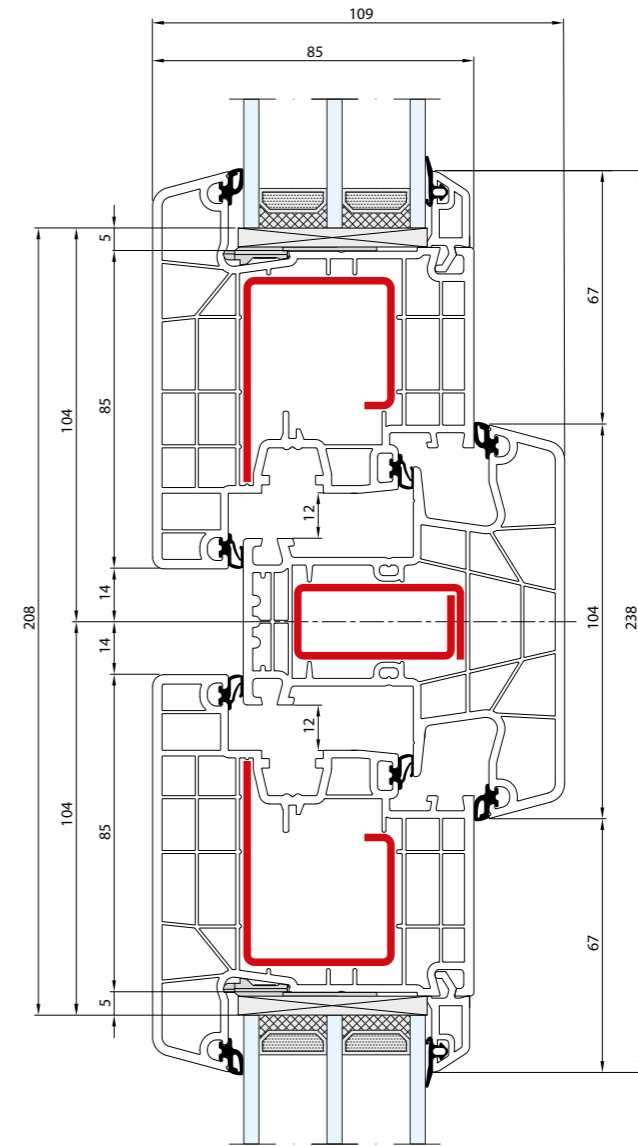

- Słupek stały: 104 mm · Skrzydło: 105 mm
- Meneau fixe: 104 mm · Vantail: 105 mm
- Fix post: 104 mm · Sash: 105 mm
- Festem Pfahl: 104 mm · Flügel: 105 mm
- Montante fisso: 104 mm · Anta: 105 mm

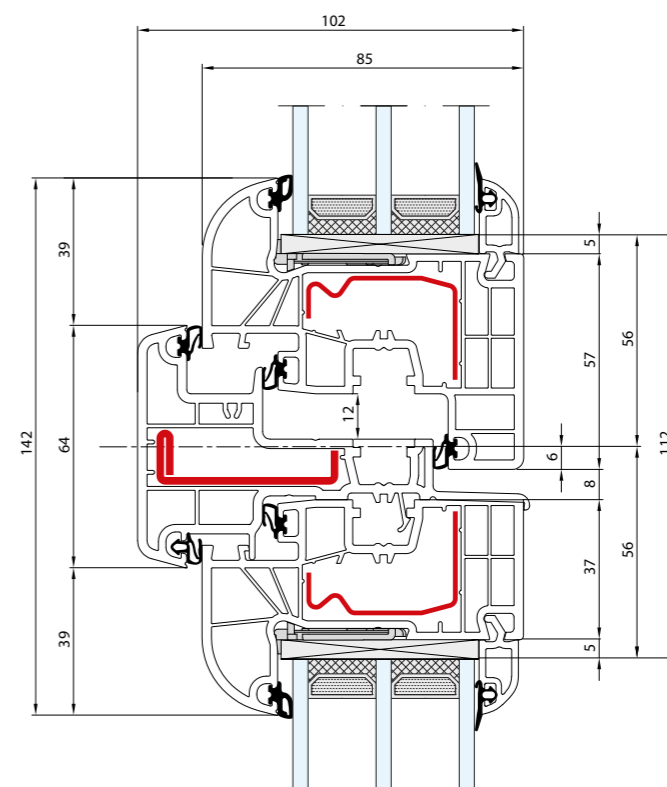
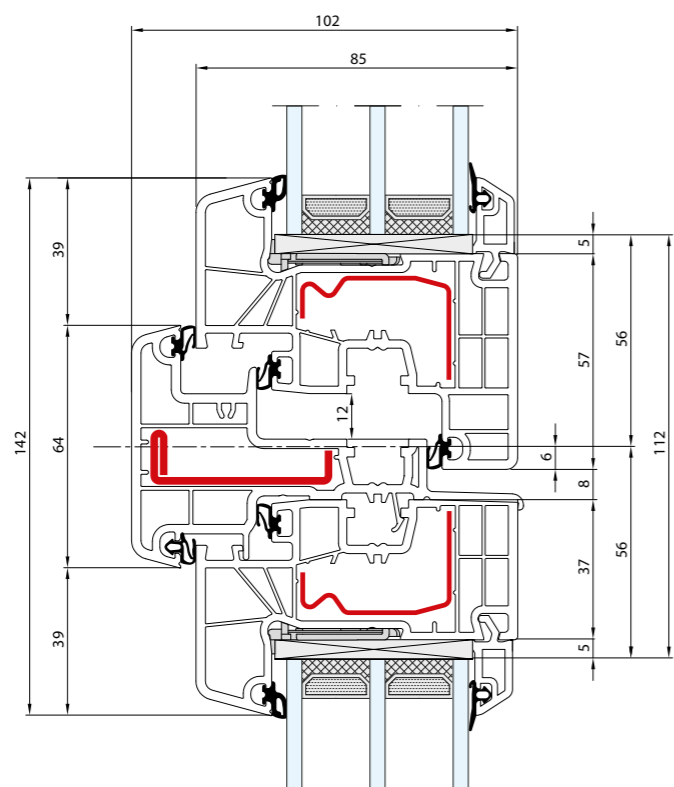

- Słupek ruchomy: 64 mm · Skrzydło: 77 mm / 57 mm
- Meneau mobile: 64 mm · Vantail: 77 mm / 57 mm
- Movable post: 64 mm · Sash: 77 mm / 57 mm
- Stulp: 64 mm · Flügel: 77 mm / 57 mm
- Montante mobile: 64 mm · Anta: 77 mm / 57 mm

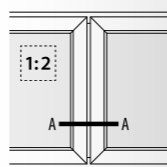

- Słupek ruchomy: 64 mm · Skrzydło: 77 mm / 57 mm
- Meneau mobile: 64 mm · Vantail: 77 mm / 57 mm
- Movable post: 64 mm · Sash: 77 mm / 57 mm
- Stulp: 64 mm · Flügel: 77 mm / 57 mm
- Montante mobile: 64 mm · Anta: 77 mm / 57 mm

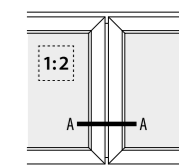

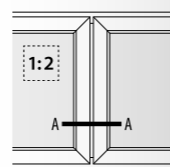
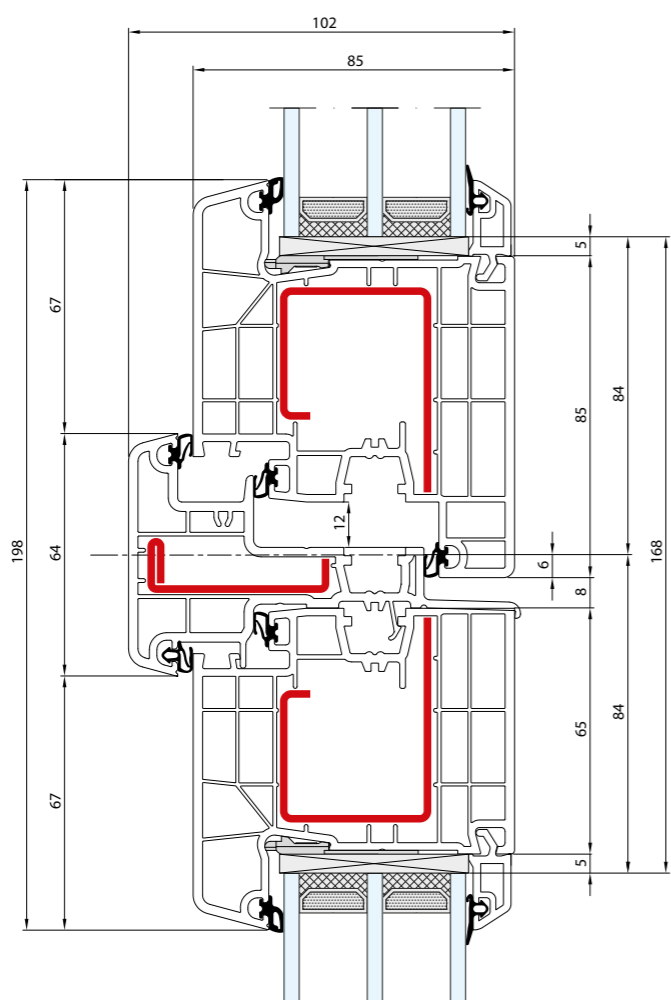

- Słupek ruchomy: 64 mm · Skrzydło: 105 mm / 85 mm
- Meneau mobile: 64 mm · Vantail: 105 mm / 85 mm
- Movable post: 64 mm · Sash: 105 mm / 85 mm
- Stulp: 64 mm · Flügel: 105 mm / 85 mm
- Montante mobile: 64 mm · Anta: 105 mm / 85 mm

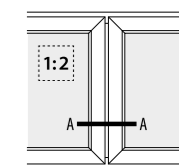
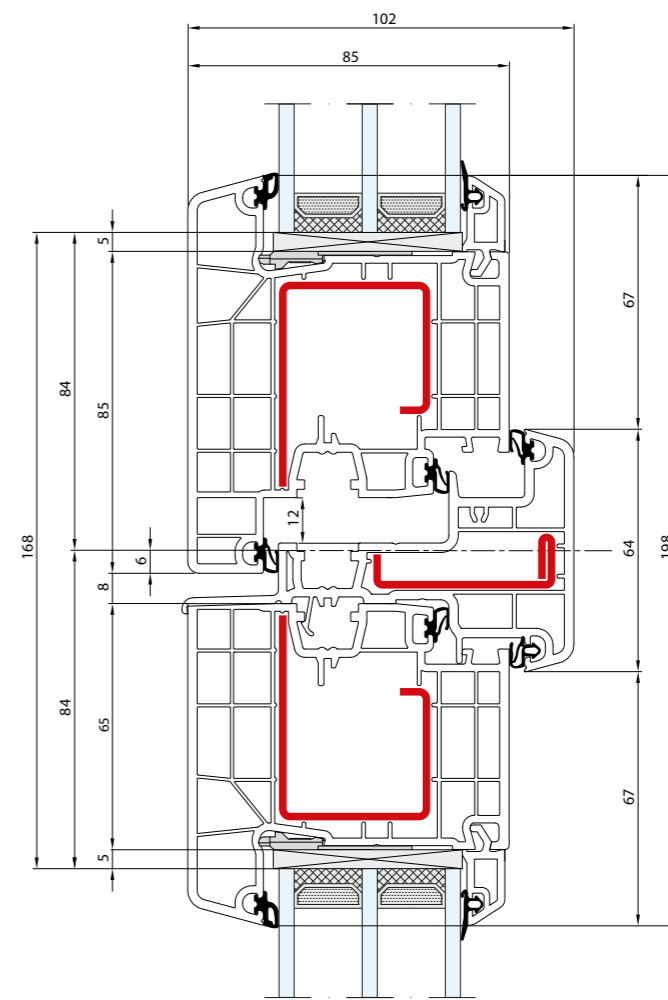

- Słupek ruchomy: 64 mm · Skrzydło: 105 mm / 85 mm
- Meneau mobile: 64 mm · Vantail: 105 mm / 85 mm
- Movable post: 64 mm · Sash: 105 mm / 85 mm
- Stulp: 64 mm · Flügel: 105 mm / 85 mm
- Montante mobile: 64 mm · Anta: 105 mm / 85 mm

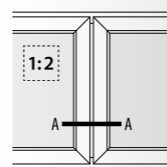
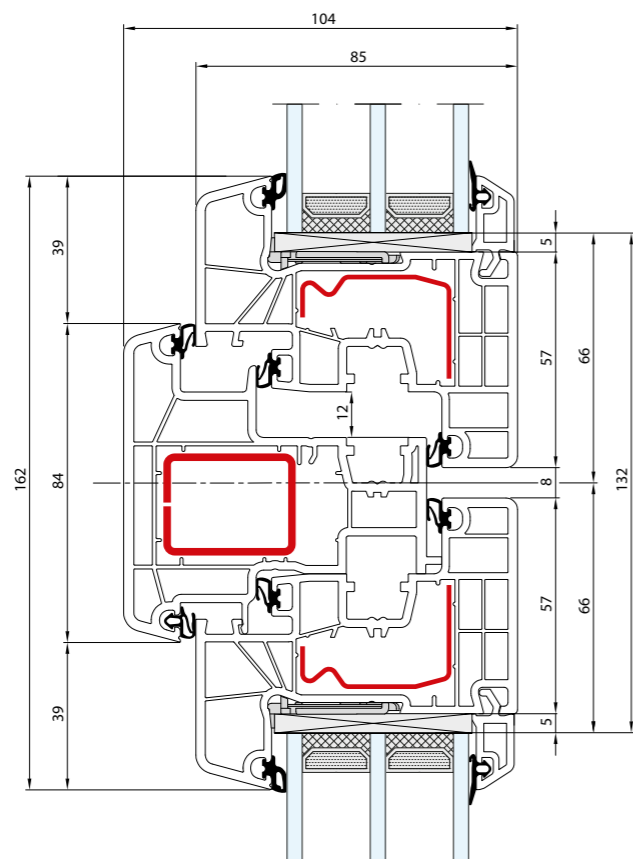

- Słupek ruchomy: 84 mm · Skrzydło: 77 mm
- Meneau mobile: 84 mm · Vantail: 77 mm
- Movable post: 84 mm · Sash: 77 mm
- Stulp: 84 mm · Flügel: 77 mm
- Montante mobile: 84 mm · Anta: 77 mm

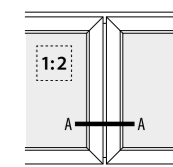
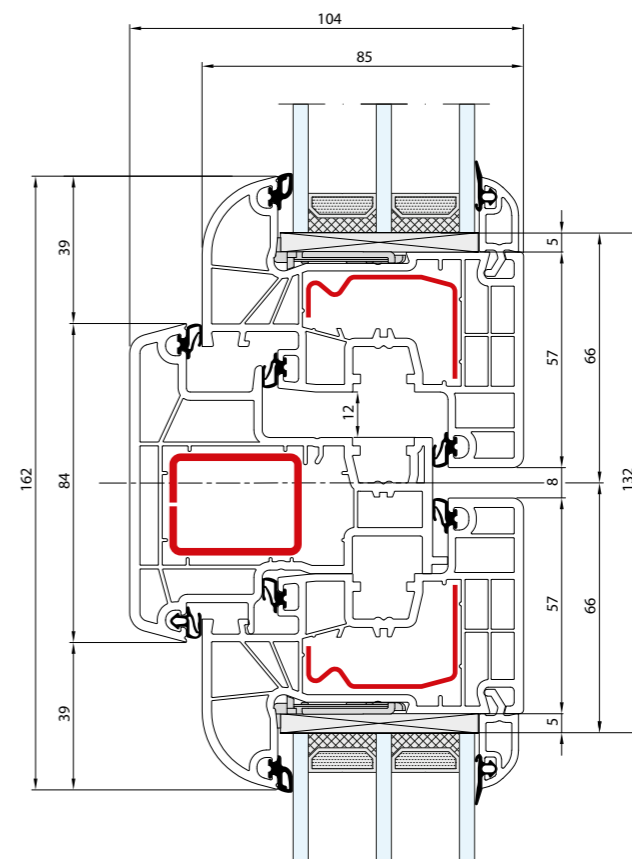

- Słupek ruchomy: 84 mm · Skrzydło: 77 mm
- Meneau mobile: 84 mm · Vantail: 77 mm
- Movable post: 84 mm · Sash: 77 mm
- Stulp: 84 mm · Flügel: 77 mm
- Montante mobile: 84 mm · Anta: 77 mm

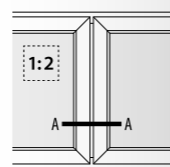
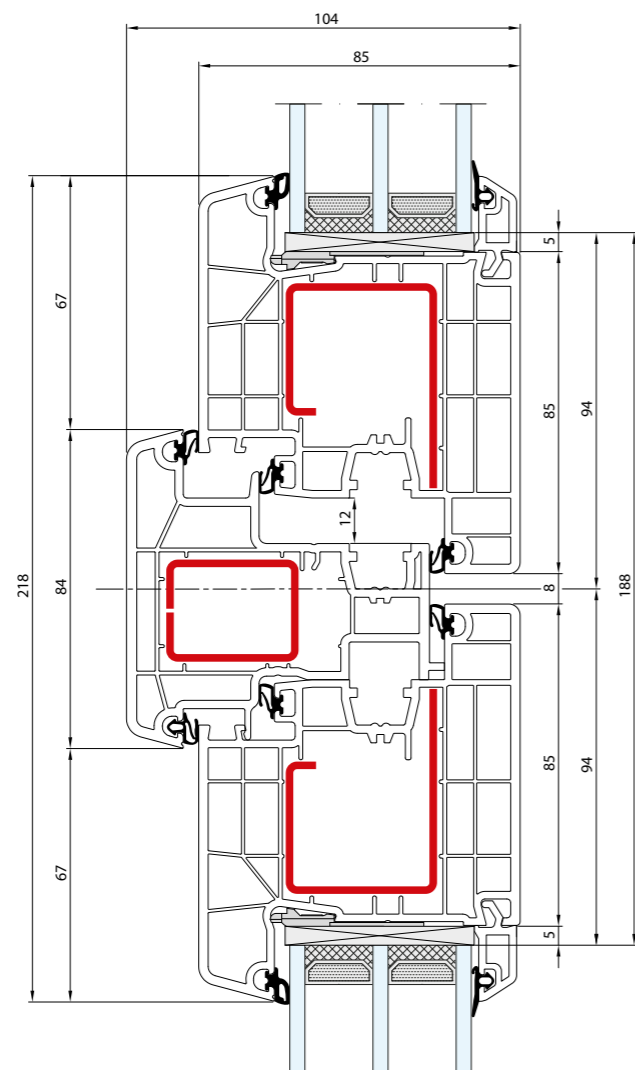

- Słupek ruchomy: 84 mm · Skrzydło: 105 mm
- Meneau mobile: 84 mm · Vantail: 105 mm
- Movable post: 84 mm · Sash: 105 mm
- Stulp: 84 mm · Flügel: 105 mm
- Montante mobile: 84 mm · Anta: 105 mm

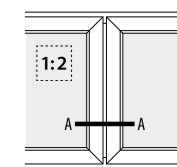
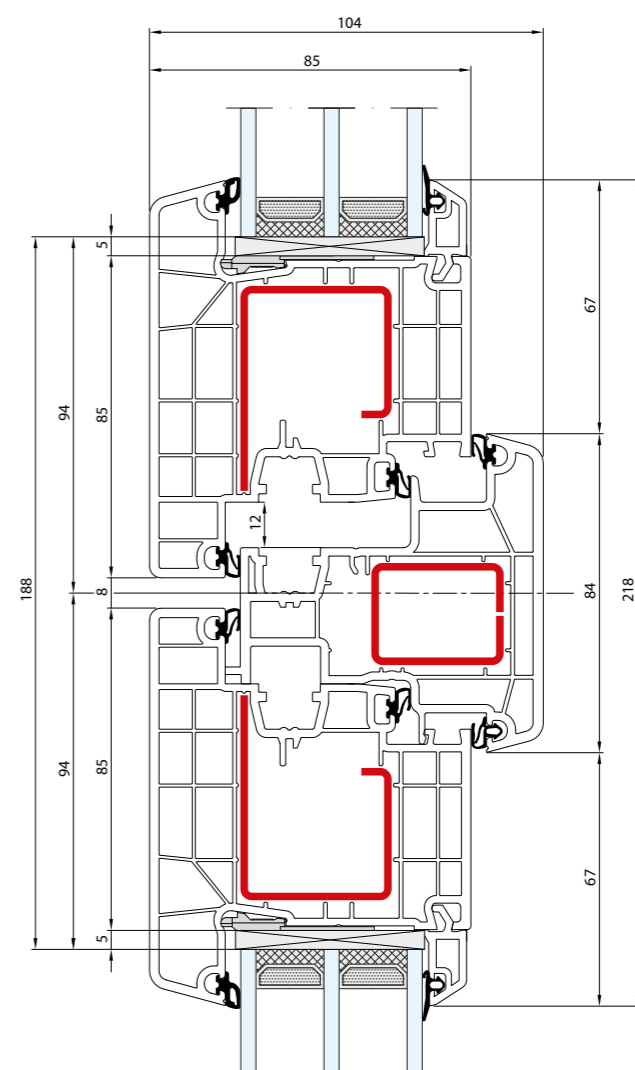

- Słupek ruchomy: 84 mm · Skrzydło: 105 mm
- Meneau mobile: 84 mm · Vantail: 105 mm
- Movable post: 84 mm · Sash: 105 mm
- Stulp: 84 mm · Flügel: 105 mm
- Montante mobile: 84 mm · Anta: 105 mm

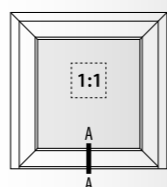
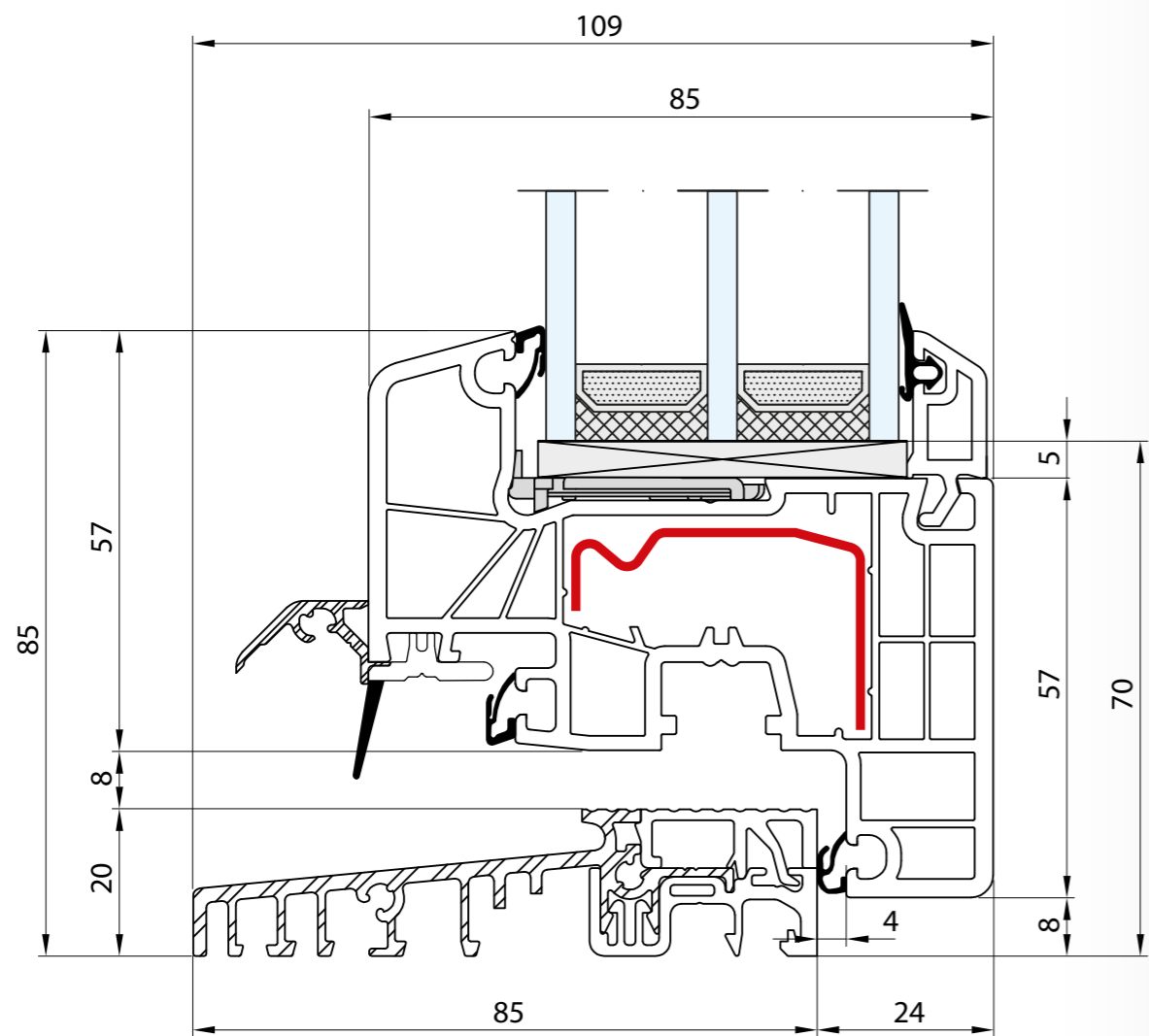

- Próg: 20 mm · Skrzydło: 77 mm
- Seuil: 20 mm · Vantail: 77 mm
- Threshold: 20 mm · Sash: 77 mm
- Schwelle: 20 mm · Flügel: 77 mm
- Soglia: 20 mm · Anta: 77 mm

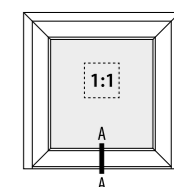
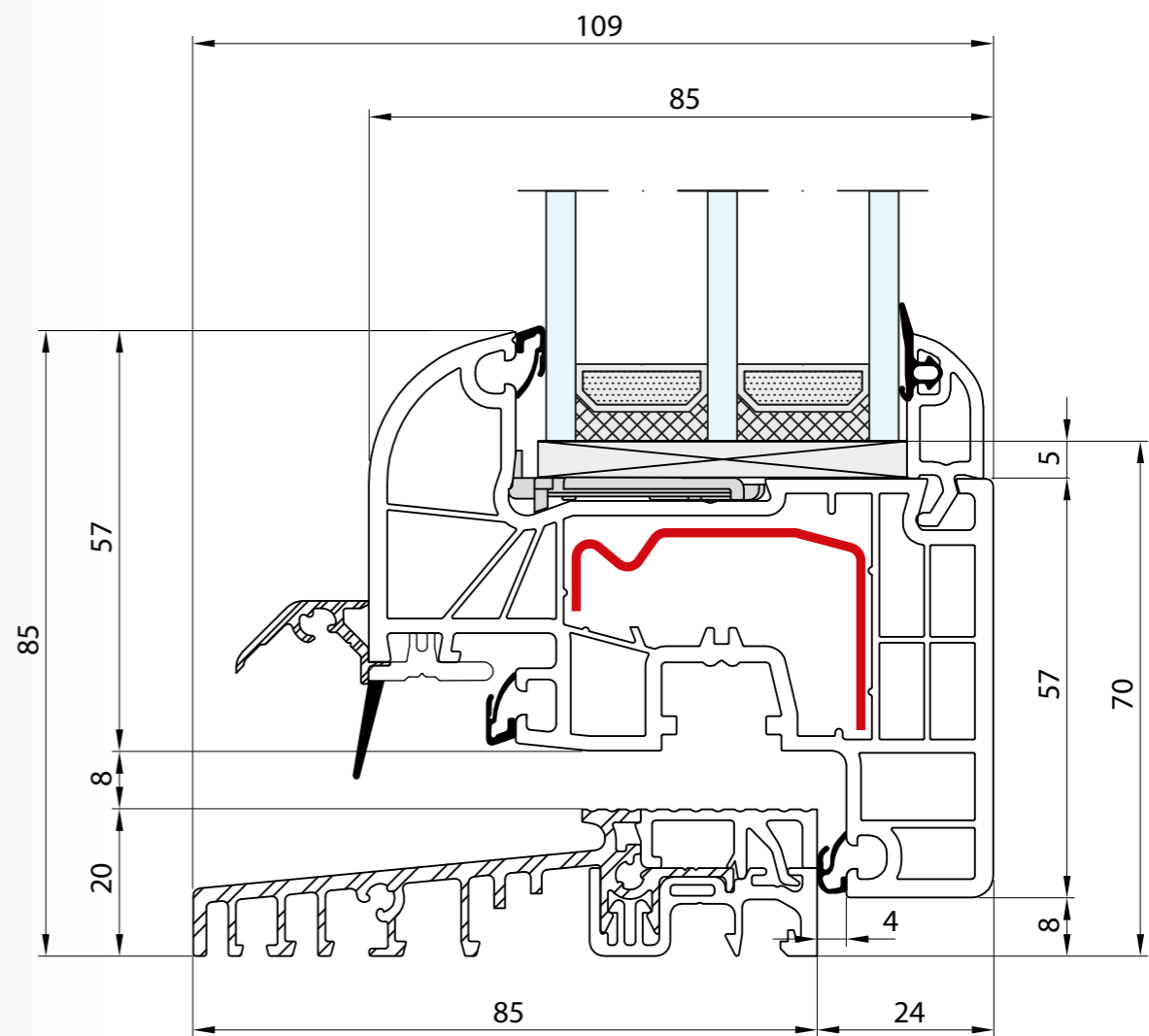

- Próg: 20 mm · Skrzydło: 77 mm
- Seuil: 20 mm · Vantail: 77 mm
- Threshold: 20 mm · Sash: 77 mm
- Schwelle: 20 mm · Flügel: 77 mm
- Soglia: 20 mm · Anta: 77 mm

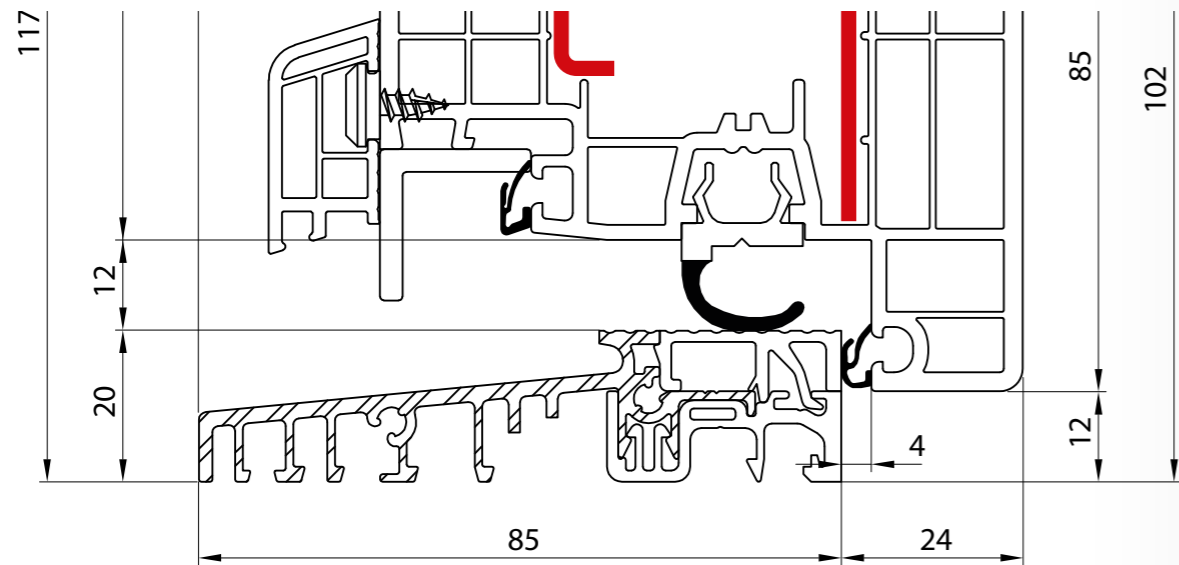
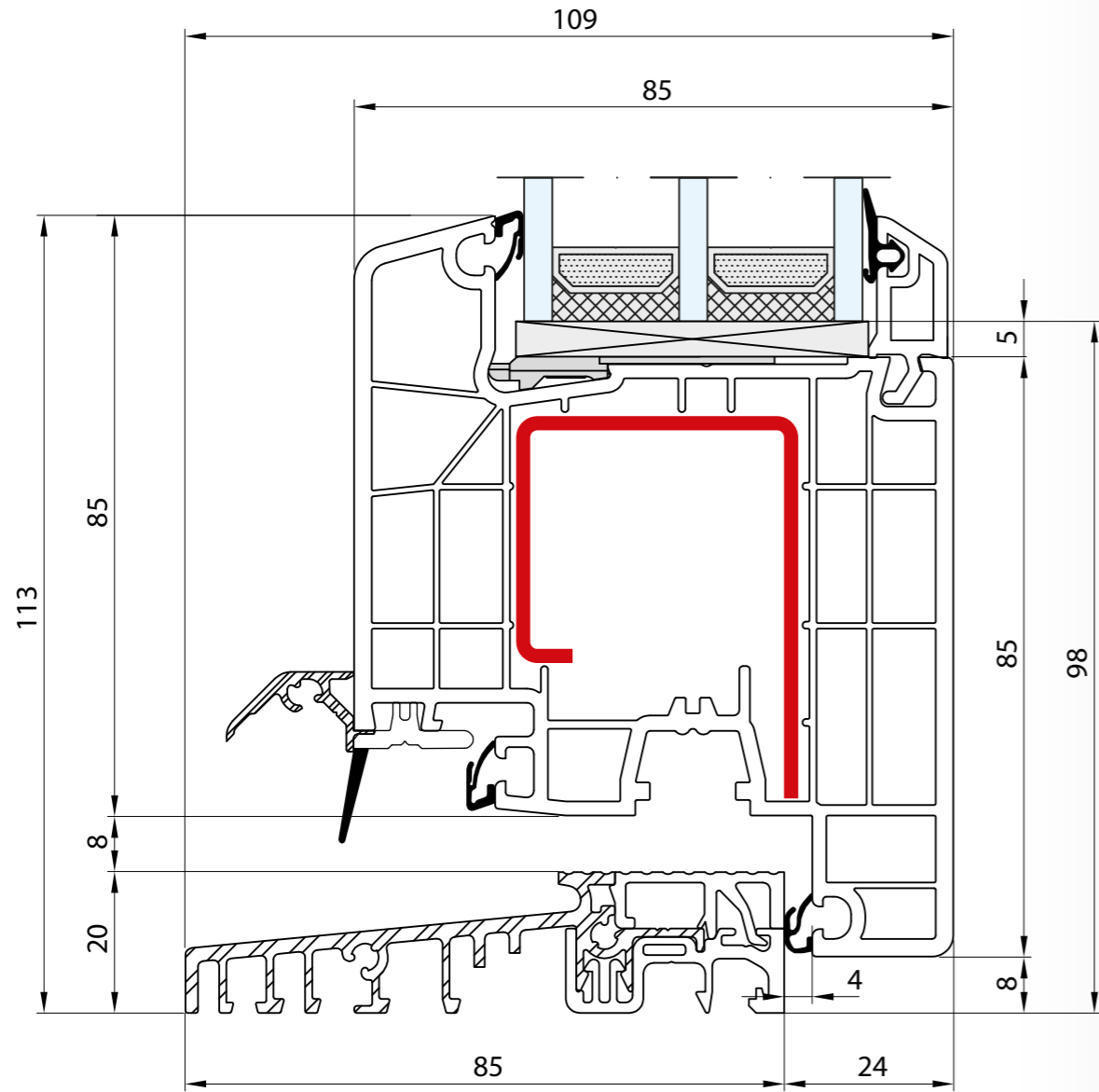

- Próg: 20 mm · Skrzydło: 105 mm
- Seuil: 20 mm · Vantail: 105 mm
- Threshold: 20 mm · Sash: 105 mm
- Schwelle: 20 mm · Flügel: 105 mm
- Soglia: 20 mm · Anta: 105 mm

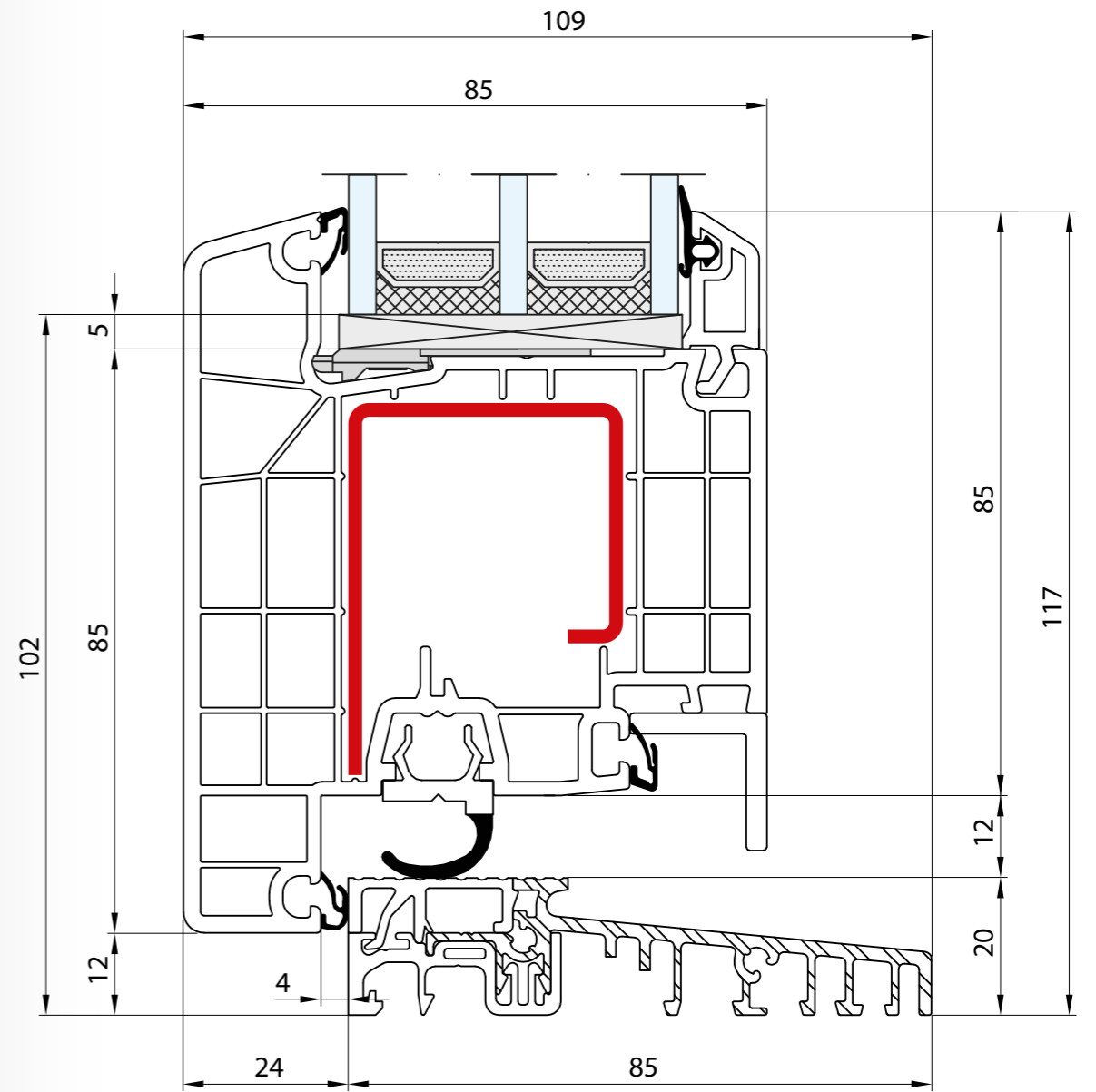
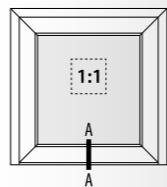

- Próg: 20 mm · Skrzydło: 105 mm
- Seuil: 20 mm · Vantail: 105 mm
- Threshold: 20 mm · Sash: 105 mm
- Schwelle: 20 mm · Flügel: 105 mm
- Soglia: 20 mm · Anta: 105 mm

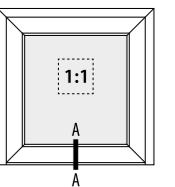

ENERGETO 8000

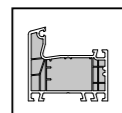

6



3

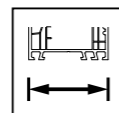

85

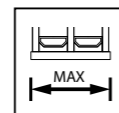

52

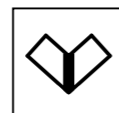

V-PERFECT
TECHNOLOGY



ALU



IDEAL 4000

IDEAL 4000 NEW

IDEAL 5000

IDEAL 7000 NEW

IDEAL 8000

ENERGETO 8000

IDEAL 4000

IDEAL 4000 NEW

IDEAL 5000

IDEAL 7000 NEW

IDEAL 8000

ENERGETO 8000

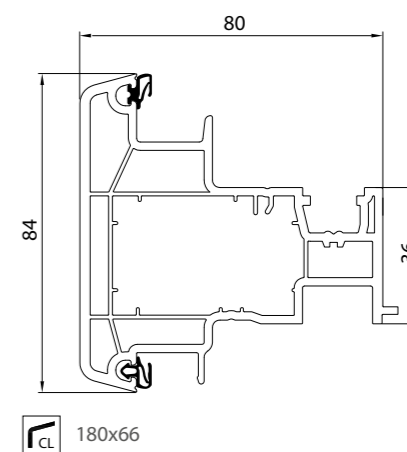
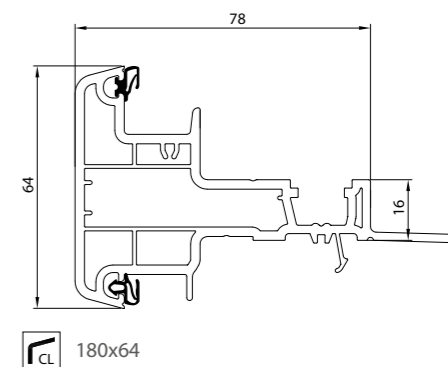
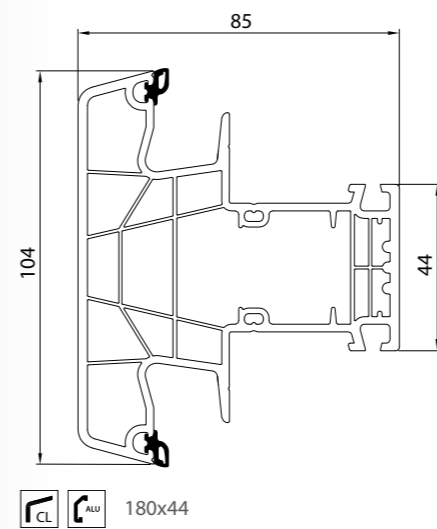
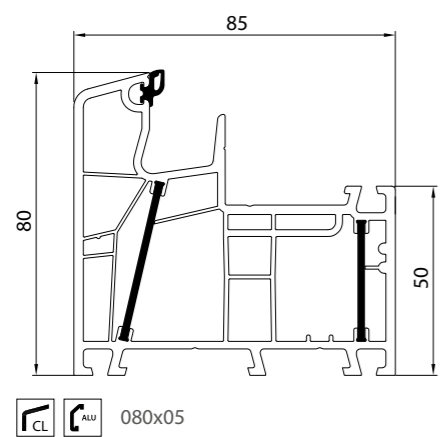
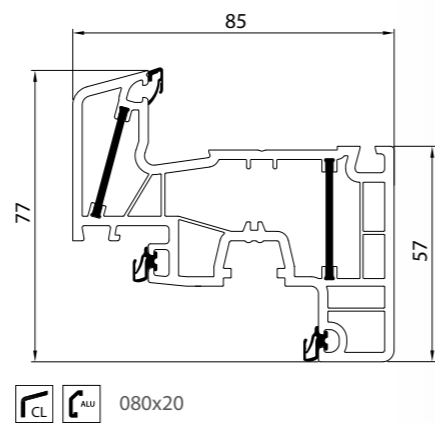
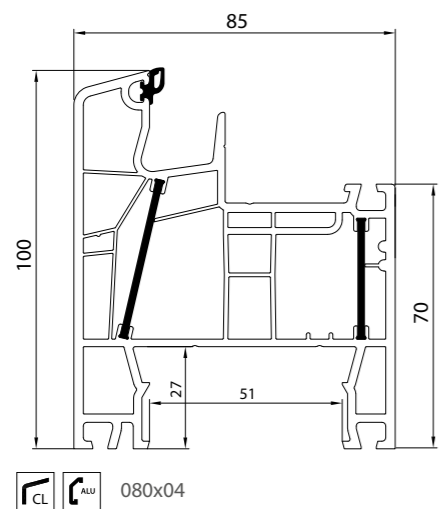

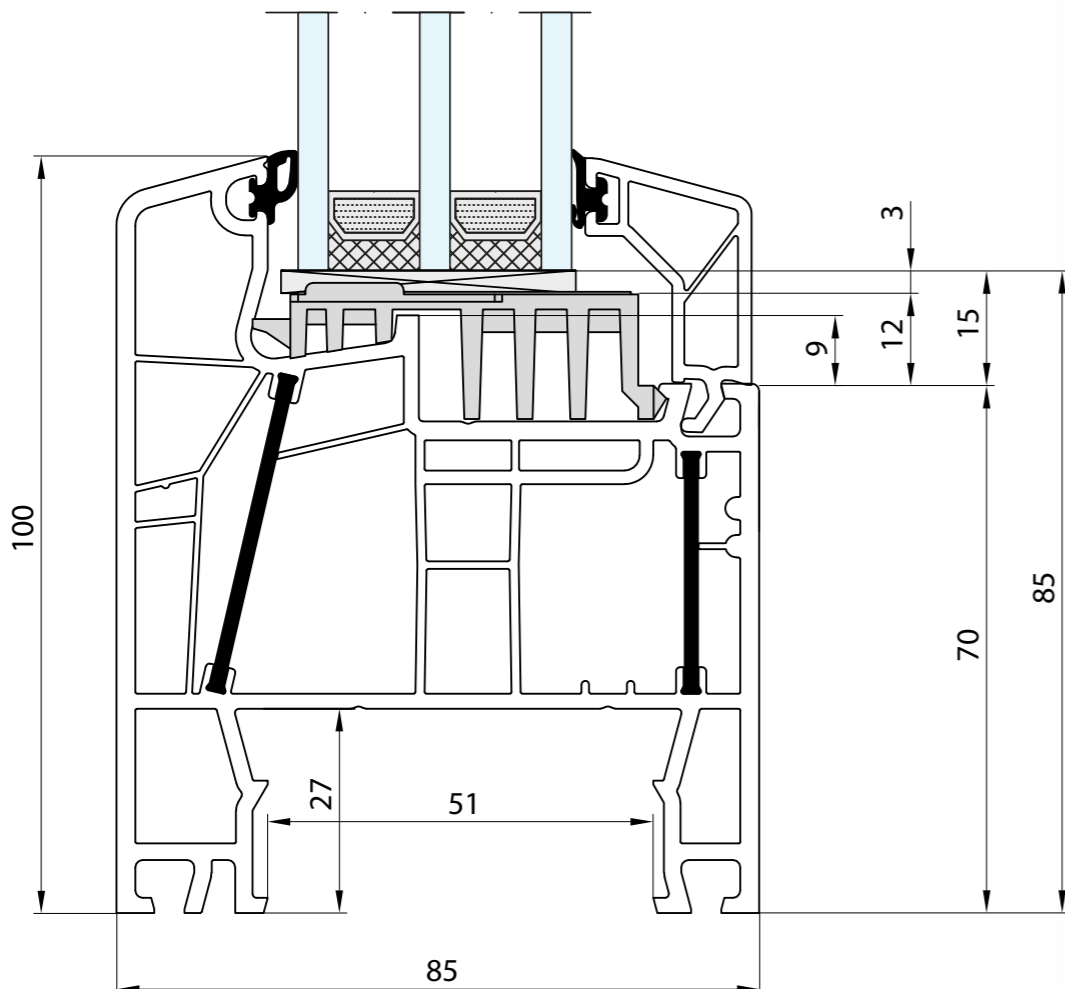
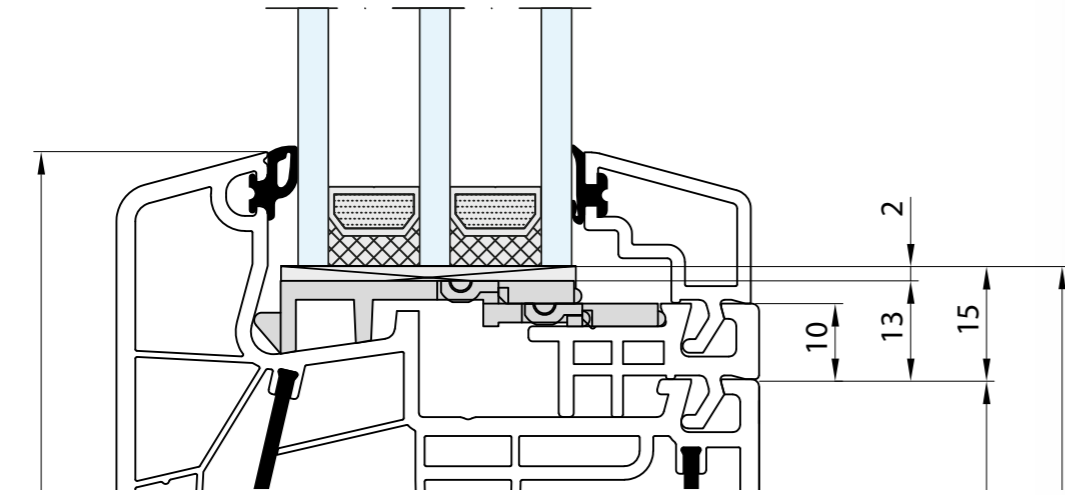

- Rama: 100 mm
- Dormant: 100 mm
- Frame: 100 mm
- Rahmen: 100 mm
- Telaio: 100 mm

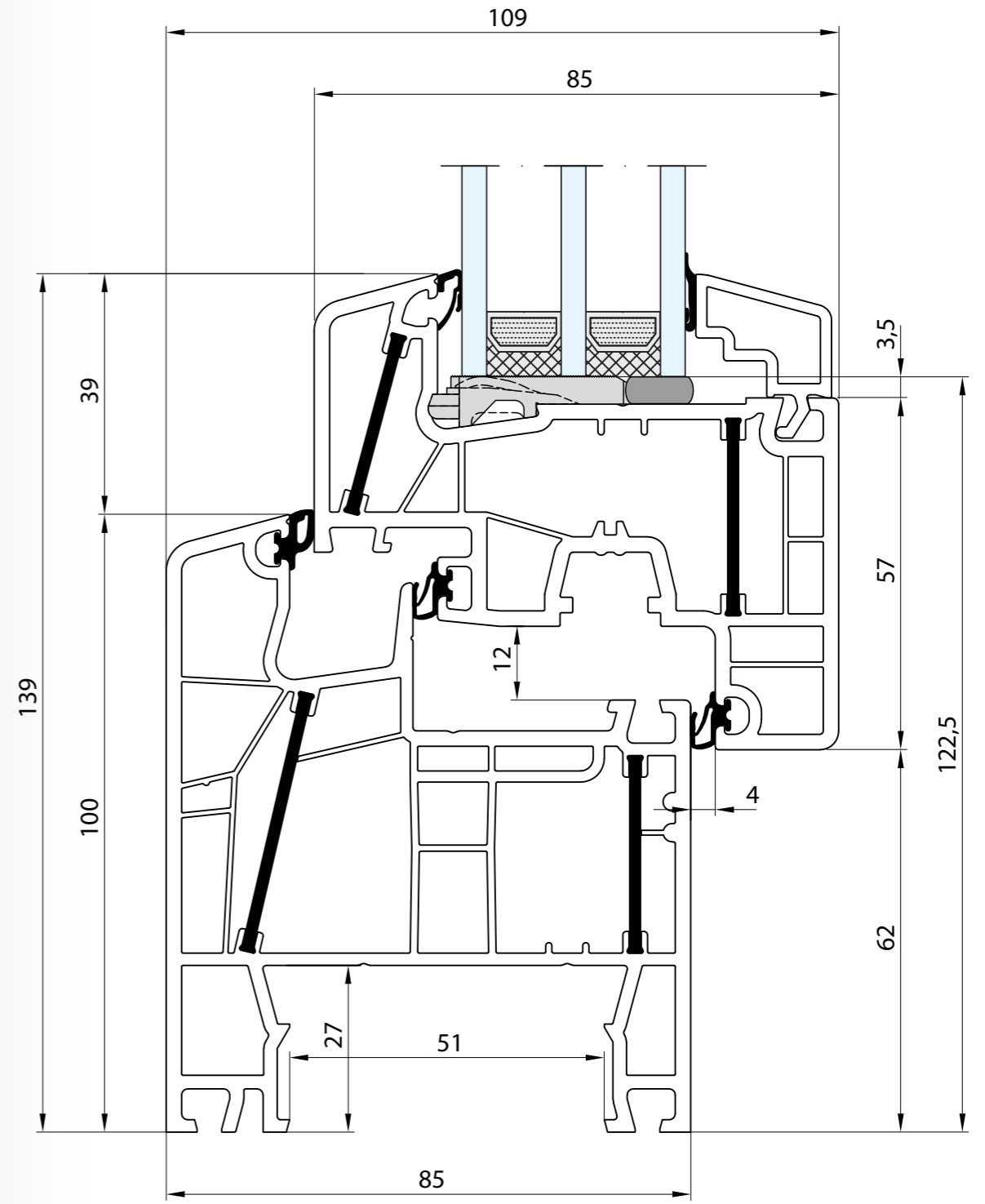
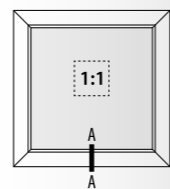

- Rama: 100 mm · Skrzydło: 77 mm
- Dormant: 100 mm · Vantail: 77 mm
- Frame: 100 mm · Sash: 77 mm
- Rahmen: 100 mm · Flügel: 77 mm
- Telaio: 100 mm · Anta: 77 mm

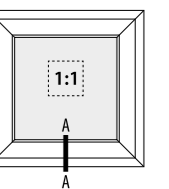

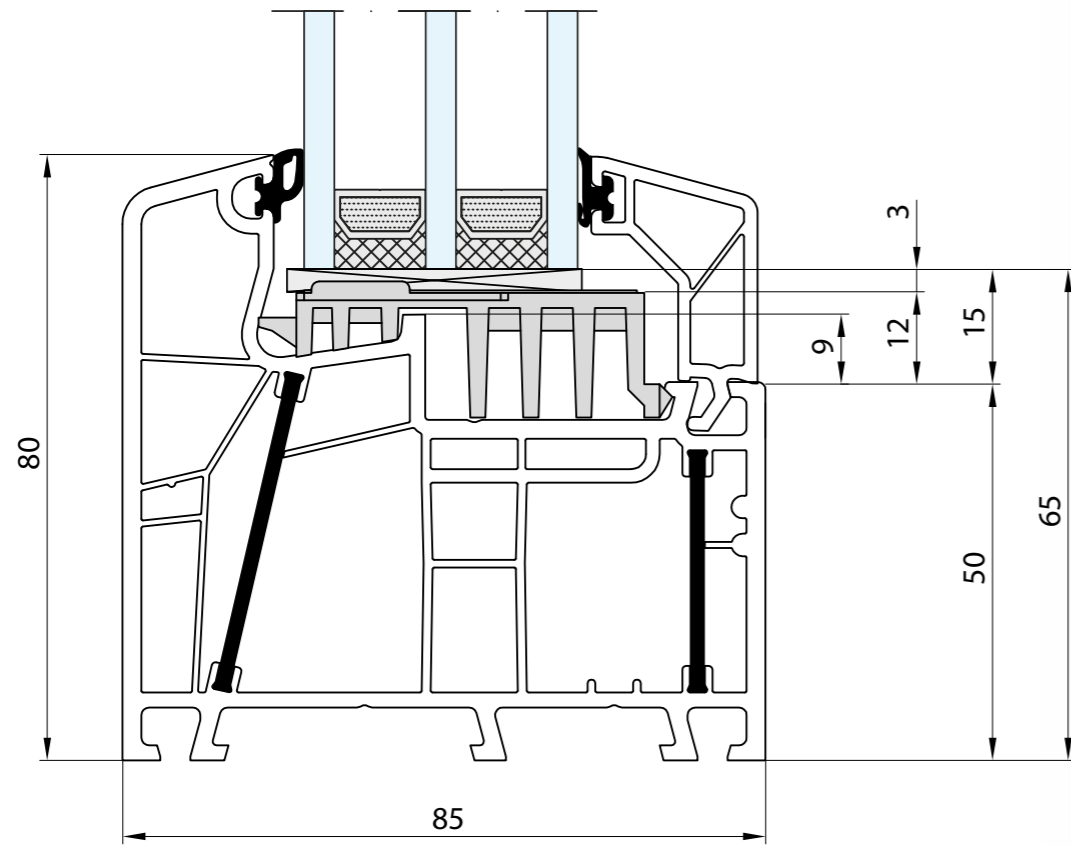
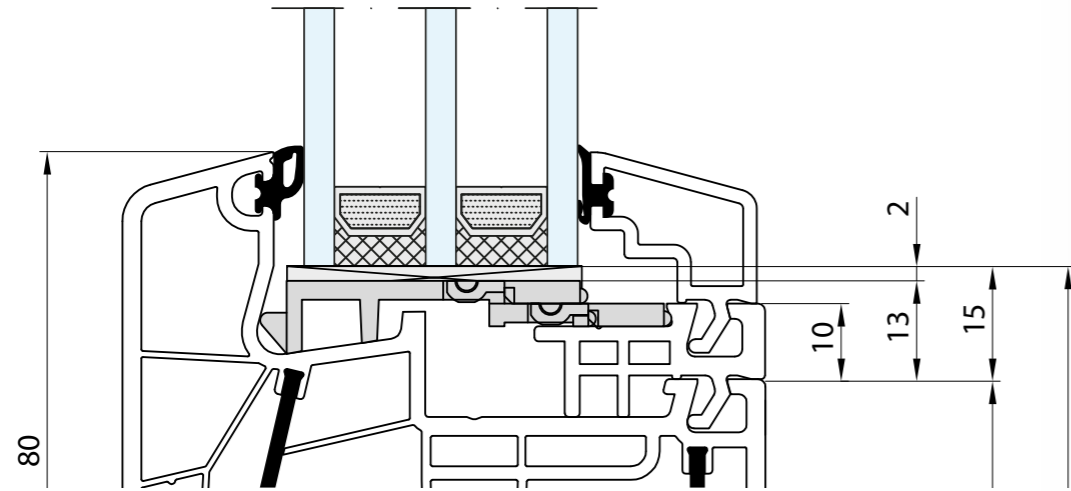

- Rama: 80 mm
- Dormant: 80 mm
- Frame: 80 mm
- Rahmen: 80 mm
- Telaio: 80 mm

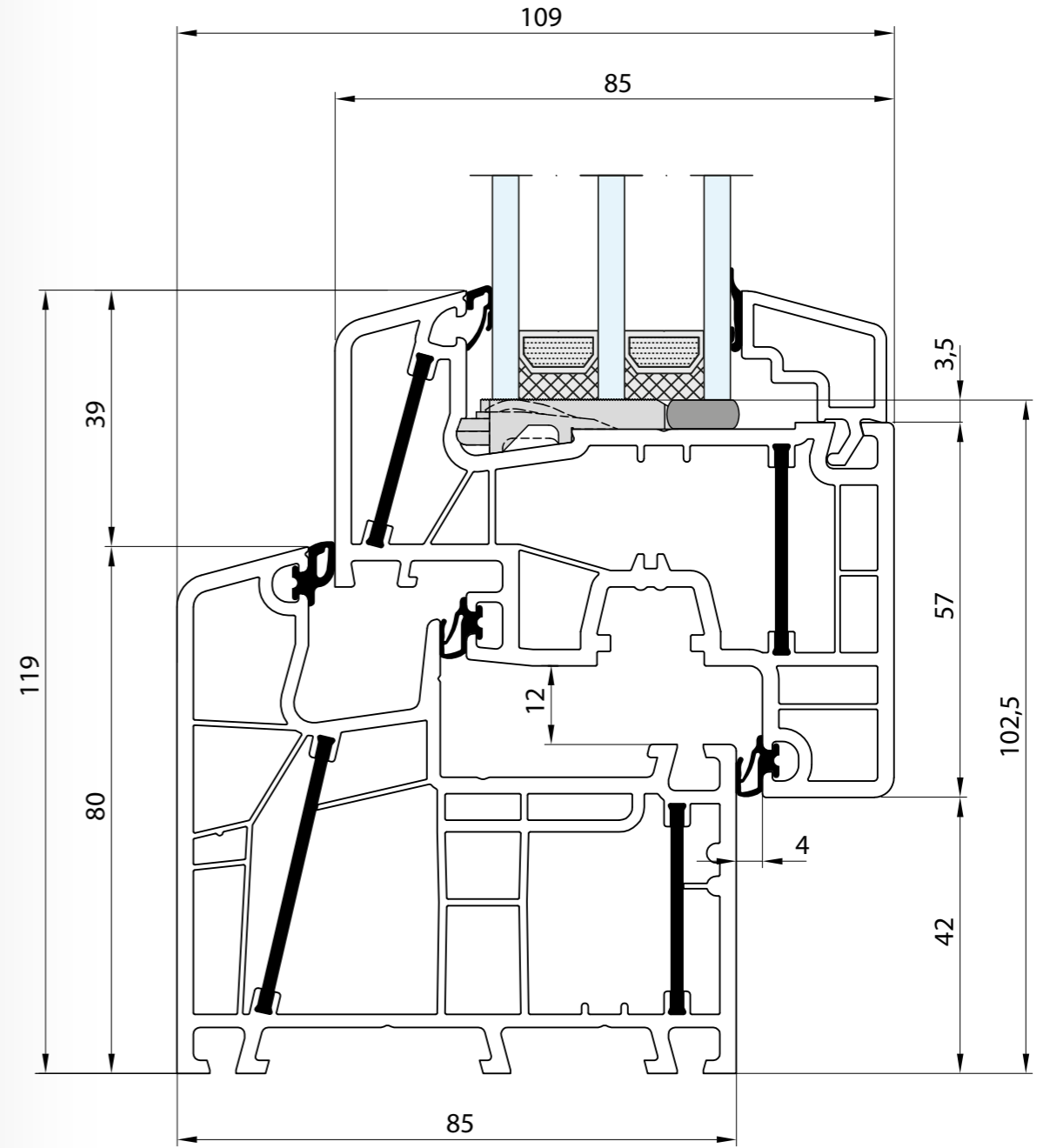
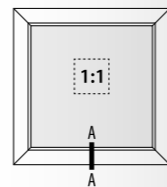

- Rama: 80 mm · Skrzydło: 77 mm
- Dormant: 80 mm · Vantail: 77 mm
- Frame: 80 mm · Sash: 77 mm
- Rahmen: 80 mm · Flügel: 77 mm
- Telaio: 80 mm · Anta: 77 mm

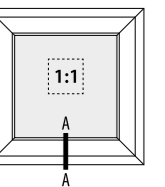

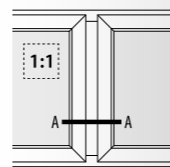
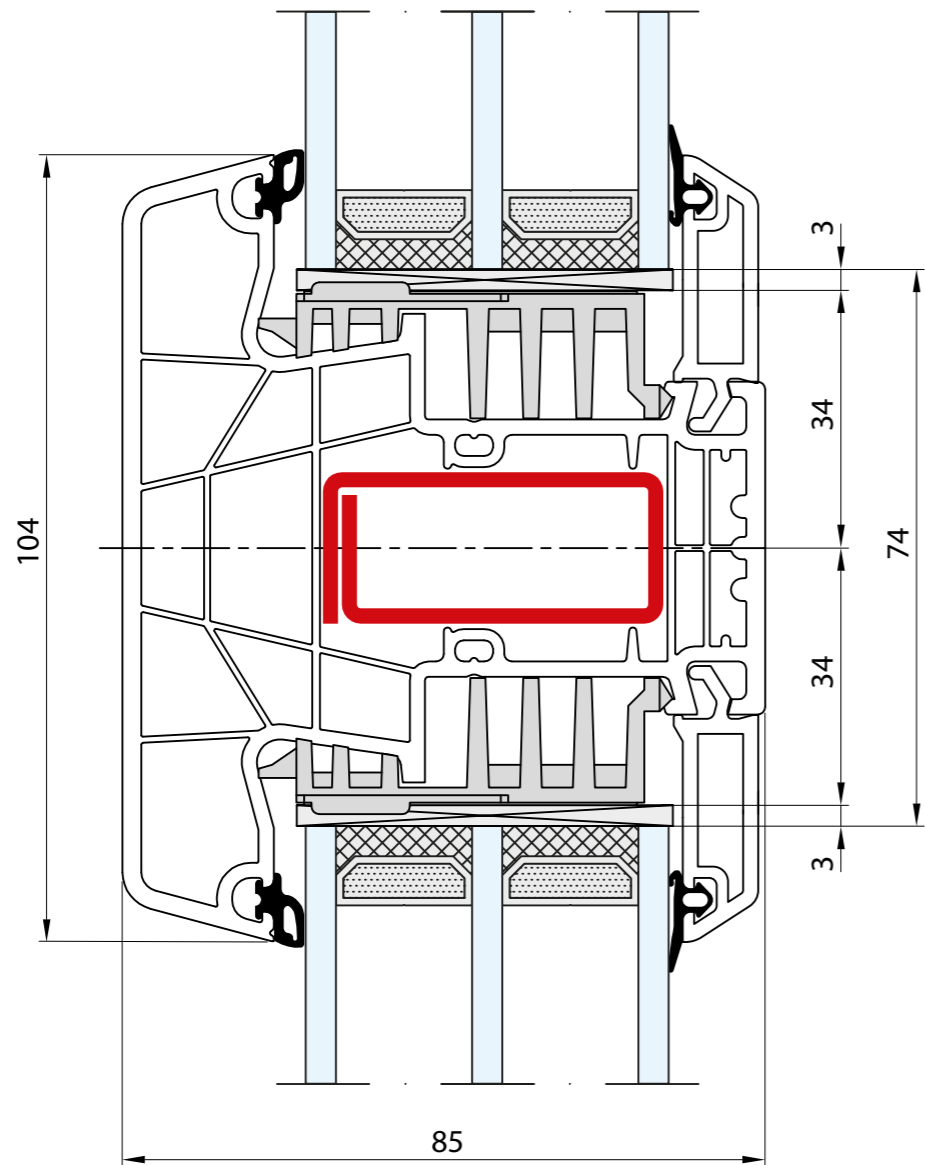

- Słupek stały: 104 mm
- Meneau fixe: 104 mm
- Fix post: 104 mm
- Festem Pfahl: 104 mm
- Montante fisso: 104 mm

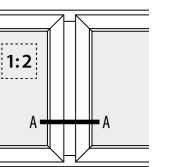
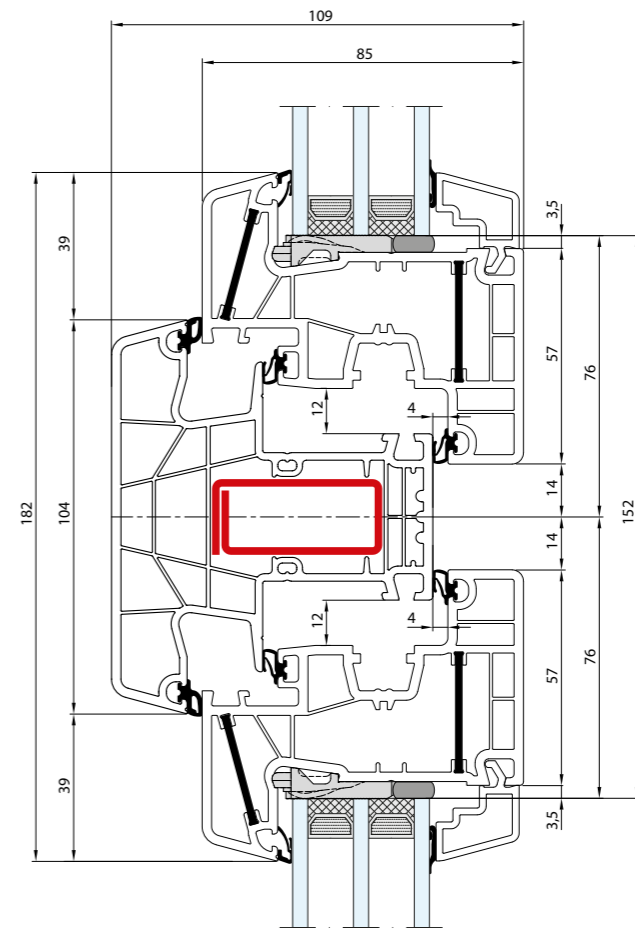

- Słupek stały: 104 mm · Skrzydło: 77 mm
- Meneau fixe: 104 mm · Vantail: 77 mm
- Fix post: 104 mm · Sash: 77 mm
- Festem Pfahl: 104 mm · Flügel: 77 mm
- Montante fisso: 104 mm · Anta: 77 mm

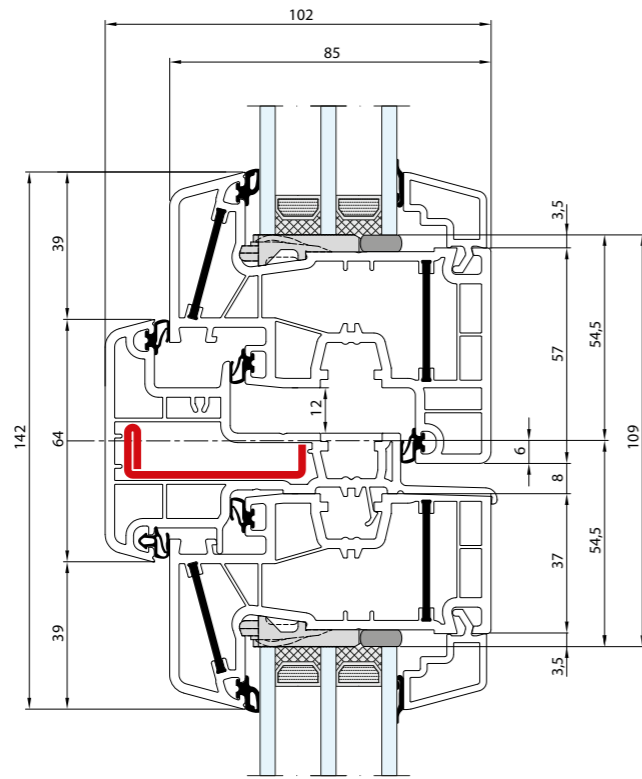

- Słupek ruchomy: 64 mm · Skrzydło: 77 mm / 57 mm
- Meneau mobile: 64 mm · Vantail: 77 mm / 57 mm
- Movable post: 64 mm · Sash: 77 mm / 57 mm
- Stulp: 64 mm · Flügel: 77 mm / 57 mm
- Montante mobile: 64 mm · Anta: 77 mm / 57 mm

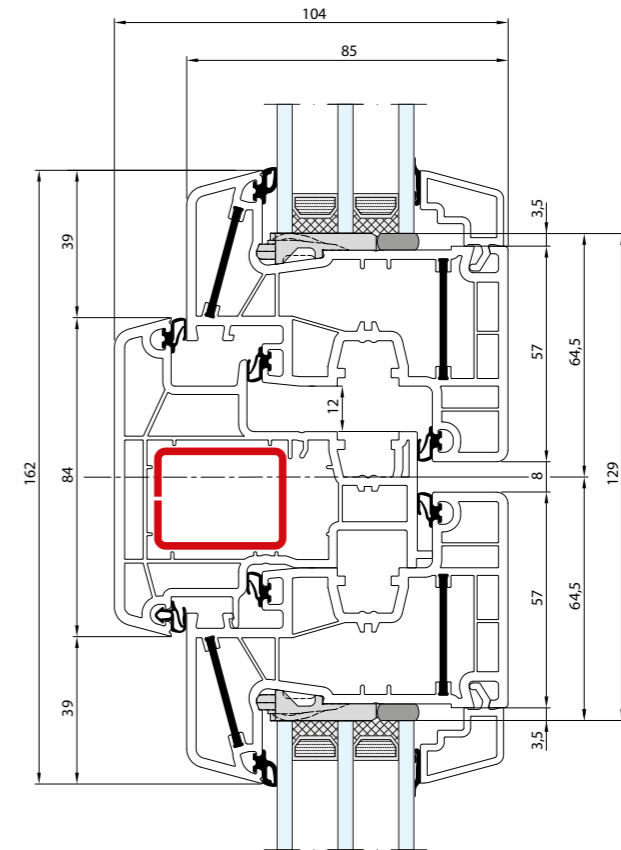
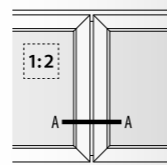

- Słupek ruchomy: 84 mm · Skrzydło: 77 mm
- Meneau mobile: 84 mm · Vantail: 77 mm
- Movable post: 84 mm · Sash: 77 mm
- Stulp: 84 mm · Flügel: 77 mm
- Montante mobile: 84 mm · Anta: 77 mm

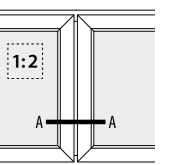

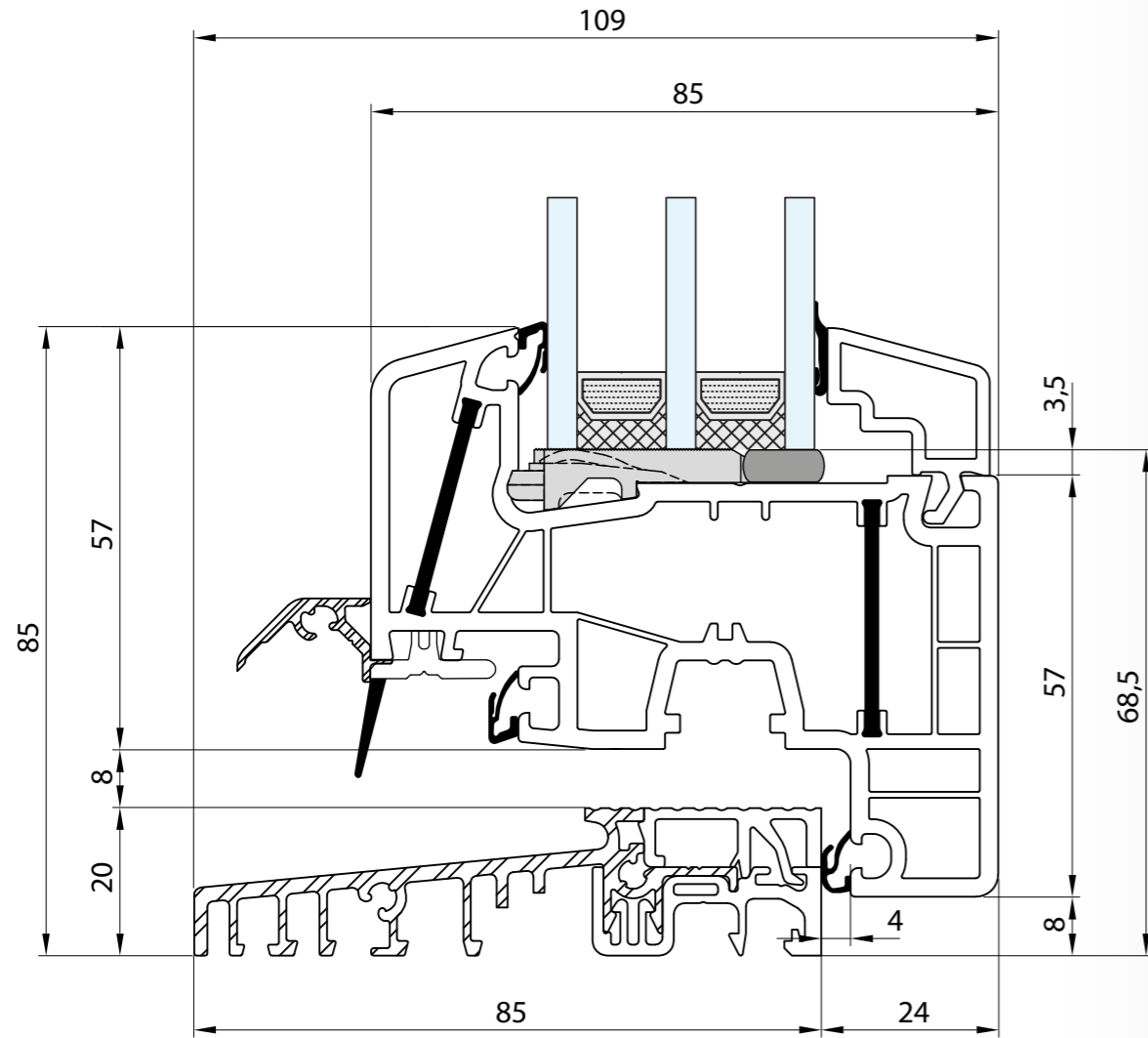

- Próg: 20 mm · Skrzydło: 77 mm
- Seuil: 20 mm · Vantail: 77 mm
- Threshold: 20 mm · Sash: 77 mm
- Schwelle: 20 mm · Flügel: 77 mm
- Soglia: 20 mm · Anta: 77 mm

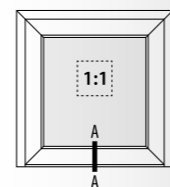

BLOCKPROFIL NL

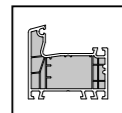

3



2

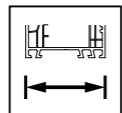

120

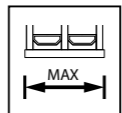

42



SUPER SOLUTION



HFL

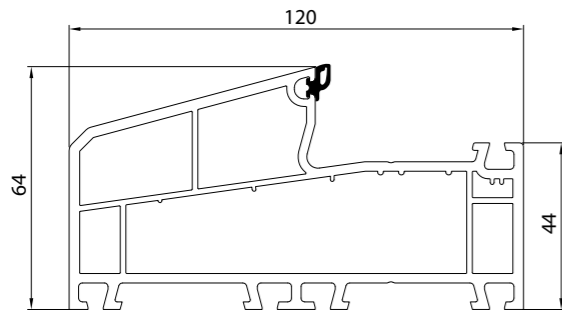

SL A* 140x53

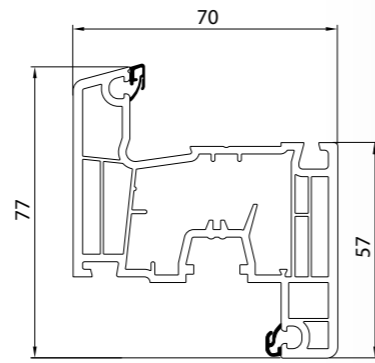

CL ALU 140x20

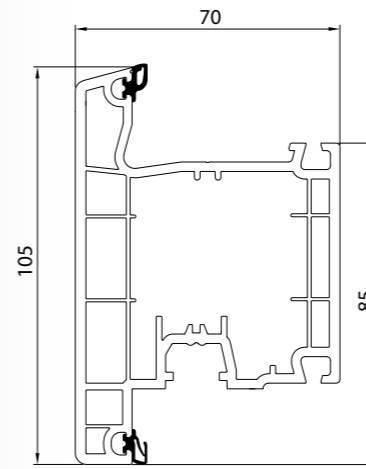

CL 140x31

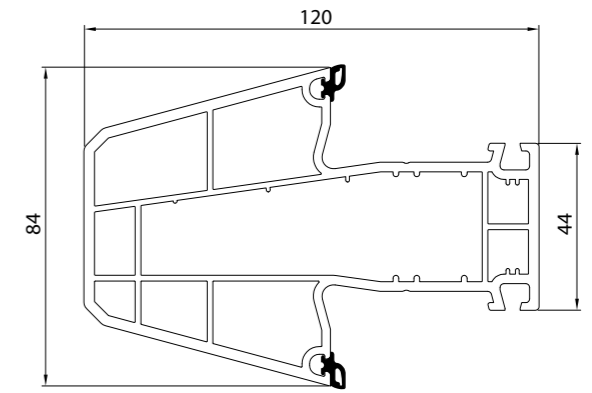

SL 140x57

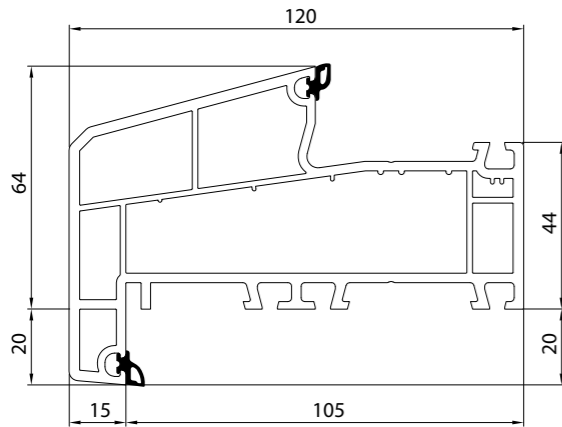

SL A* 140x54

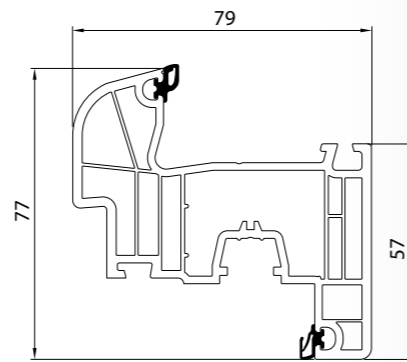

RL 140x22

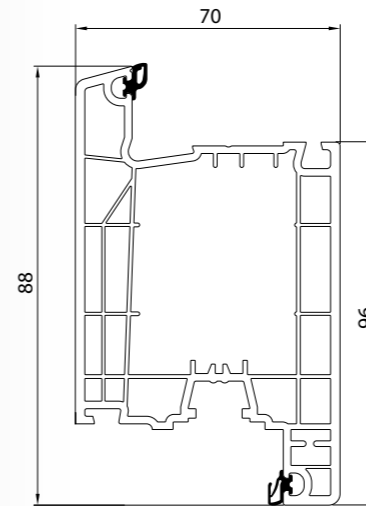

CL ALU 140x33

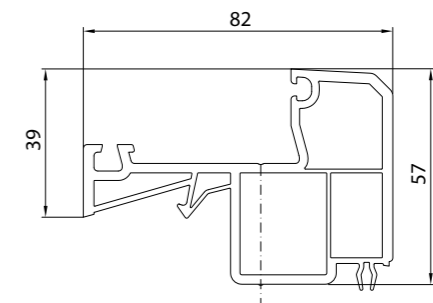

SL 140x58

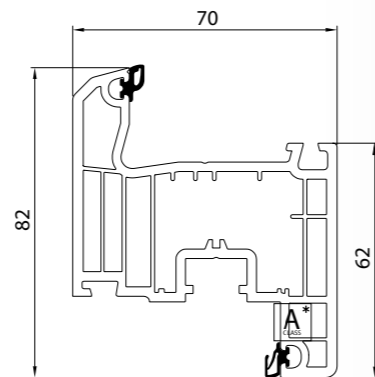

CL A* ALU 140x23

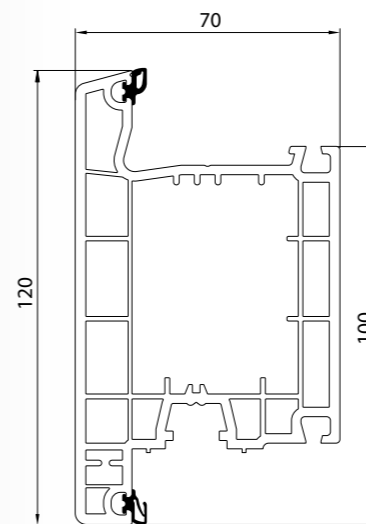

CL 140x35

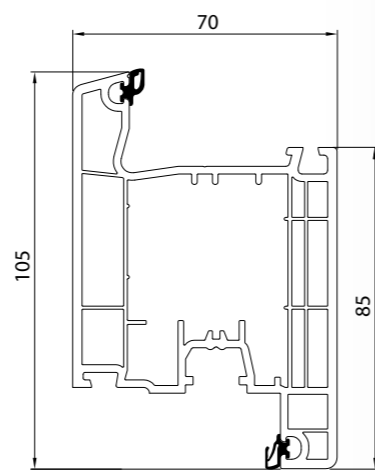

CL ALU 140x30

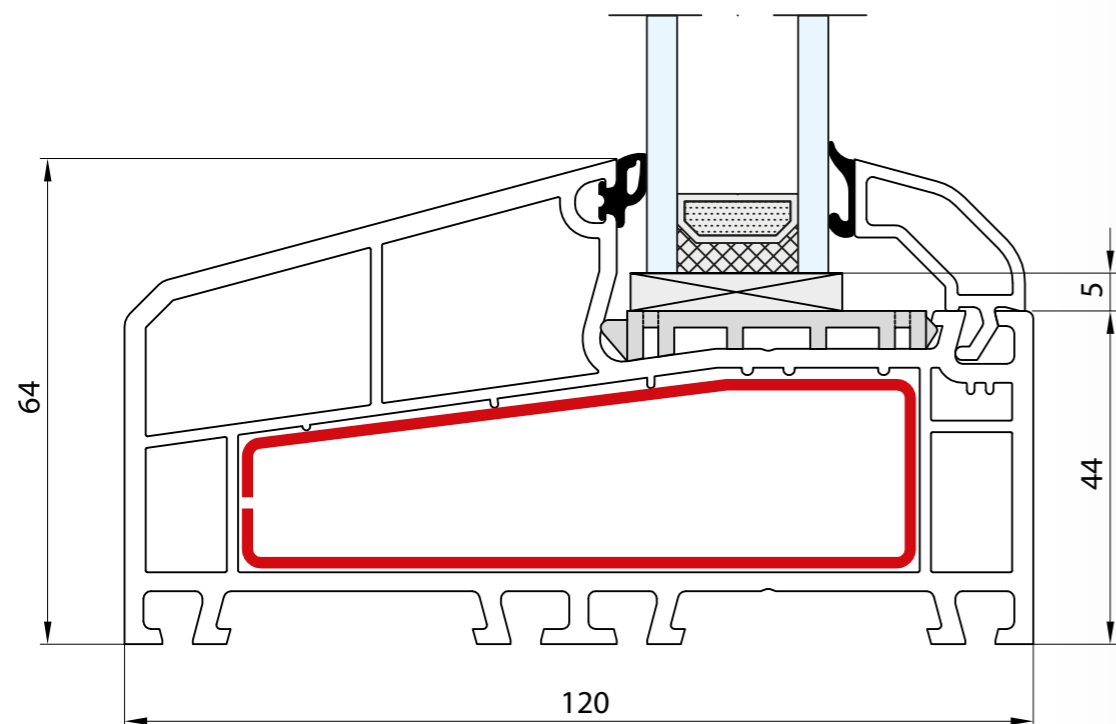

- Rama: 64 mm
- Dormant: 64 mm
- Frame: 64 mm
- Rahmen: 64 mm
- Telaio: 64 mm

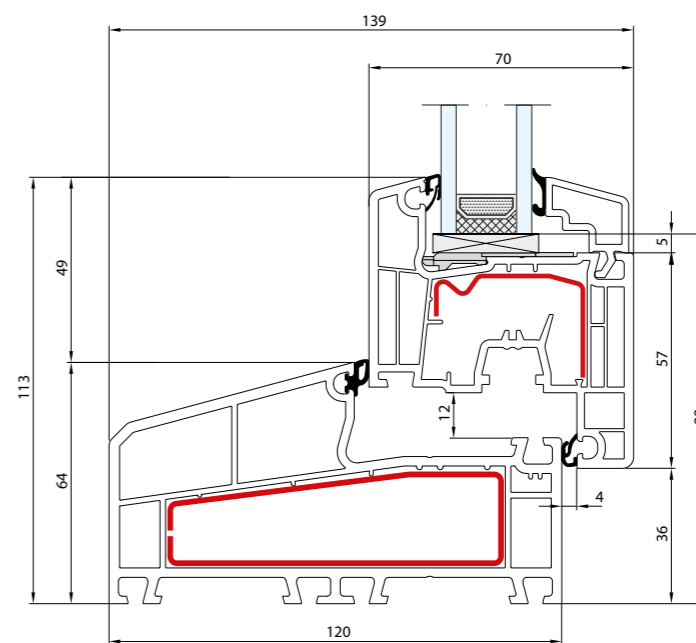
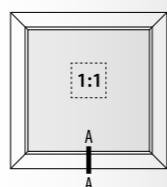

- Rama: 64 mm · Skrzydło: 77 mm
- Dormant: 64 mm · Vantail: 77 mm
- Frame: 64 mm · Sash: 77 mm
- Rahmen: 64 mm · Flügel: 77 mm
- Telaio: 64 mm · Anta: 77 mm

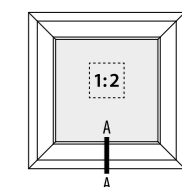

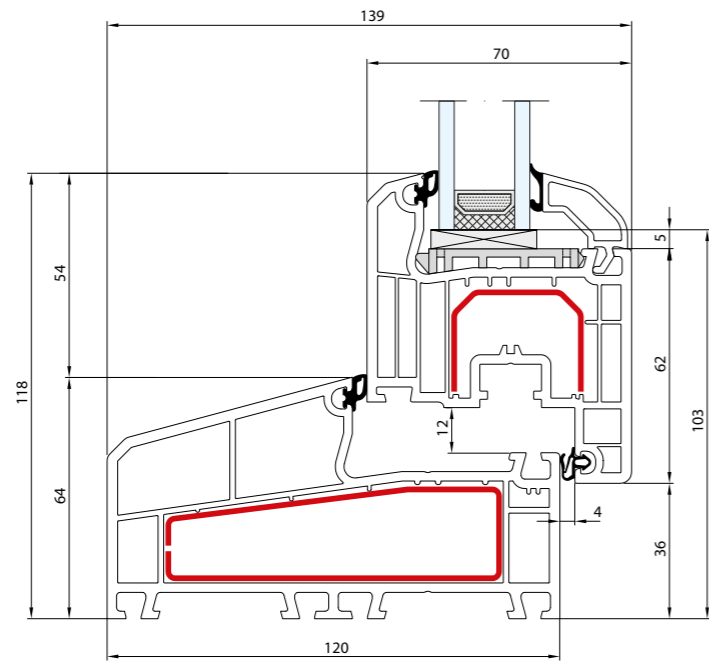

- Rama: 64 mm · Skrzydło: 82 mm
- Dormant: 64 mm · Vantail: 82 mm
- Frame: 64 mm · Sash: 82 mm
- Rahmen: 64 mm · Flügel: 82 mm
- Telaio: 64 mm · Anta: 82 mm

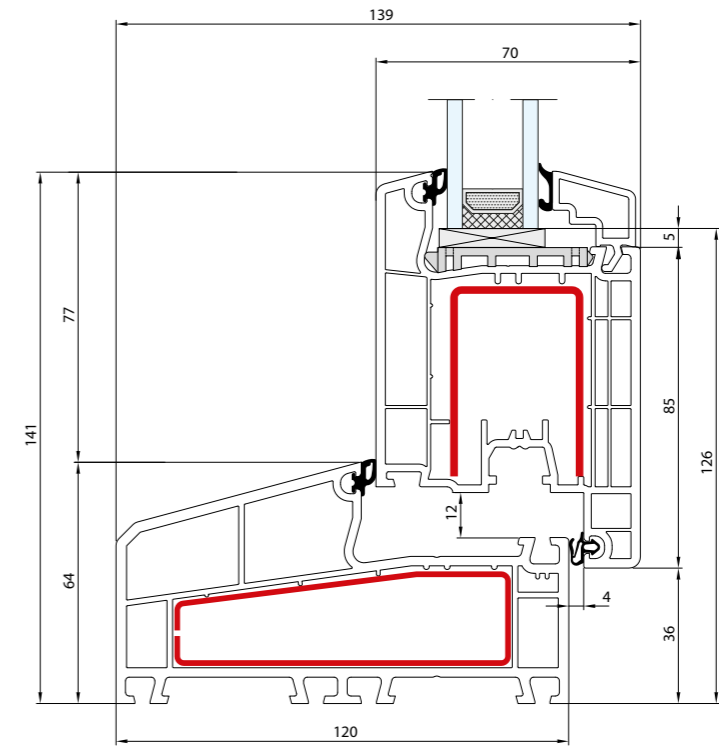
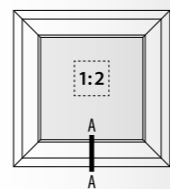

- Rama: 64 mm · Skrzydło: 105 mm
- Dormant: 64 mm · Vantail: 105 mm
- Frame: 64 mm · Sash: 105 mm
- Rahmen: 64 mm · Flügel: 105 mm
- Telaio: 64 mm · Anta: 105 mm

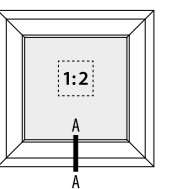

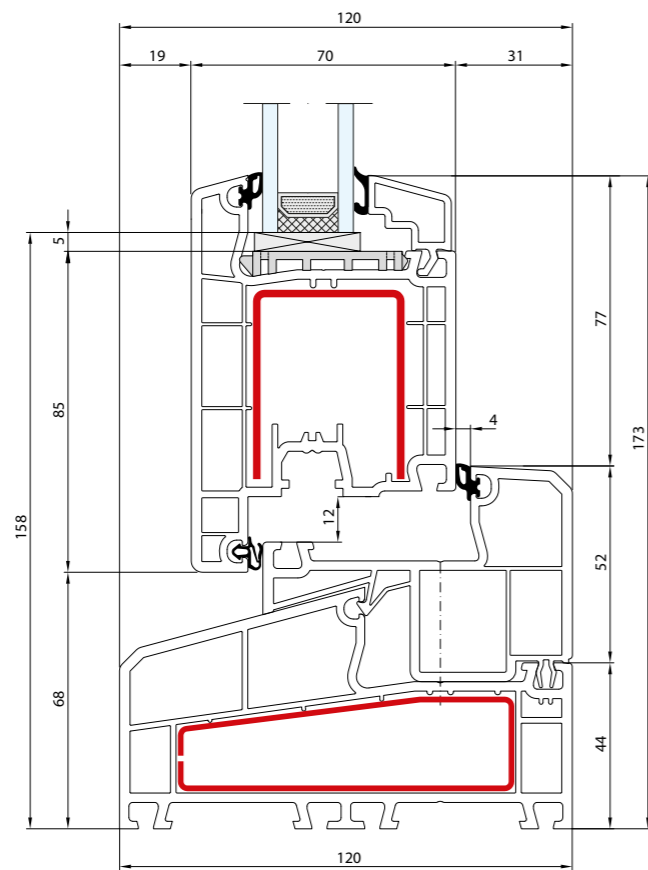

- Rama: 68 mm · Skrzydło: 105 mm
- Dormant: 68 mm · Vantail: 105 mm
- Frame: 68 mm · Sash: 105 mm
- Rahmen: 68 mm · Flügel: 105 mm
- Telaio: 68 mm · Anta: 105 mm

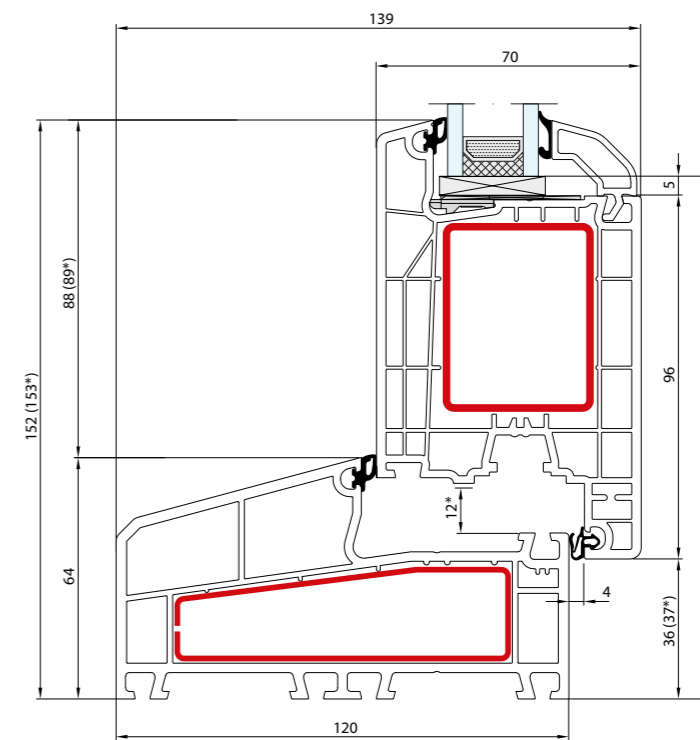
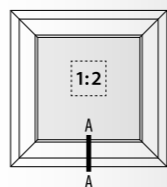

- Rama: 64 mm · Skrzydło: 116 mm
- Dormant: 64 mm · Vantail: 116 mm
- Frame: 64 mm · Sash: 116 mm
- Rahmen: 64 mm · Flügel: 116 mm
- Telaio: 64 mm · Anta: 116 mm

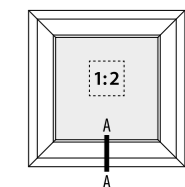

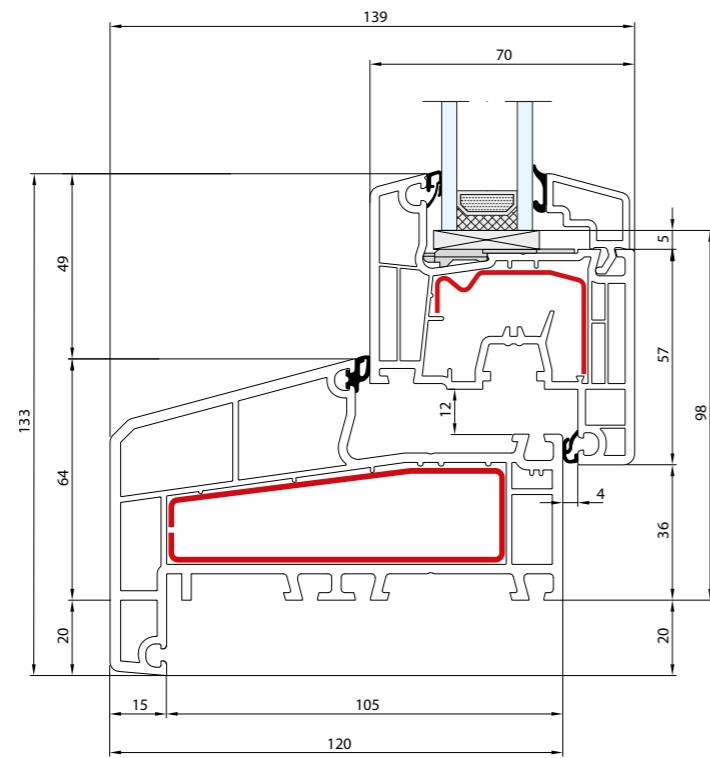

- Rama: 84 mm · Skrzydło: 77 mm
- Dormant: 84 mm · Vantail: 77 mm
- Frame: 84 mm · Sash: 77 mm
- Rahmen: 84 mm · Flügel: 77 mm
- Telaio: 84 mm · Anta: 77 mm

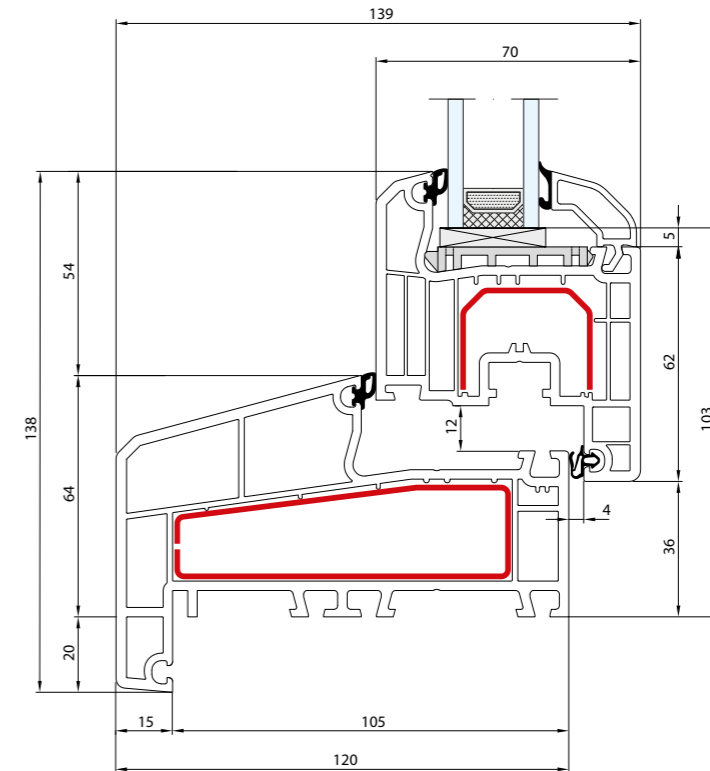
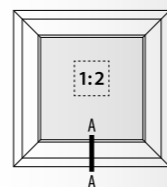

- Rama: 84 mm · Skrzydło: 82 mm
- Dormant: 84 mm · Vantail: 82 mm
- Frame: 84 mm · Sash: 82 mm
- Rahmen: 84 mm · Flügel: 82 mm
- Telaio: 84 mm · Anta: 82 mm

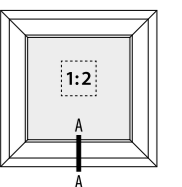

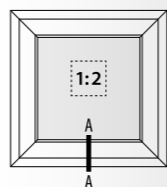
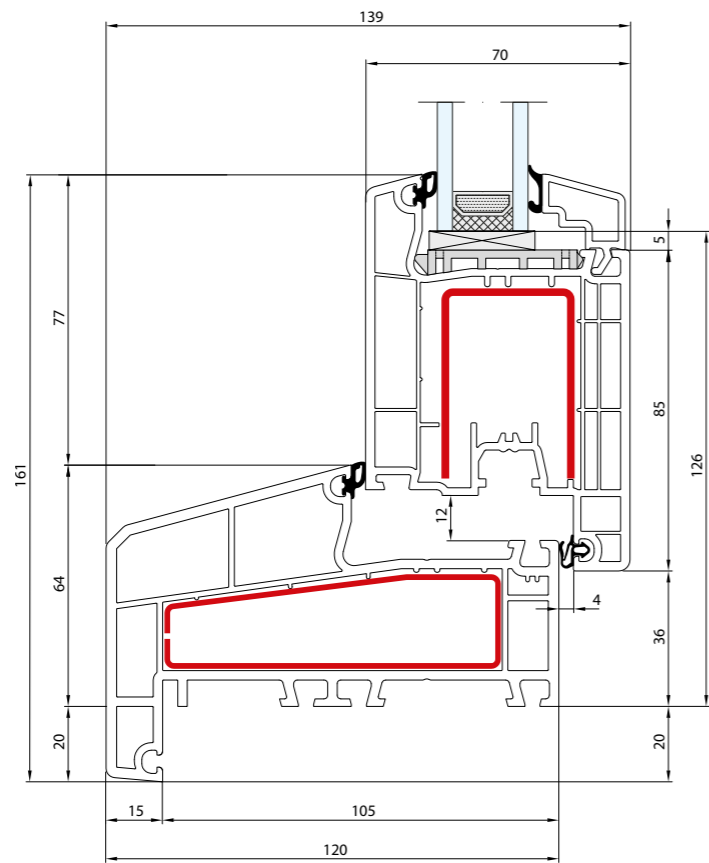

- Rama: 84 mm · Skrzydło: 105 mm
- Dormant: 84 mm · Vantail: 105 mm
- Frame: 84 mm · Sash: 105 mm
- Rahmen: 84 mm · Flügel: 105 mm
- Telaio: 84 mm · Anta: 105 mm

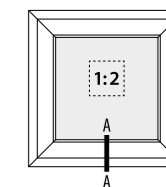
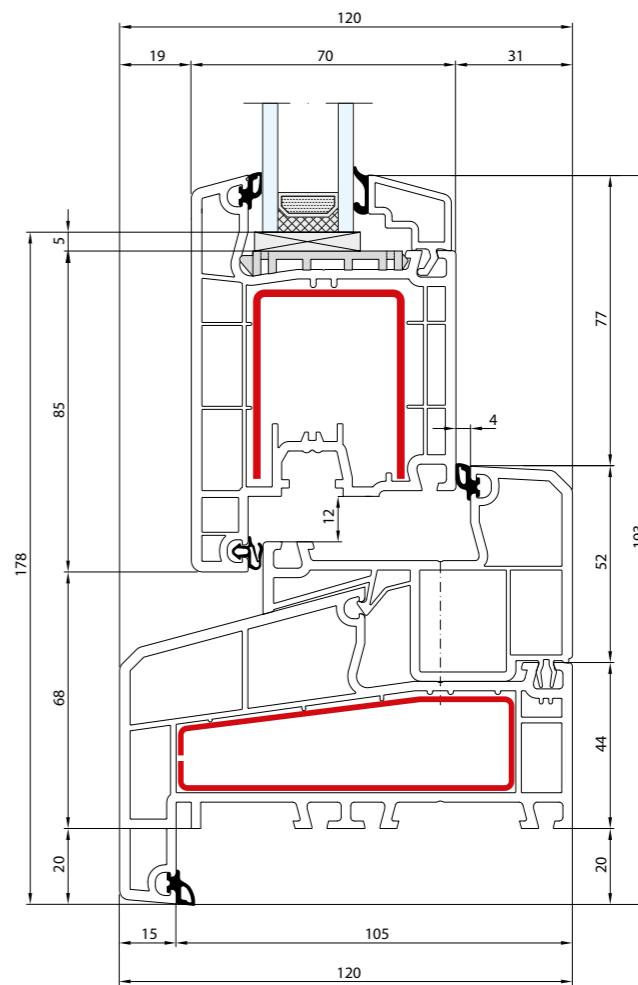

- Rama: 88 mm · Skrzydło: 105 mm
- Dormant: 88 mm · Vantail: 105 mm
- Frame: 88 mm · Sash: 105 mm
- Rahmen: 88 mm · Flügel: 105 mm
- Telaio: 88 mm · Anta: 105 mm

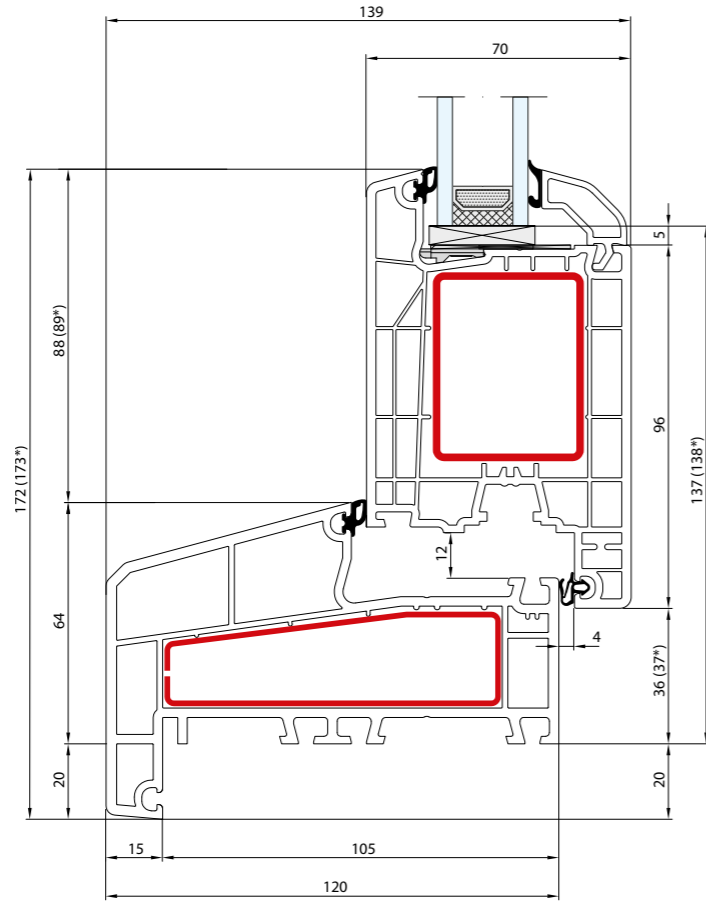

- Rama: 84 mm · Skrzydło: 116 mm
- Dormant: 84 mm · Vantail: 116 mm
- Frame: 84 mm · Sash: 116 mm
- Rahmen: 84 mm · Flügel: 116 mm
- Telaio: 84 mm · Anta: 116 mm

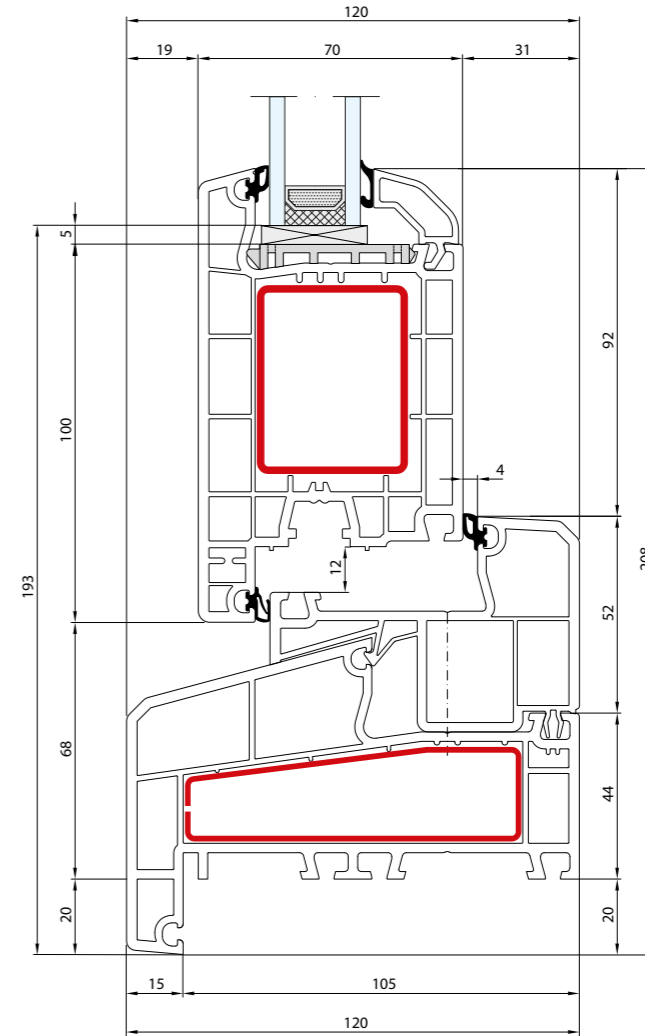
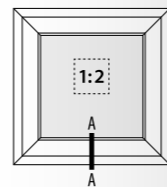

- Rama: 88 mm · Skrzydło: 120 mm
- Dormant: 88 mm · Vantail: 120 mm
- Frame: 88 mm · Sash: 120 mm
- Rahmen: 88 mm · Flügel: 120 mm
- Telaio: 88 mm · Anta: 120 mm

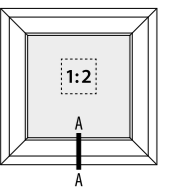

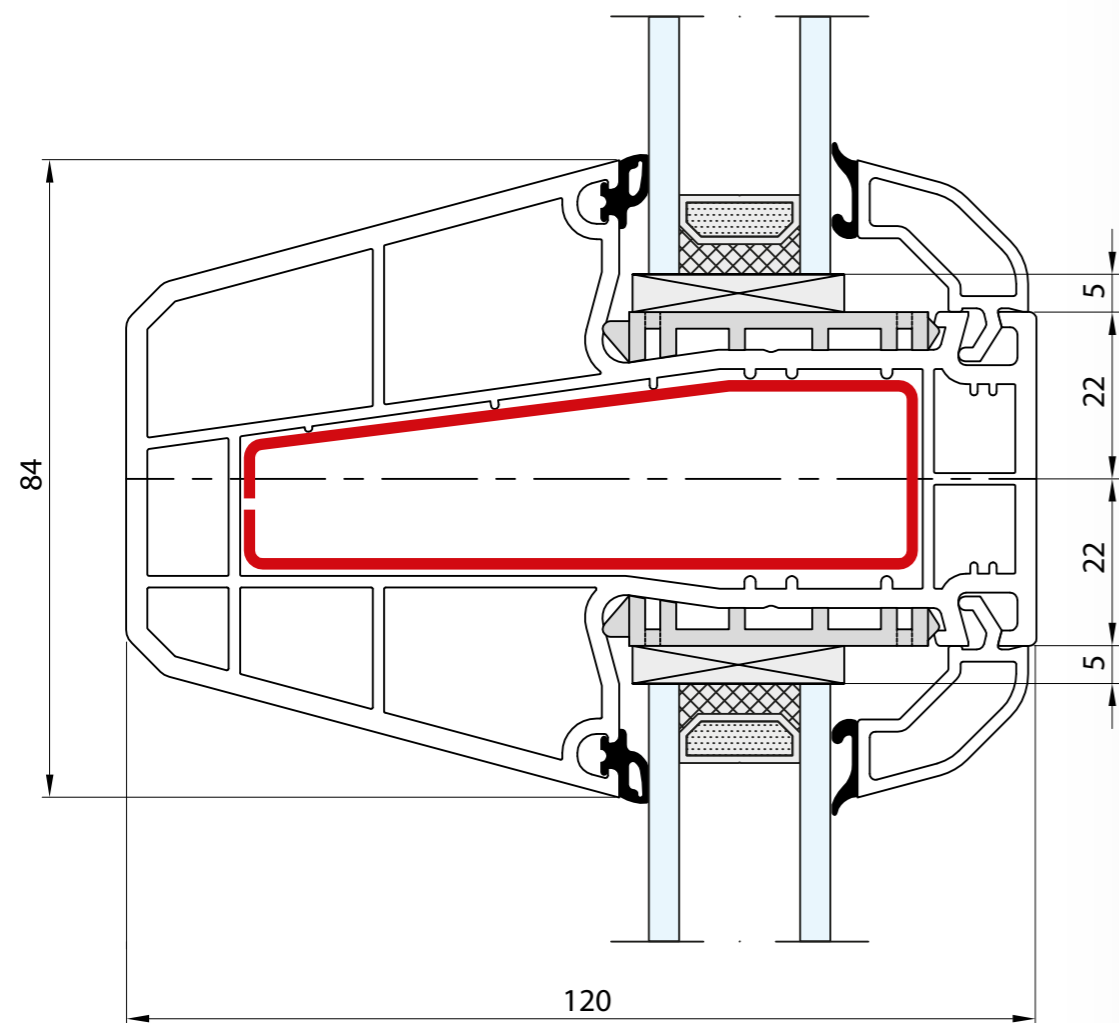

- Słupek stały: 84 mm
- Meneau fixe: 84 mm
- Fix post: 84 mm
- Festem Pfahl: 84 mm
- Montante fisso: 84 mm

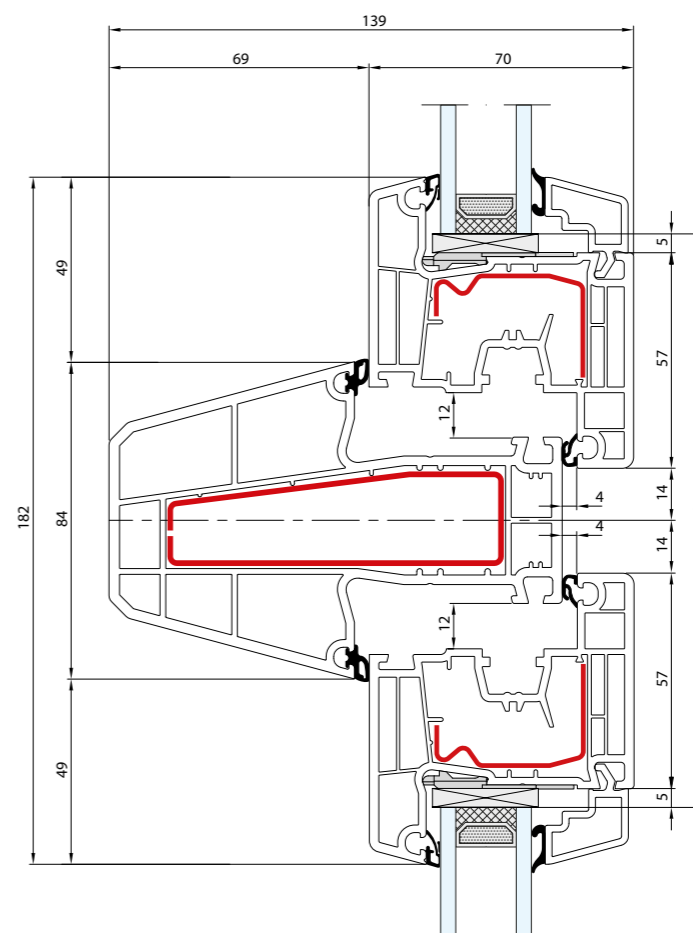
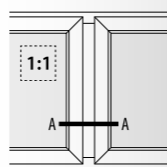

- Słupek stały: 84 mm · Skrzydło: 77 mm
- Meneau fixe: 84 mm · Vantail: 77 mm
- Fix post: 84 mm · Sash: 77 mm
- Festem Pfahl: 84 mm · Flügel: 77 mm
- Montante fisso: 84 mm · Anta: 77 mm

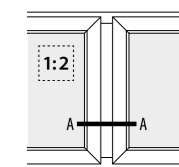

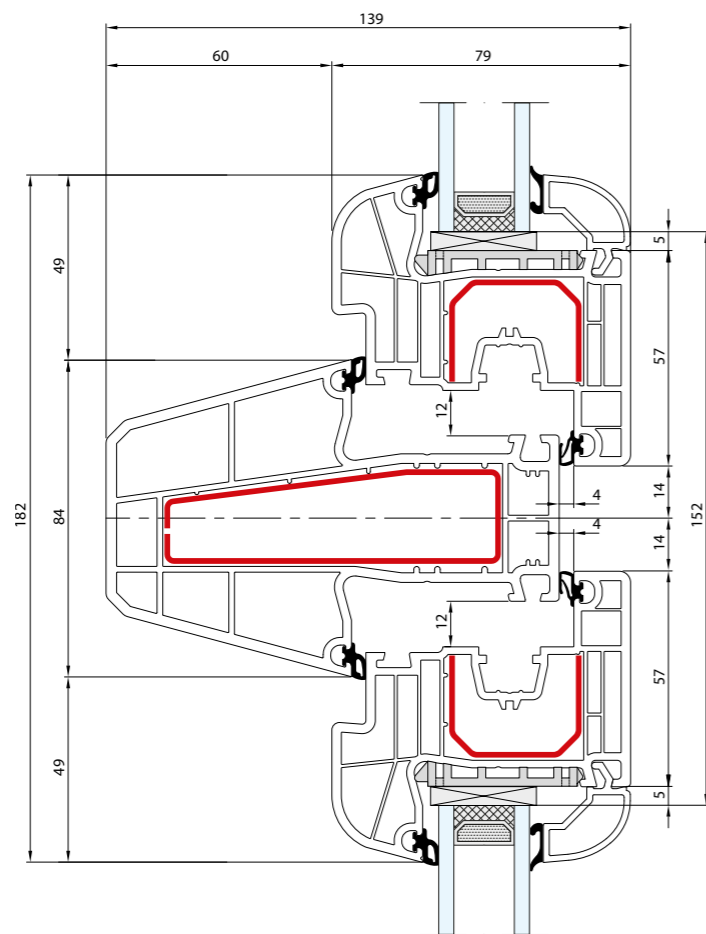

- Słupek stały: 84 mm · Skrzydło: 77 mm
- Meneau fixe: 84 mm · Vantail: 77 mm
- Fix post: 84 mm · Sash: 77 mm
- Festem Pfahl: 84 mm · Flügel: 77 mm
- Montante fisso: 84 mm · Anta: 77 mm

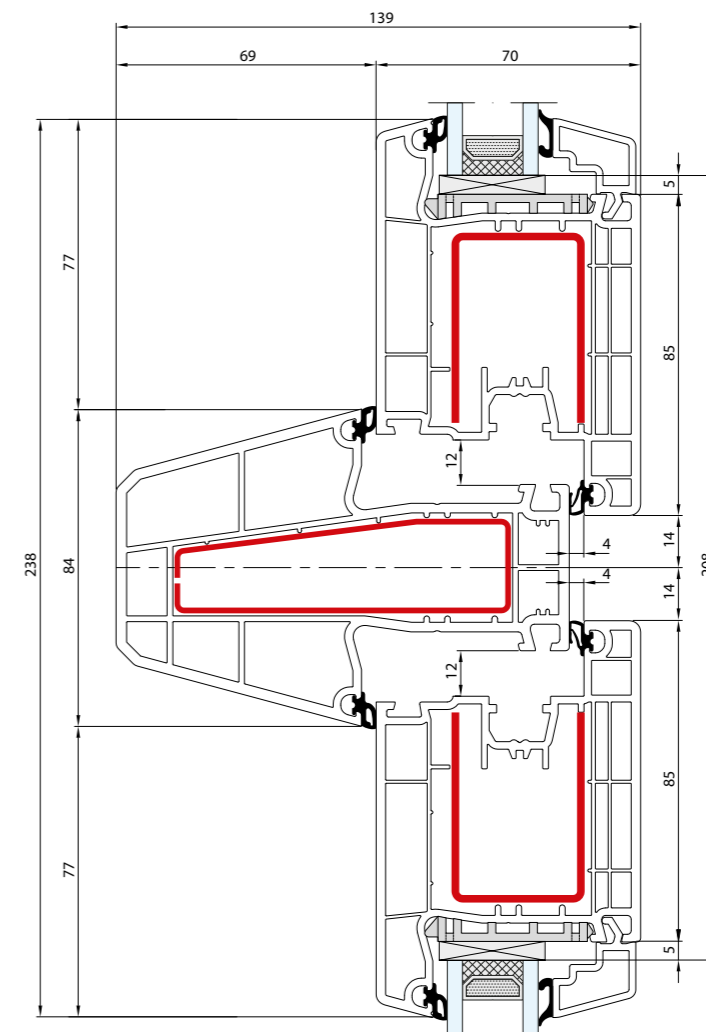
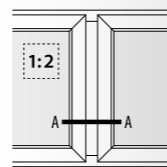

- Słupek stały: 84 mm · Skrzydło: 105 mm
- Meneau fixe: 84 mm · Vantail: 105 mm
- Fix post: 84 mm · Sash: 105 mm
- Festem Pfahl: 84 mm · Flügel: 105 mm
- Montante fisso: 84 mm · Anta: 105 mm

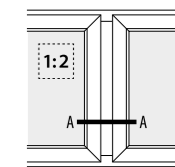

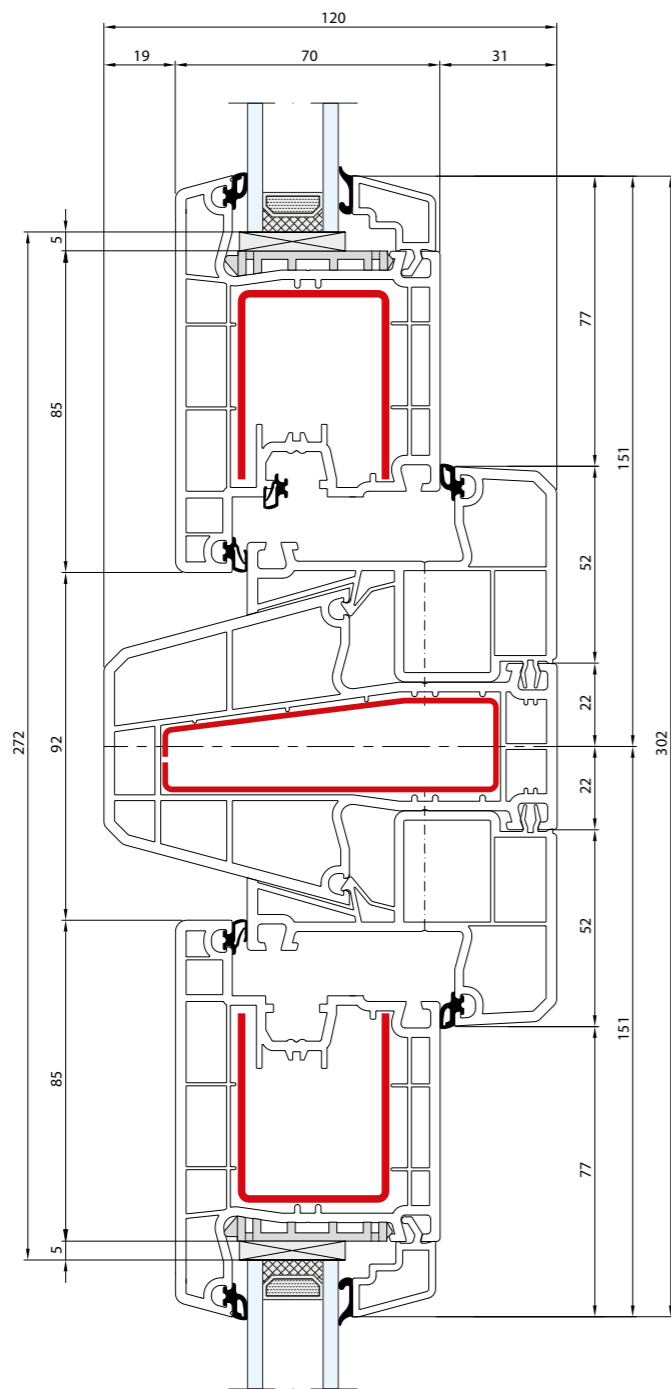

- Słupek stały: 84 mm · Skrzydło: 105 mm
- Meneau fixe: 84 mm · Vantail: 105 mm
- Fix post: 84 mm · Sash: 105 mm
- Festem Pfahl: 84 mm · Flügel: 105 mm
- Montante fisso: 84 mm · Anta: 105 mm

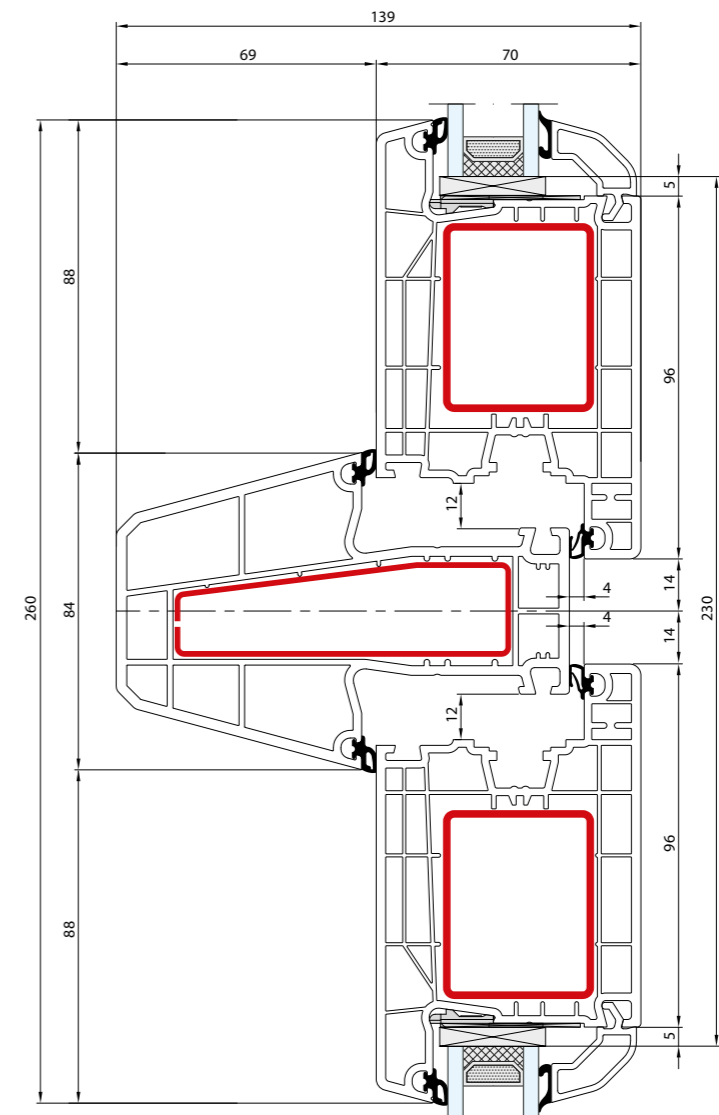
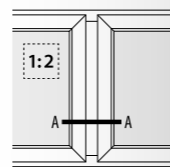

- Słupek stały: 84 mm · Skrzydło: 116 mm
- Meneau fixe: 84 mm · Vantail: 116 mm
- Fix post: 84 mm · Sash: 116 mm
- Festem Pfahl: 84 mm · Flügel: 116 mm
- Montante fisso: 84 mm · Anta: 116 mm

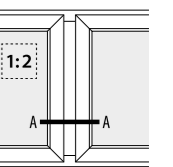

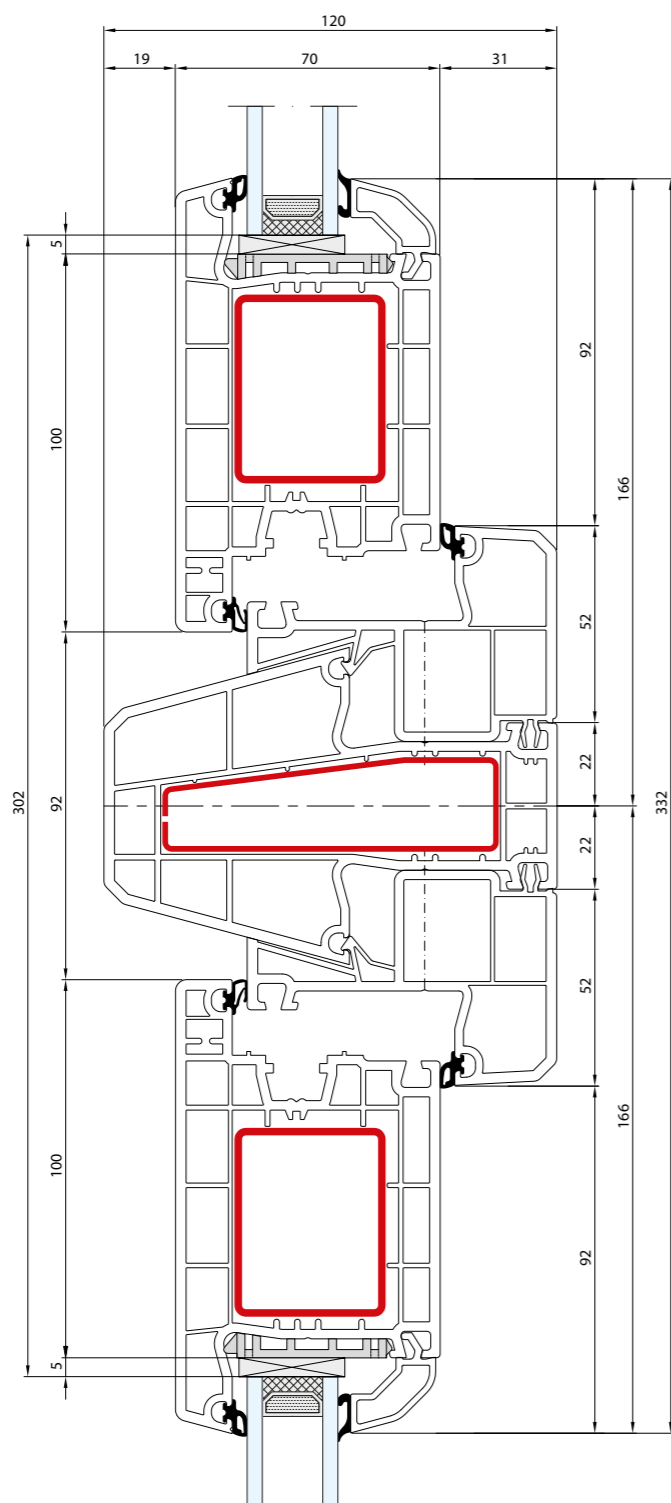



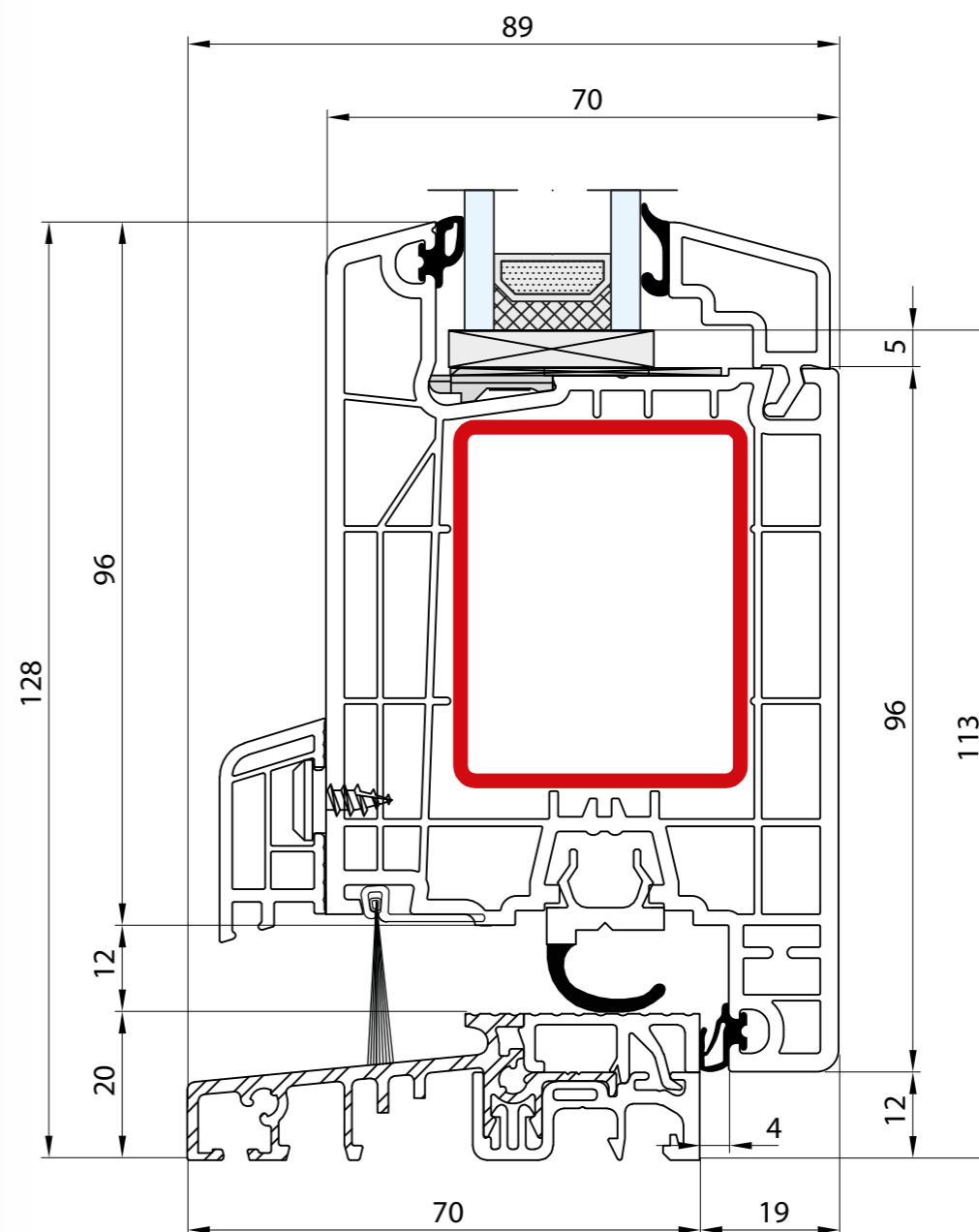
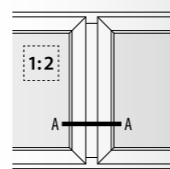

- Słupek stały: 84 mm · Skrzydło: 120 mm
- Meneau fixe: 84 mm · Vantail: 120 mm
- Fix post: 84 mm · Sash: 120 mm
- Festem Pfahl: 84 mm · Flügel: 120 mm
- Montante fisso: 84 mm · Anta: 120 mm

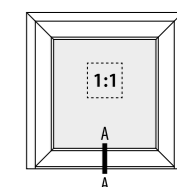

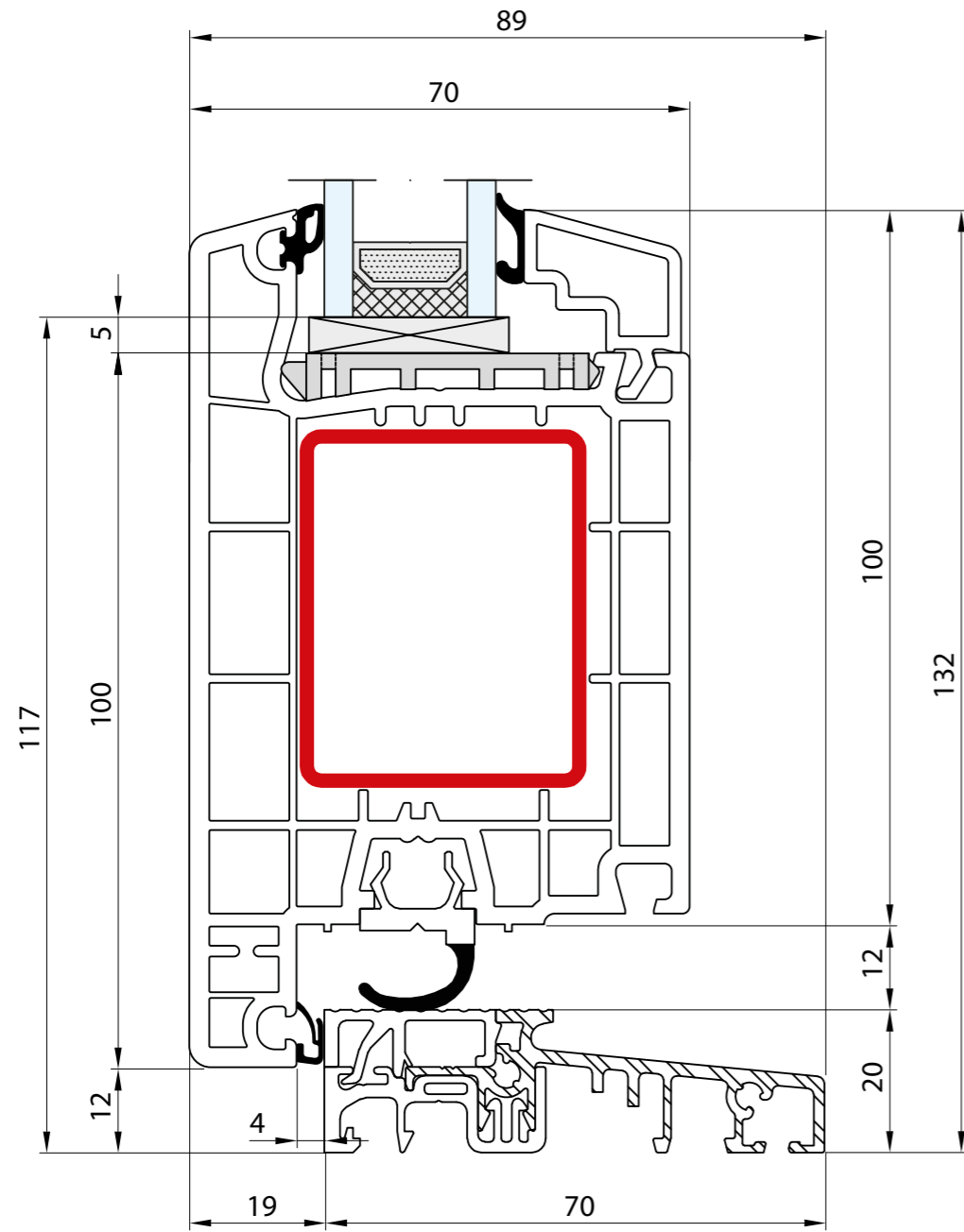
- Próg: 20 mm · Skrzydło: 116 mm
- Seuil: 20 mm · Vantail: 116 mm
- Threshold: 20 mm · Sash: 116 mm
- Schwelle: 20 mm · Flügel: 116 mm
- Soglia: 20 mm · Anta: 116 mm





-  Próg: 20 mm · Skrzydło: 120 mm
-  Seuil: 20 mm · Vantail: 120 mm
-  Threshold: 20 mm · Sash: 120 mm
-  Schwelle: 20 mm · Flügel: 120 mm
-  Soglia: 20 mm · Anta: 120 mm

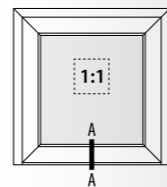

MONOBLOCK

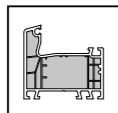

5



2

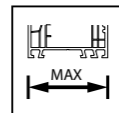

162

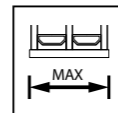

42

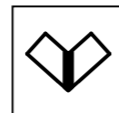

V SUPER SOLUTION

1:2



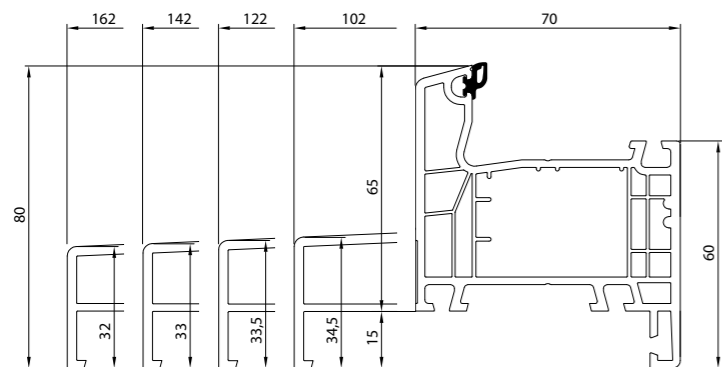

140x19 | 140x18 | 140x16 | 140x14 | 140x12

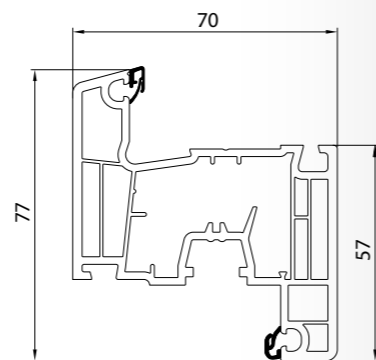

140x20

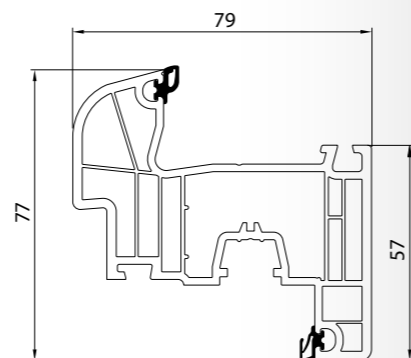

140x22

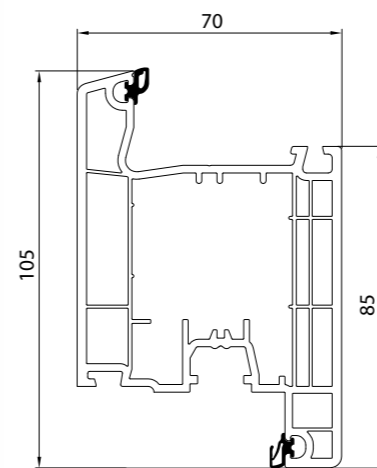

140x30

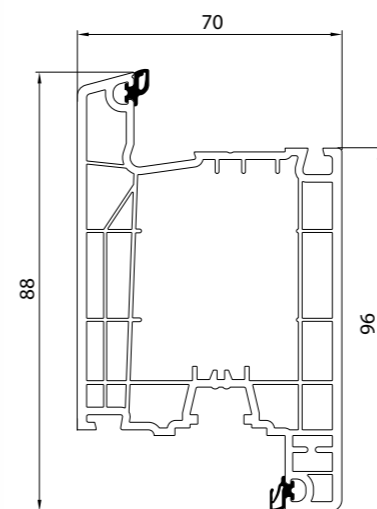

140x33

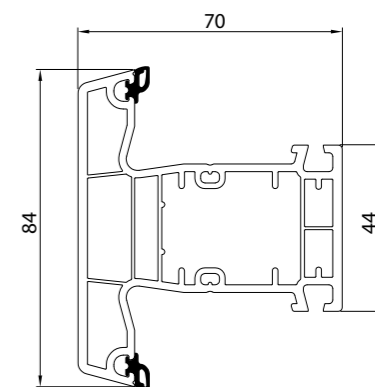

140x41

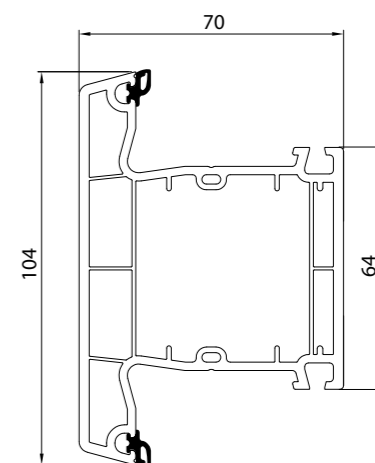

140x45

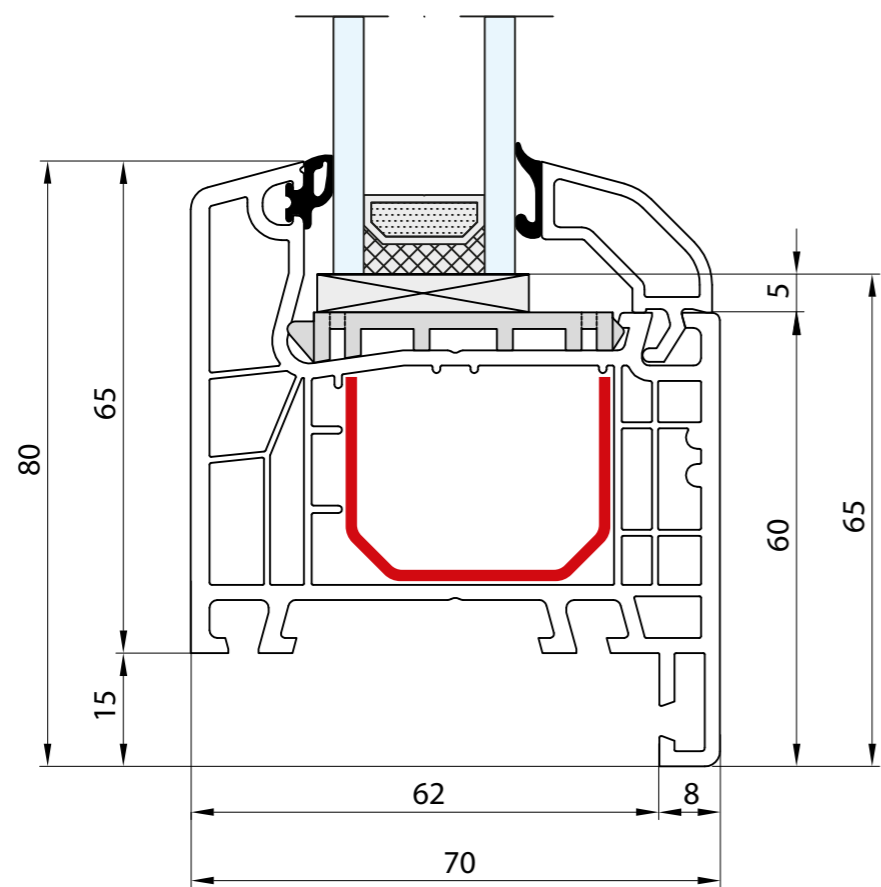

- MONOBLOCK - 70 mm · Rama: 80 mm
- MONOBLOC - 70 mm · Dormant: 80 mm
- MONOBLOK - 70 mm · Frame: 80 mm
- MONOBLOCK - 70 mm · Rahmen: 80 mm
- MONOBLOCK - 70 mm · Telaio: 80 mm

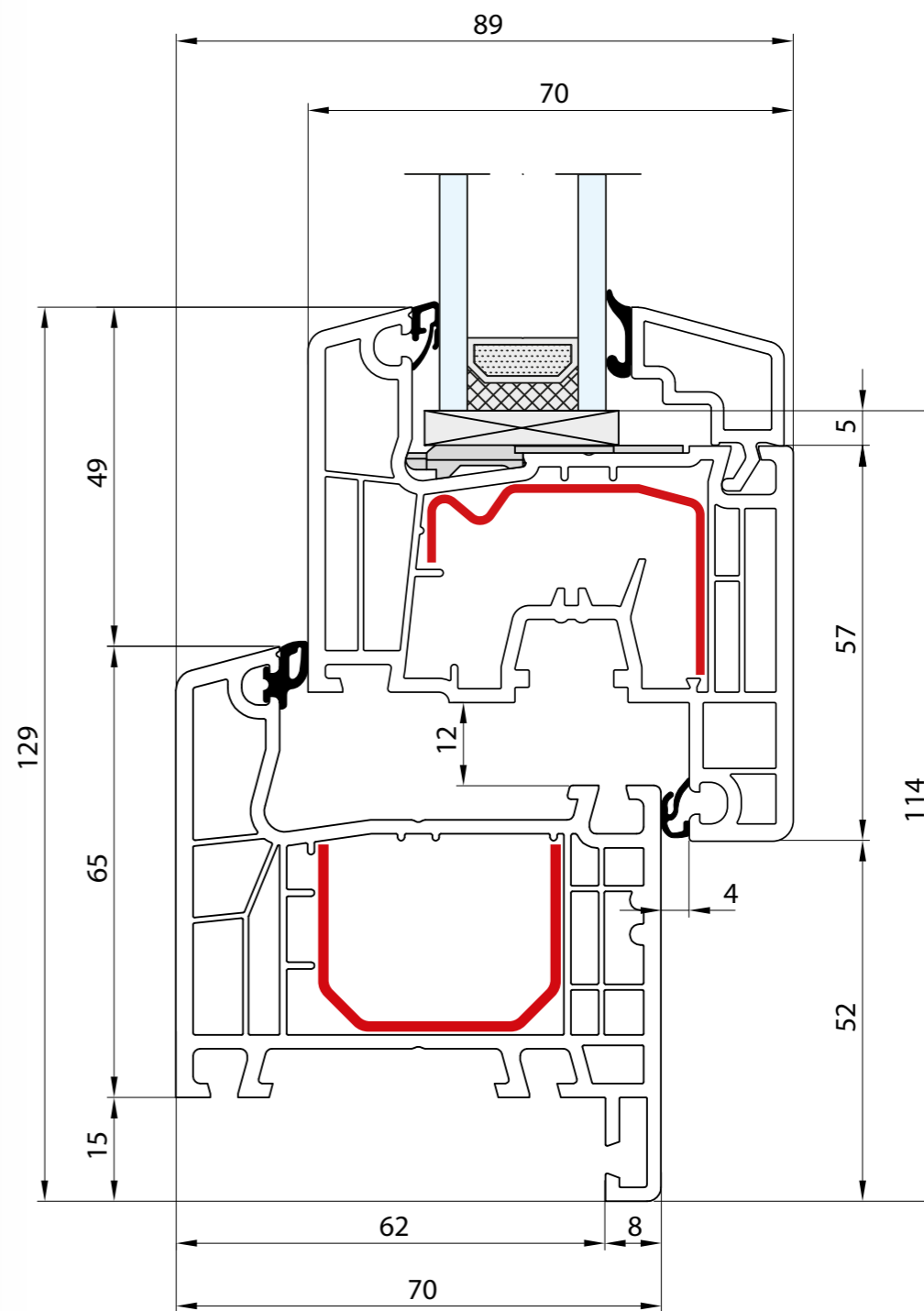
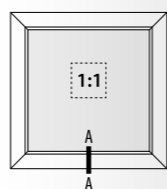

- MONOBLOCK - 70 mm · Rama: 80 mm · Skrzydło: 77 mm
- MONOBLOC - 70 mm · Dormant: 80 mm · Vantail: 77 mm
- MONOBLOK - 70 mm · Frame: 80 mm · Sash: 77 mm
- MONOBLOCK - 70 mm · Rahmen: 80 mm · Flügel: 77 mm
- MONOBLOCK - 70 mm · Telaio: 80 mm · Anta: 77 mm

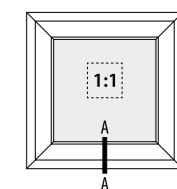

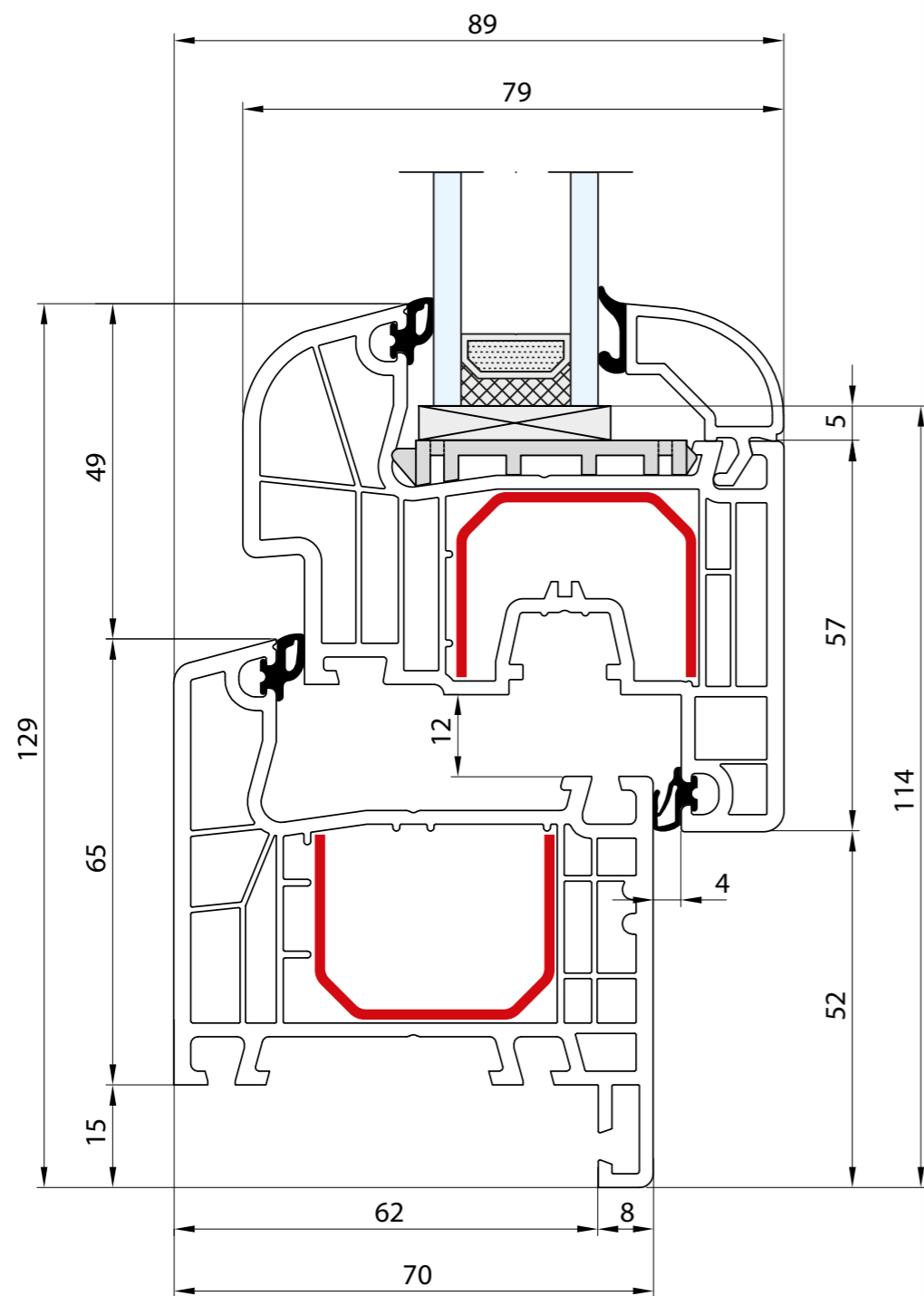

- MONOBLOCK - 70 mm · Rama: 80 mm · Skrzydło: 77 mm
- MONOBLOC - 70 mm · Dormant: 80 mm · Vantail: 77 mm
- MONOBLOK - 70 mm · Frame: 80 mm · Sash: 77 mm
- MONOBLOCK - 70 mm · Rahmen: 80 mm · Flügel: 77 mm
- MONOBLOCK - 70 mm · Telaio: 80 mm · Anta: 77 mm

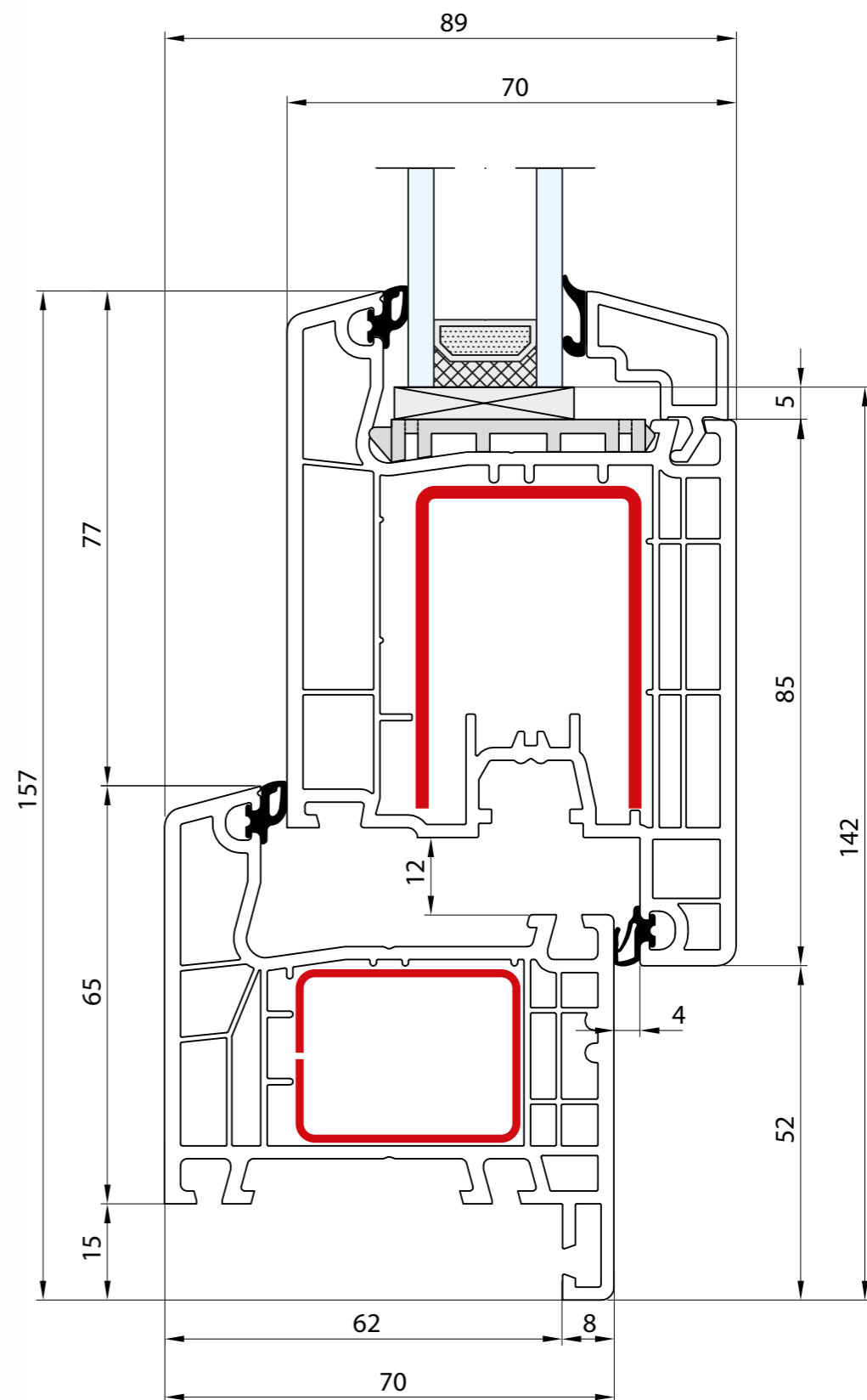
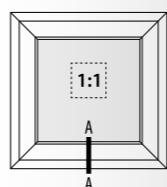

- MONOBLOCK - 70 mm · Rama: 80 mm · Skrzydło: 105 mm
- MONOBLOC - 70 mm · Dormant: 80 mm · Vantail: 105 mm
- MONOBLOK - 70 mm · Frame: 80 mm · Sash: 105 mm
- MONOBLOCK - 70 mm · Rahmen: 80 mm · Flügel: 105 mm
- MONOBLOCK - 70 mm · Telaio: 80 mm · Anta: 105 mm

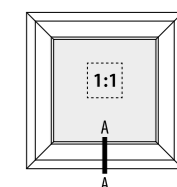

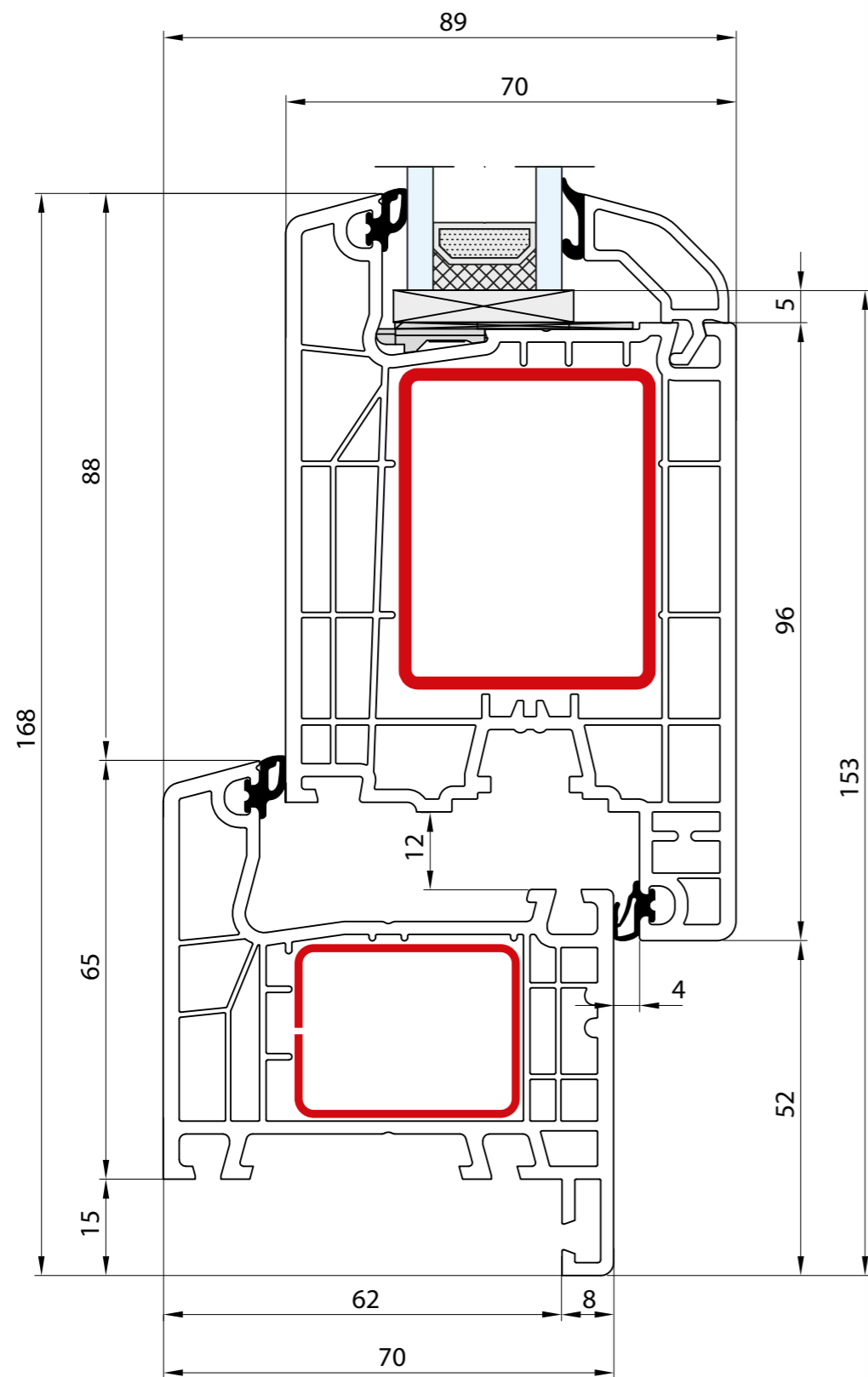

- MONOBLOCK - 70 mm · Rama: 80 mm · Skrzydło: 116 mm
- MONOBLOC - 70 mm · Dormant: 80 mm · Vantail: 116 mm
- MONOBLOK - 70 mm · Frame: 80 mm · Sash: 116 mm
- MONOBLOCK - 70 mm · Rahmen: 80 mm · Flügel: 116 mm
- MONOBLOCK - 70 mm · Telaio: 80 mm · Anta: 116 mm

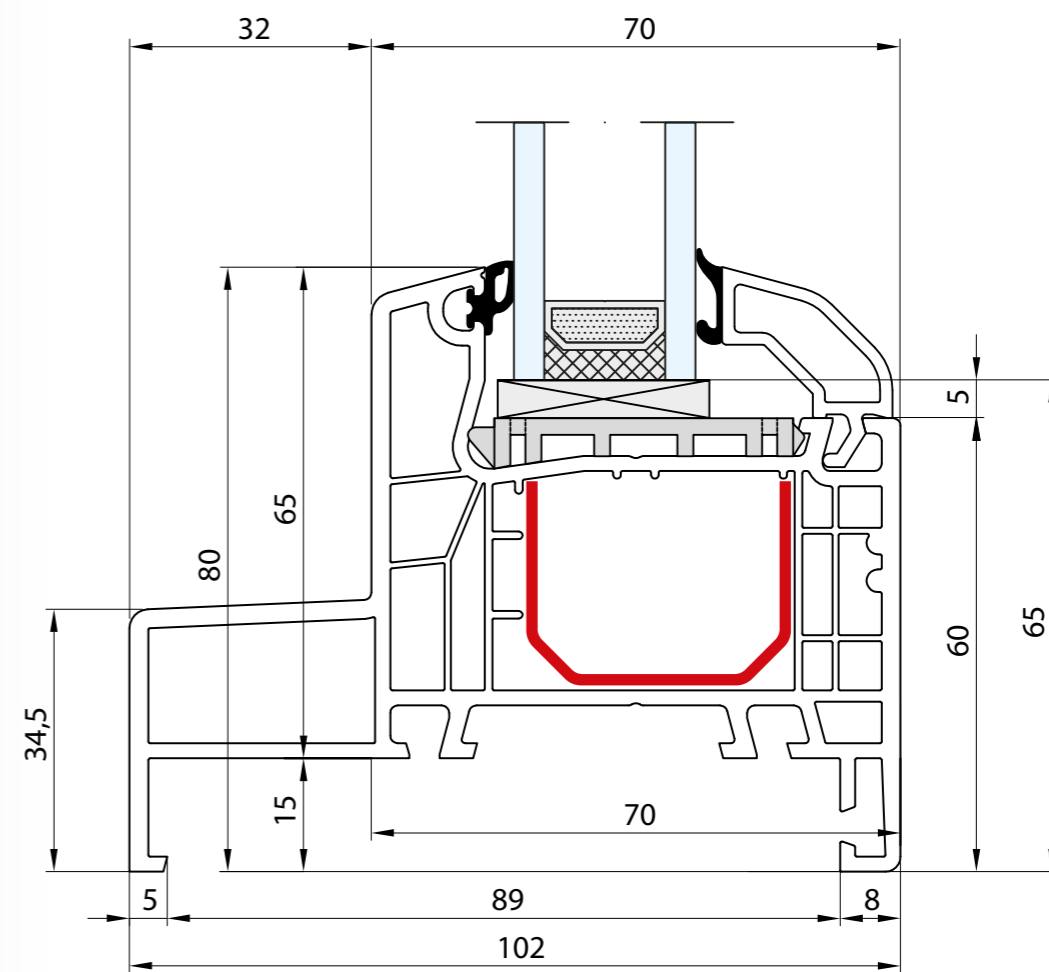
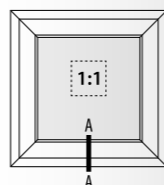

- MONOBLOCK - 100 mm · Rama: 80 mm
- MONOBLOC - 100 mm · Dormant: 80 mm
- MONOBLOK - 100 mm · Frame: 80 mm
- MONOBLOCK - 100 mm · Rahmen: 80 mm
- MONOBLOCK - 100 mm · Telaio: 80 mm

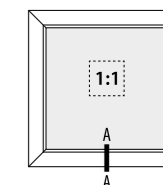

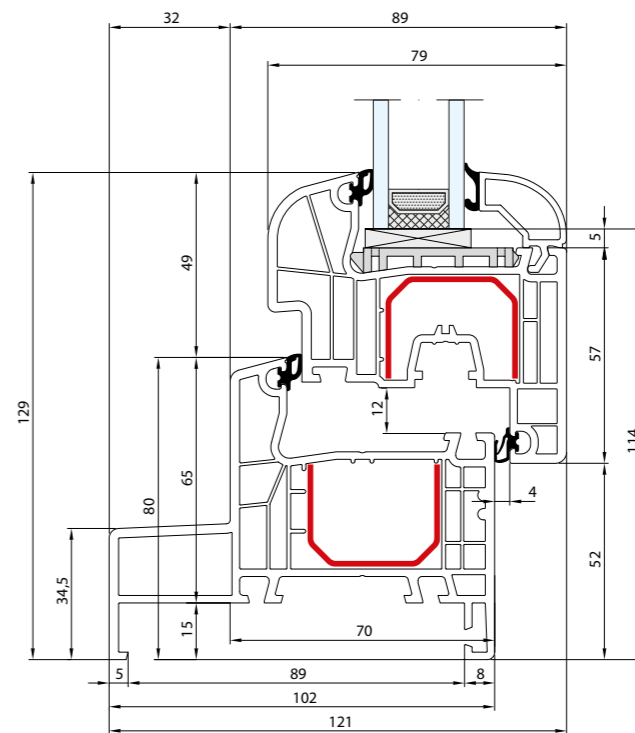
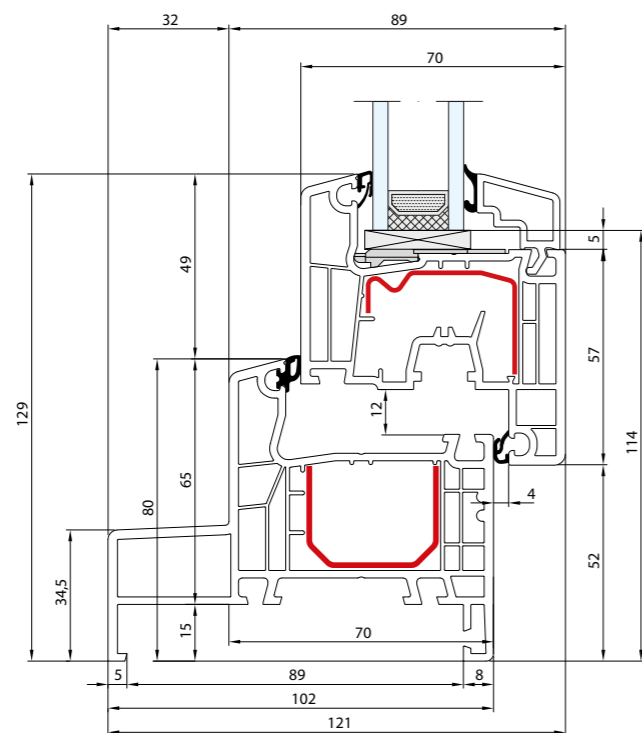

- MONOBLOCK - 100 mm · Rama: 80 mm · Skrzydło: 77 mm
- MONOBLOC - 100 mm · Dormant: 80 mm · Vantail: 77 mm
- MONOBLOK - 100 mm · Frame: 80 mm · Sash: 77 mm
- MONOBLOCK - 100 mm · Rahmen: 80 mm · Flügel: 77 mm
- MONOBLOCK - 100 mm · Telaio: 80 mm · Anta: 77 mm

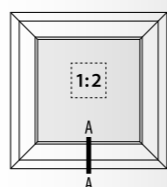

- MONOBLOCK - 100 mm · Rama: 80 mm · Skrzydło: 77 mm
- MONOBLOC - 100 mm · Dormant: 80 mm · Vantail: 77 mm
- MONOBLOK - 100 mm · Frame: 80 mm · Sash: 77 mm
- MONOBLOCK - 100 mm · Rahmen: 80 mm · Flügel: 77 mm
- MONOBLOCK - 100 mm · Telaio: 80 mm · Anta: 77 mm

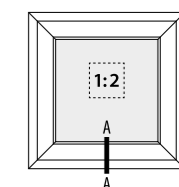

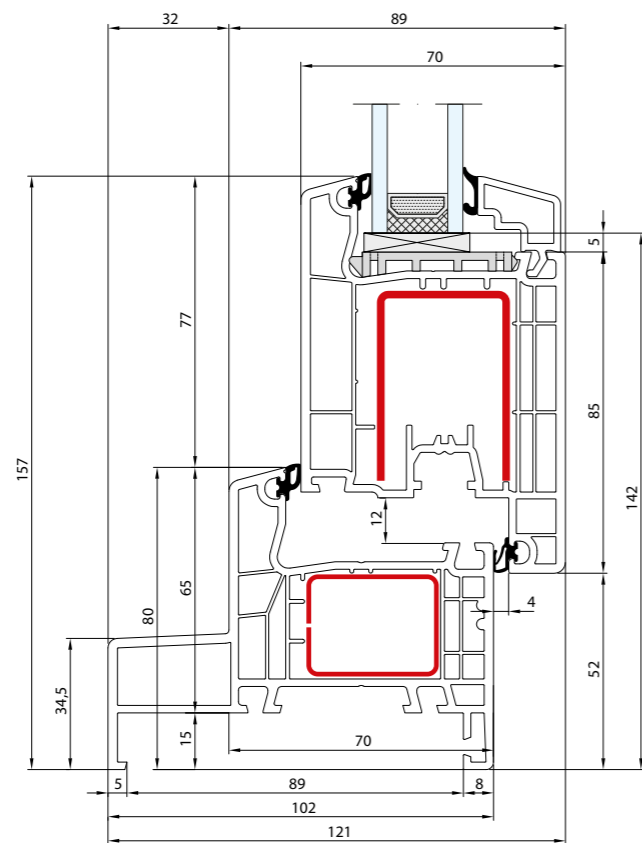

- MONOBLOCK - 100 mm · Rama: 80 mm · Skrzydło: 105 mm
- MONOBLOC - 100 mm · Dormant: 80 mm · Vantail: 105 mm
- MONOBLOK - 100 mm · Frame: 80 mm · Sash: 105 mm
- MONOBLOCK - 100 mm · Rahmen: 80 mm · Flügel: 105 mm
- MONOBLOCK - 100 mm · Telaio: 80 mm · Anta: 105 mm

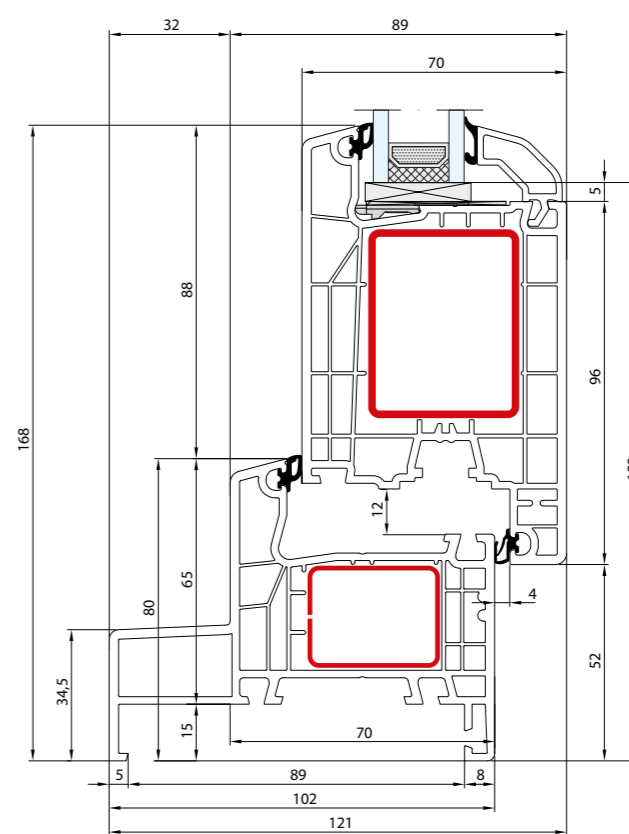
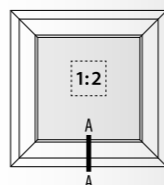

- MONOBLOCK - 100 mm · Rama: 80 mm · Skrzydło: 116 mm
- MONOBLOC - 100 mm · Dormant: 80 mm · Vantail: 116 mm
- MONOBLOK - 100 mm · Frame: 80 mm · Sash: 116 mm
- MONOBLOCK - 100 mm · Rahmen: 80 mm · Flügel: 116 mm
- MONOBLOCK - 100 mm · Telaio: 80 mm · Anta: 116 mm

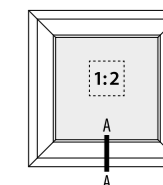

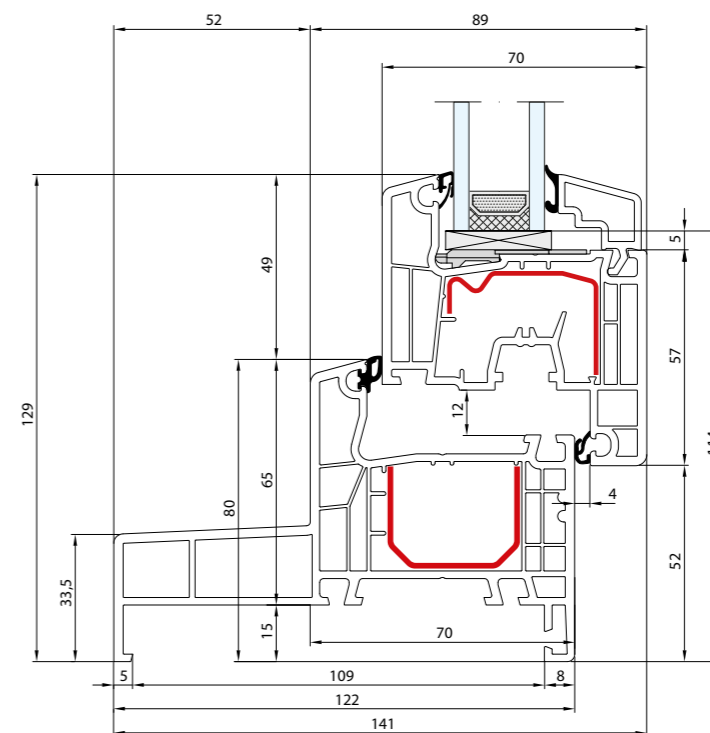
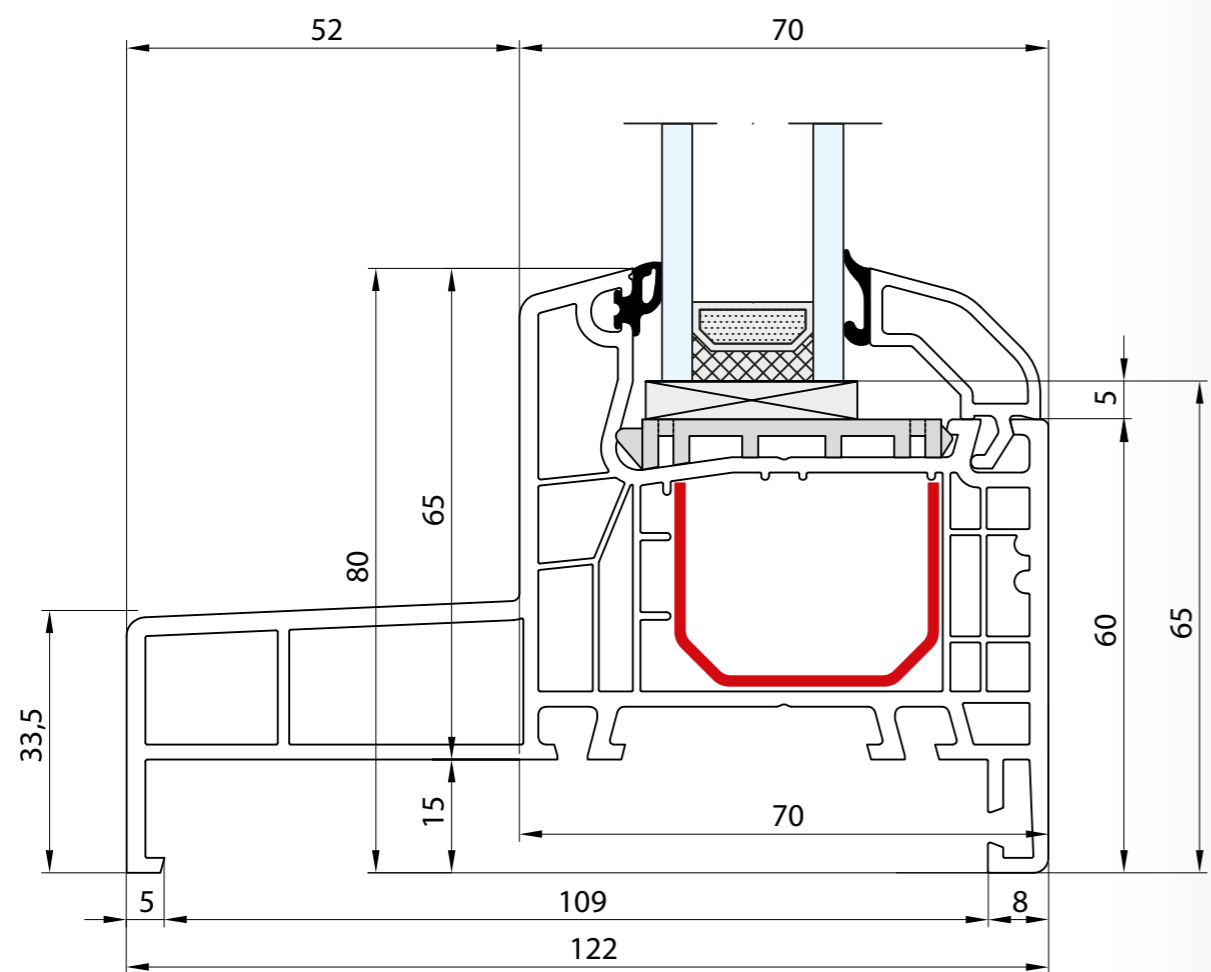

- MONOBLOCK - 120 mm · Rama: 80 mm
- MONOBLOC - 120 mm · Dormant: 80 mm
- MONOBLOK - 120 mm · Frame: 80 mm
- MONOBLOCK - 120 mm · Rahmen: 80 mm
- MONOBLOCK - 120 mm · Telaio: 80 mm

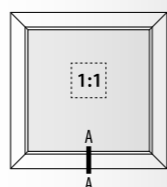

- MONOBLOCK - 120 mm · Rama: 80 mm · Skrzydło: 77 mm
- MONOBLOC - 120 mm · Dormant: 80 mm · Vantail: 77 mm
- MONOBLOK - 120 mm · Frame: 80 mm · Sash: 77 mm
- MONOBLOCK - 120 mm · Rahmen: 80 mm · Flügel: 77 mm
- MONOBLOCK - 120 mm · Telaio: 80 mm · Anta: 77 mm

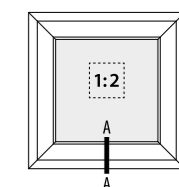

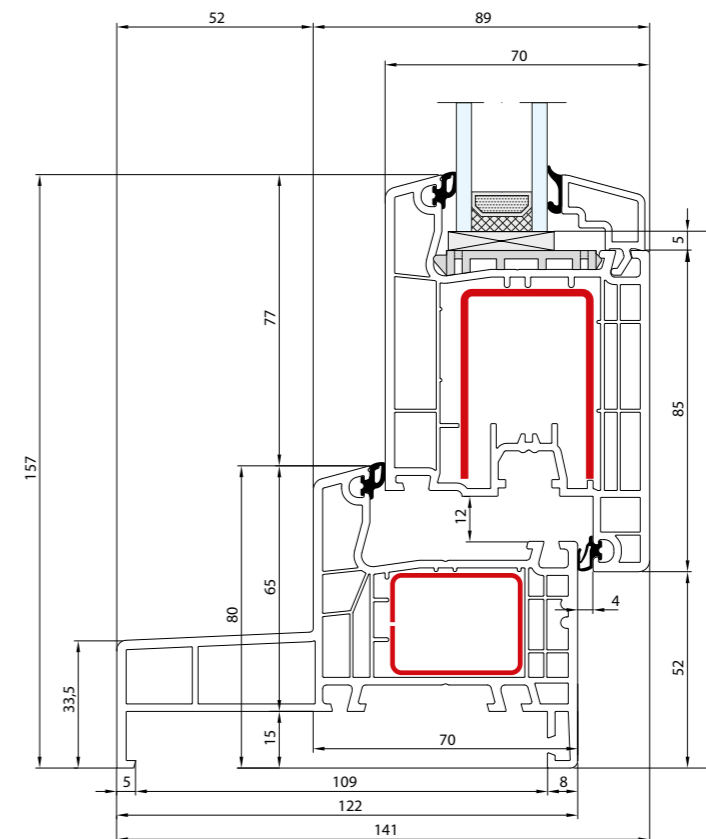
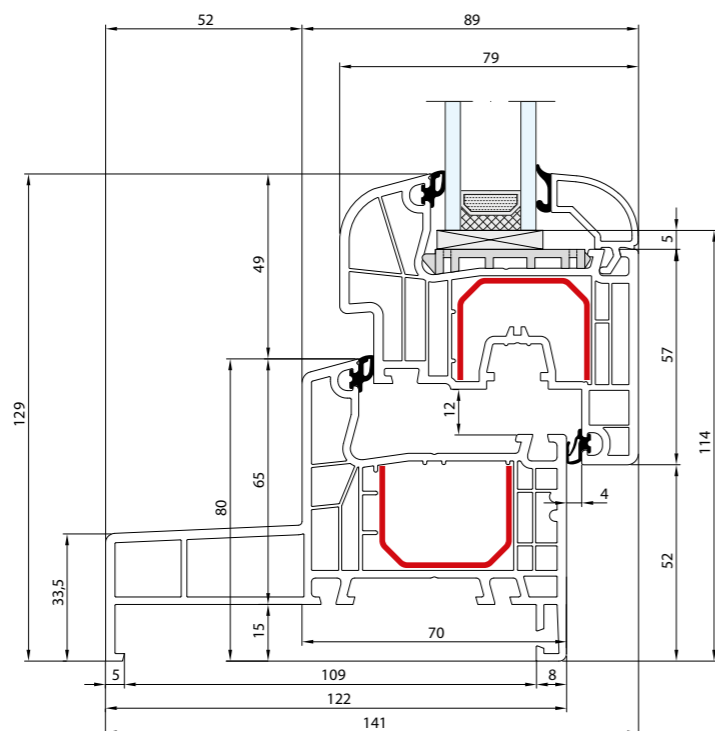

- MONOBLOCK - 120 mm · Rama: 80 mm · Skrzydło: 77 mm
- MONOBLOC - 120 mm · Dormant: 80 mm · Vantail: 77 mm
- MONOBLOK - 120 mm · Frame: 80 mm · Sash: 77 mm
- MONOBLOCK - 120 mm · Rahmen: 80 mm · Flügel: 77 mm
- MONOBLOCK - 120 mm · Telaio: 80 mm · Anta: 77 mm

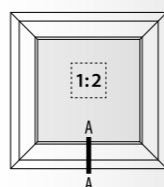

- MONOBLOCK - 120 mm · Rama: 80 mm · Skrzydło: 105 mm
- MONOBLOC - 120 mm · Dormant: 80 mm · Vantail: 105 mm
- MONOBLOK - 120 mm · Frame: 80 mm · Sash: 105 mm
- MONOBLOCK - 120 mm · Rahmen: 80 mm · Flügel: 105 mm
- MONOBLOCK - 120 mm · Telaio: 80 mm · Anta: 105 mm

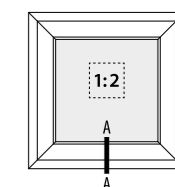

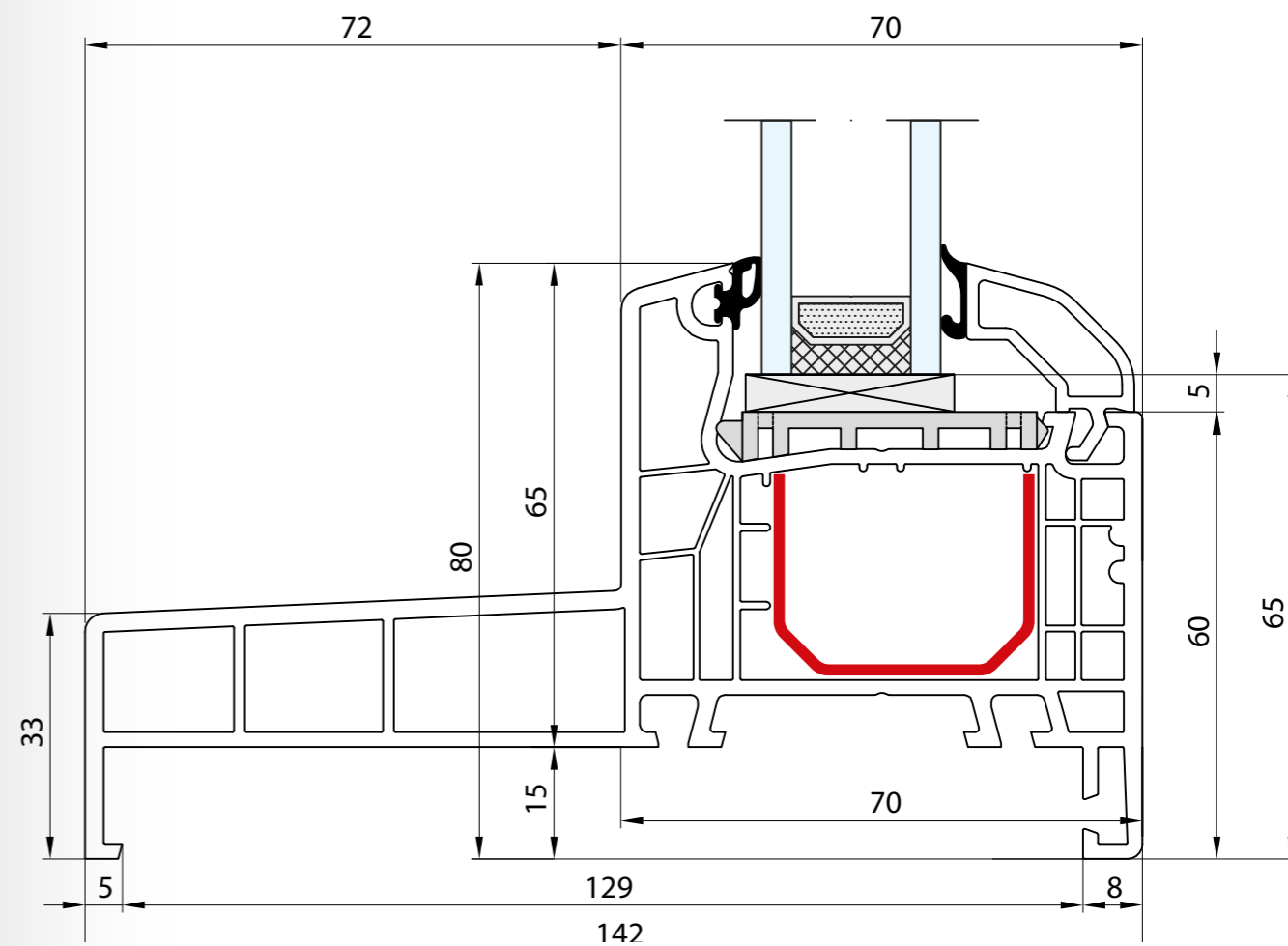
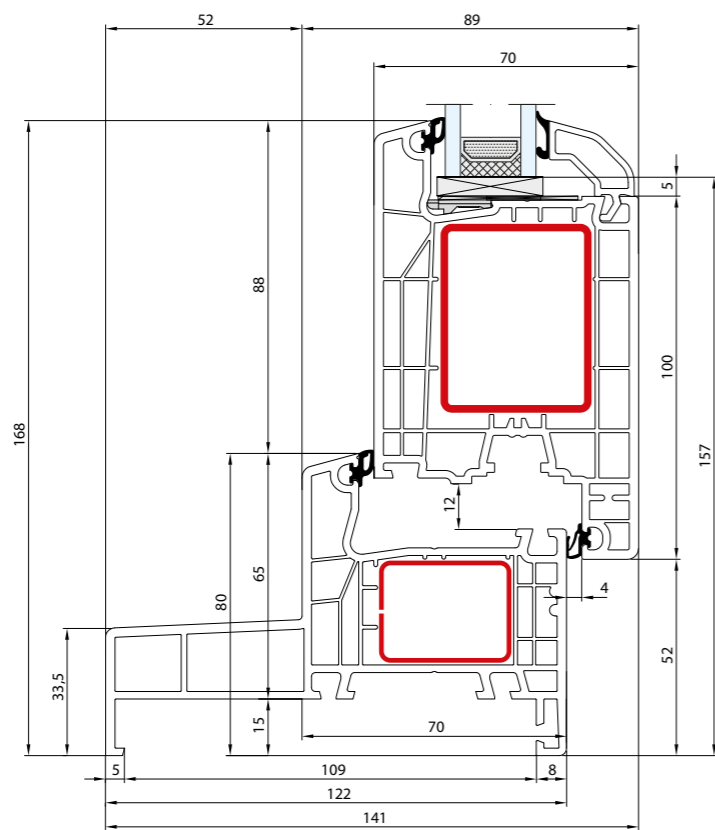

- MONOBLOCK - 120 mm · Rama: 80 mm · Skrzydło: 116 mm
- MONOBLOC - 120 mm · Dormant: 80 mm · Vantail: 116 mm
- MONOBLOK - 120 mm · Frame: 80 mm · Sash: 116 mm
- MONOBLOCK - 120 mm · Rahmen: 80 mm · Flügel: 116 mm
- MONOBLOCK - 120 mm · Telaio: 80 mm · Anta: 116 mm

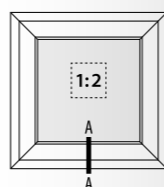

- MONOBLOCK - 140 mm · Rama: 80 mm
- MONOBLOC - 140 mm · Dormant: 80 mm
- MONOBLOK - 140 mm · Frame: 80 mm
- MONOBLOCK - 140 mm · Rahmen: 80 mm
- MONOBLOCK - 140 mm · Telaio: 80 mm

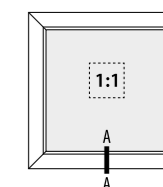

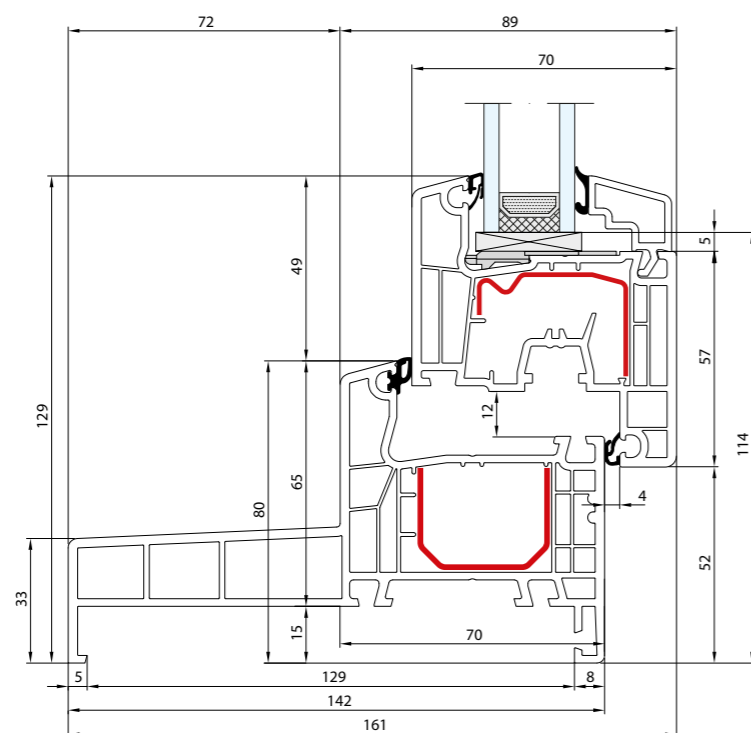

- MONOBLOCK - 140 mm · Rama: 80 mm · Skrzydło: 77 mm
- MONOBLOC - 140 mm · Dormant: 80 mm · Vantail: 77 mm
- MONOBLOK - 140 mm · Frame: 80 mm · Sash: 77 mm
- MONOBLOCK - 140 mm · Rahmen: 80 mm · Flügel: 77 mm
- MONOBLOCK - 140 mm · Telaio: 80 mm · Anta: 77 mm

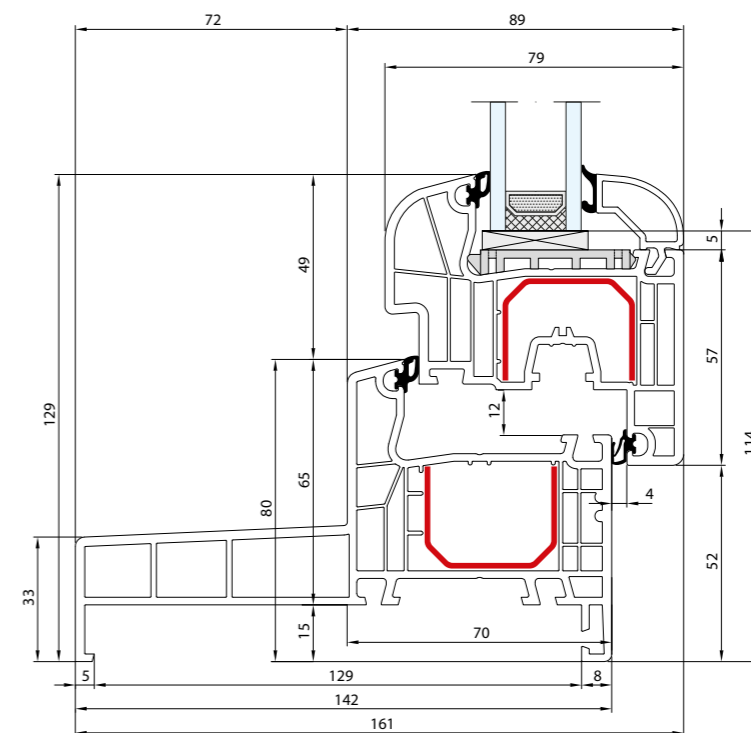
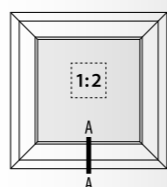

- MONOBLOCK - 140 mm · Rama: 80 mm · Skrzydło: 77 mm
- MONOBLOC - 140 mm · Dormant: 80 mm · Vantail: 77 mm
- MONOBLOK - 140 mm · Frame: 80 mm · Sash: 77 mm
- MONOBLOCK - 140 mm · Rahmen: 80 mm · Flügel: 77 mm
- MONOBLOCK - 140 mm · Telaio: 80 mm · Anta: 77 mm

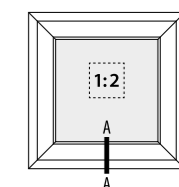

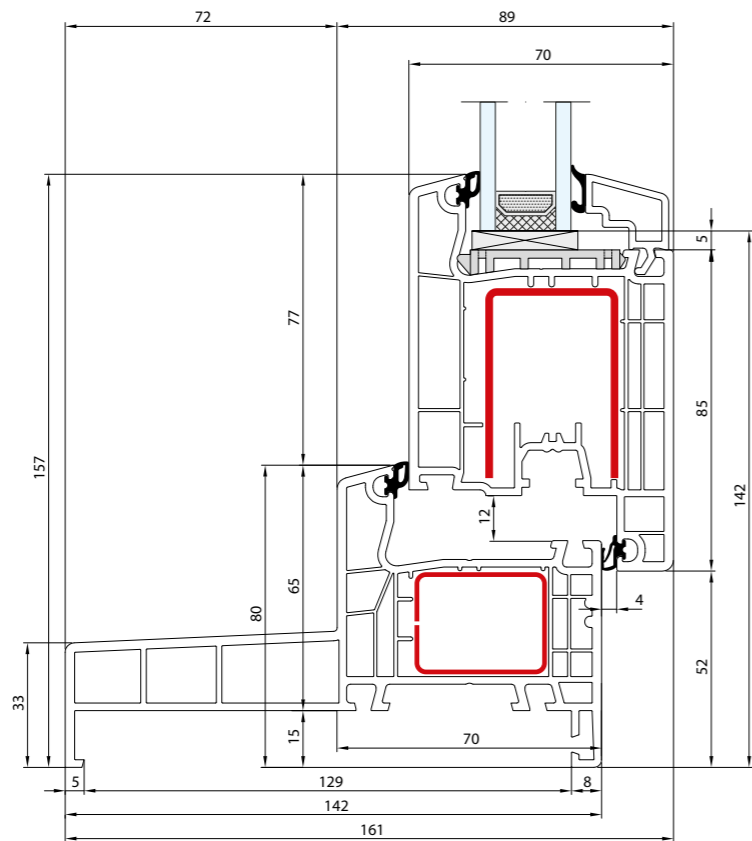

- MONOBLOCK - 140 mm · Rama: 80 mm · Skrzydło: 105 mm
- MONOBLOC -140 mm · Dormant: 80 mm · Vantail: 105 mm
- MONOBLOK - 140 mm · Frame: 80 mm · Sash: 105 mm
- MONOBLOCK - 140 mm · Rahmen: 80 mm · Flügel: 105 mm
- MONOBLOCK - 140 mm · Telaio: 80 mm · Anta: 105 mm

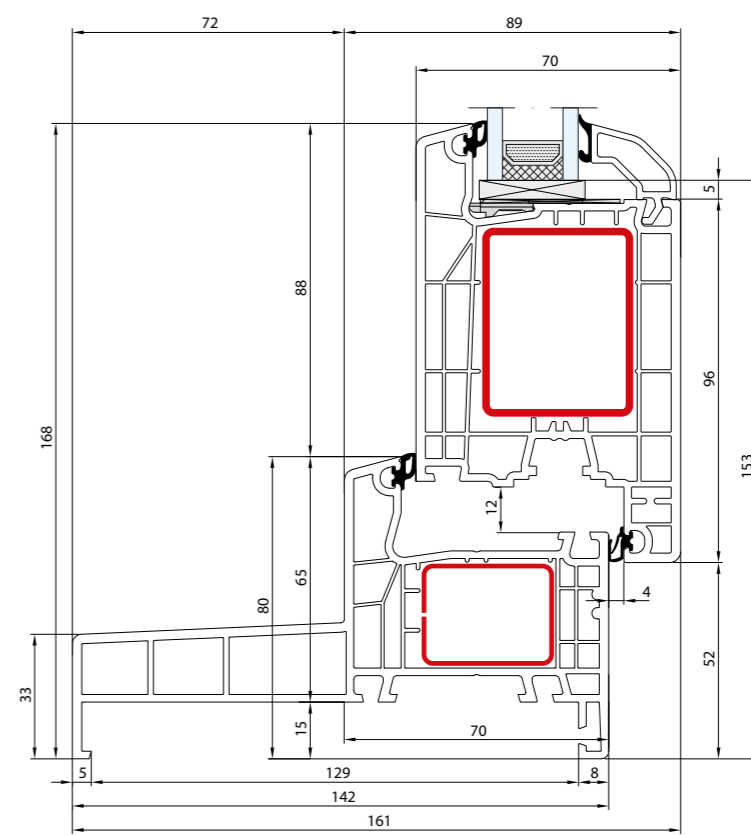
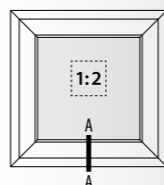

- MONOBLOCK - 140 mm · Rama: 80 mm · Skrzydło: 116 mm
- MONOBLOC -140 mm · Dormant: 80 mm · Vantail: 116 mm
- MONOBLOK - 140 mm · Frame: 80 mm · Sash: 116 mm
- MONOBLOCK - 140 mm · Rahmen: 80 mm · Flügel: 116 mm
- MONOBLOCK - 140 mm · Telaio: 80 mm · Anta: 116 mm

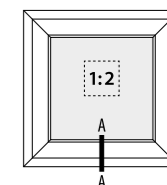

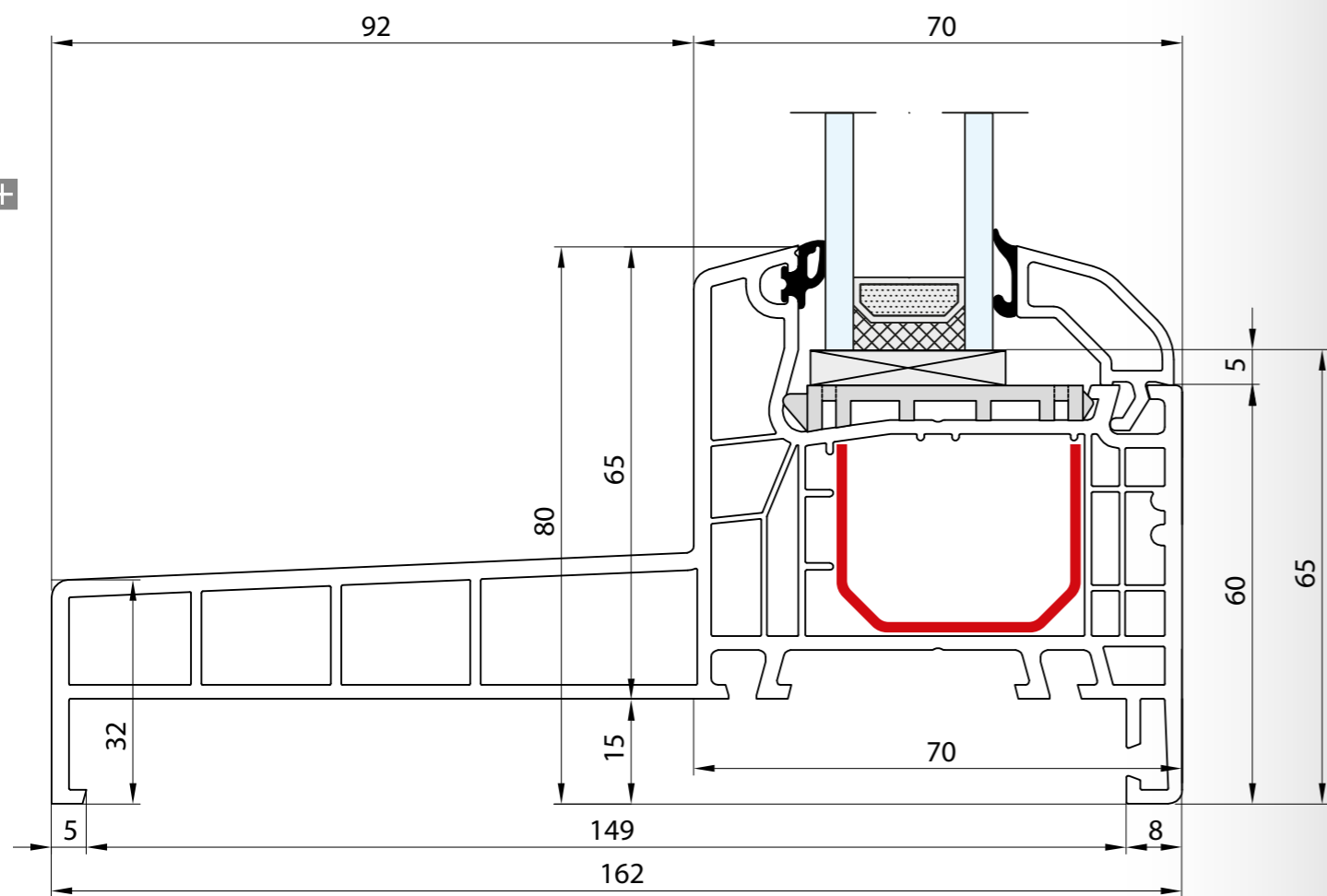

- MONOBLOCK - 160 mm · Rama: 80 mm
- MONOBLOC - 160 mm · Dormant: 80 mm
- MONOBLOK - 160 mm · Frame: 80 mm
- MONOBLOCK - 160 mm · Rahmen: 80 mm
- MONOBLOCK - 160 mm · Telaio: 80 mm

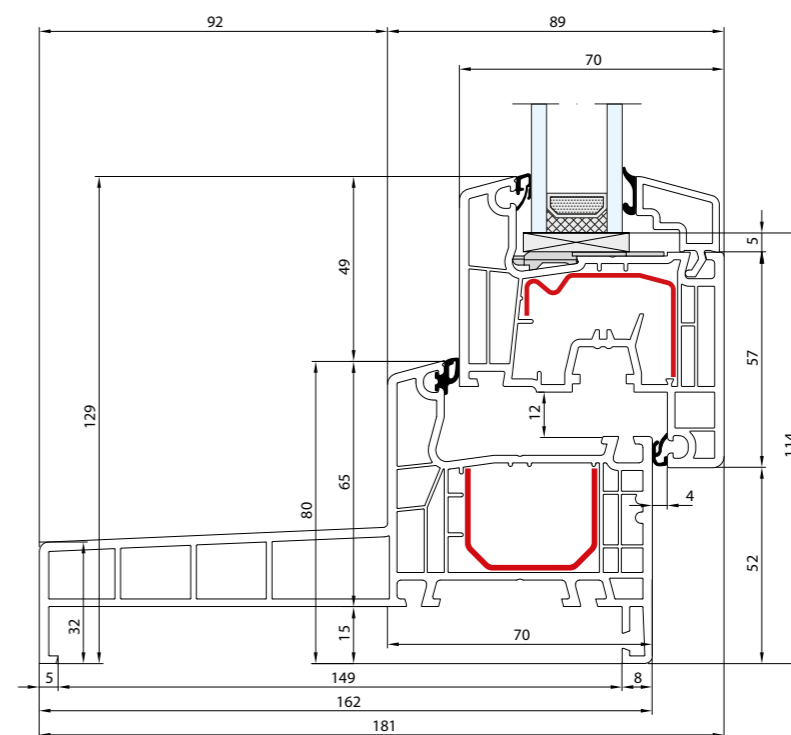
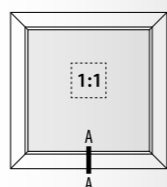

- MONOBLOCK - 160 mm · Rama: 80 mm · Skrzydło: 77 mm
- MONOBLOC - 160 mm · Dormant: 80 mm · Vantail: 77 mm
- MONOBLOK - 160 mm · Frame: 80 mm · Sash: 77 mm
- MONOBLOCK - 160 mm · Rahmen: 80 mm · Flügel: 77 mm
- MONOBLOCK - 160 mm · Telaio: 80 mm · Anta: 77 mm

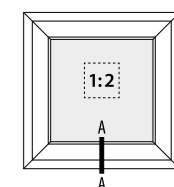

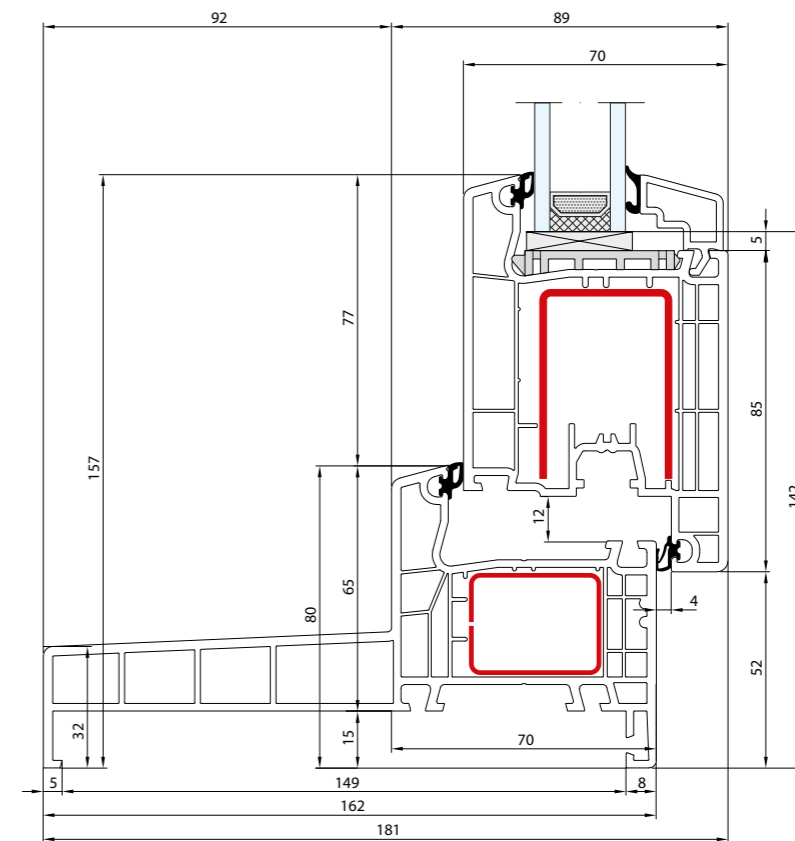
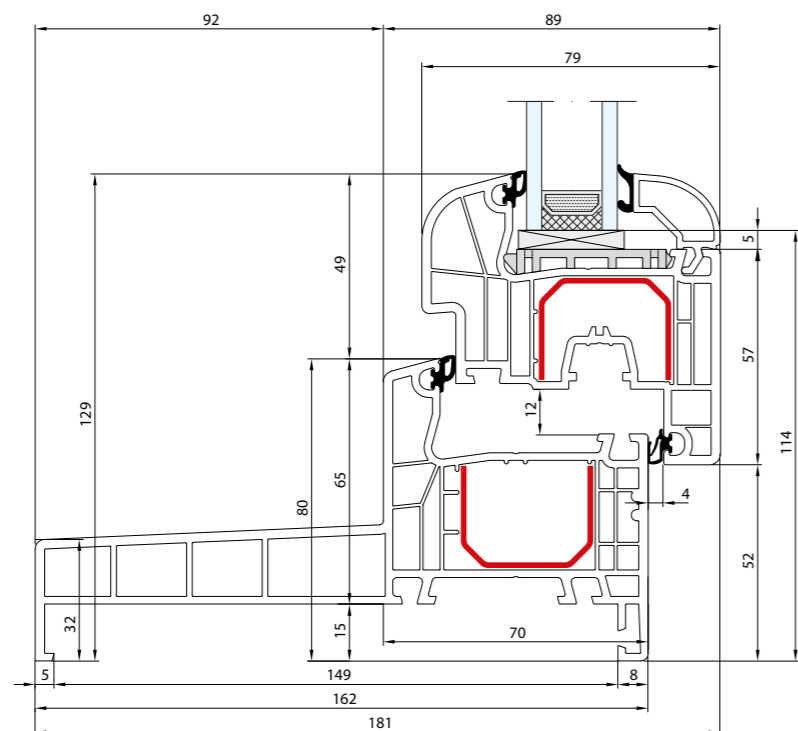

- MONOBLOCK - 160 mm · Rama: 80 mm · Skrzydło: 77 mm
- MONOBLOC - 160 mm · Dormant: 80 mm · Vantail: 77 mm
- MONOBLOK - 160 mm · Frame: 80 mm · Sash: 77 mm
- MONOBLOCK - 160 mm · Rahmen: 80 mm · Flügel: 77 mm
- MONOBLOCK - 160 mm · Telaio: 80 mm · Anta: 77 mm

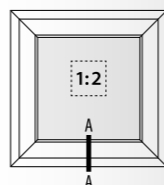

- MONOBLOCK - 160 mm · Rama: 80 mm · Skrzydło: 105 mm
- MONOBLOC - 160 mm · Dormant: 80 mm · Vantail: 105 mm
- MONOBLOK - 160 mm · Frame: 80 mm · Sash: 105 mm
- MONOBLOCK - 160 mm · Rahmen: 80 mm · Flügel: 105 mm
- MONOBLOCK - 160 mm · Telaio: 80 mm · Anta: 105 mm

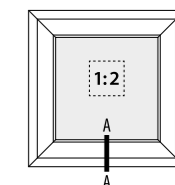

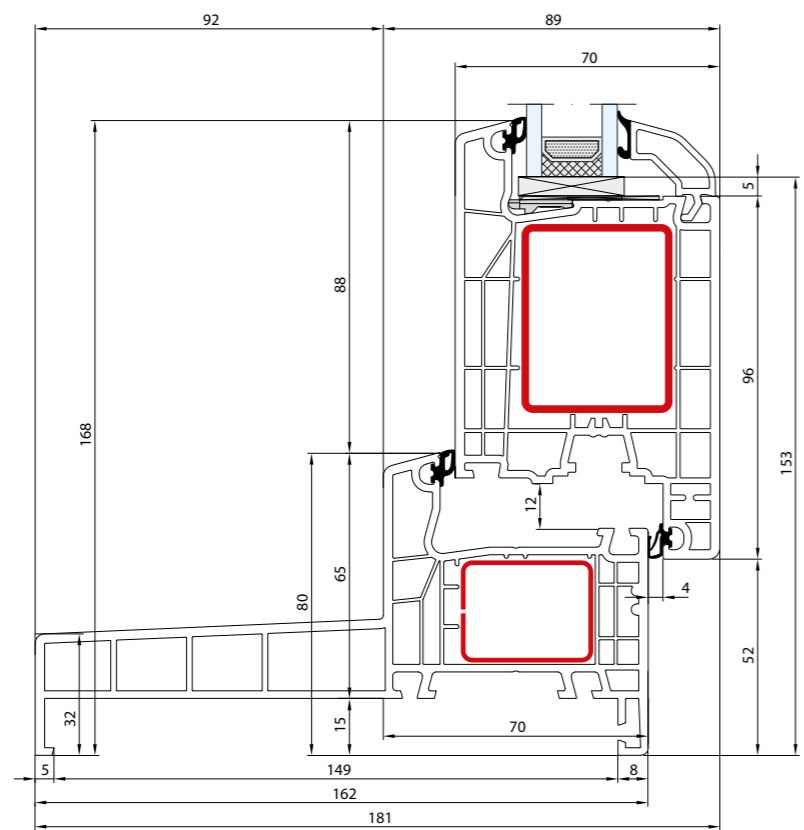

- MONOBLOCK - 160 mm · Rama: 80 mm · Skrzydło: 116 mm
- MONOBLOC - 160 mm · Dormant: 80 mm · Vantail: 116 mm
- MONOBLOK - 160 mm · Frame: 80 mm · Sash: 116 mm
- MONOBLOCK - 160 mm · Rahmen: 80 mm · Flügel: 116 mm
- MONOBLOCK - 160 mm · Telaio: 80 mm · Anta: 116 mm

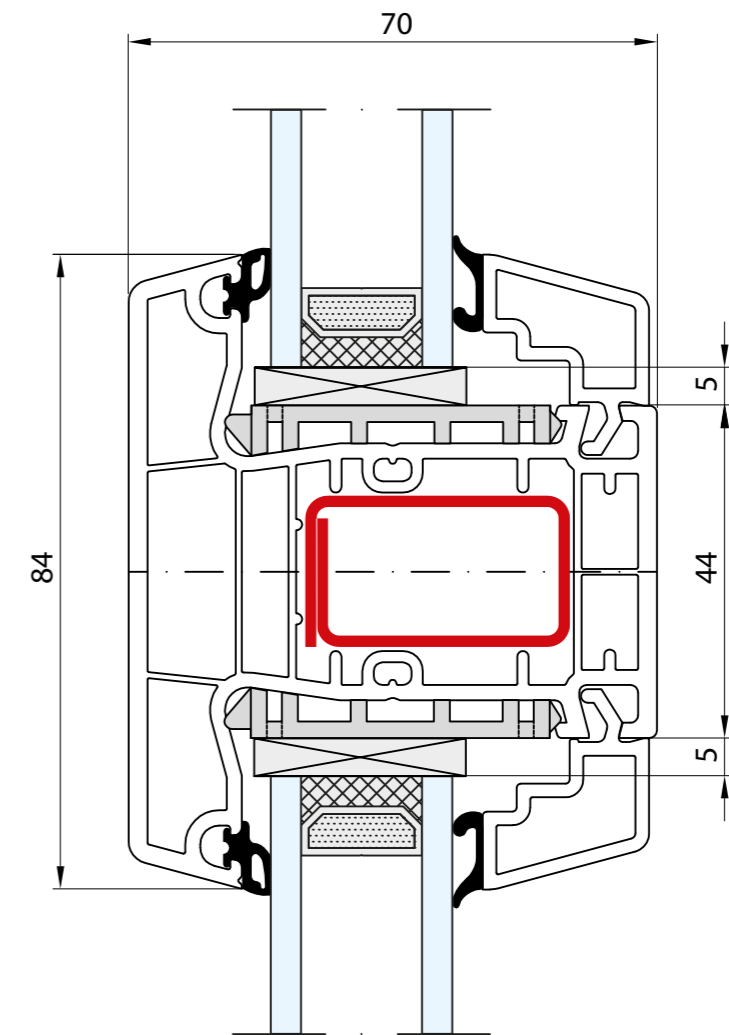
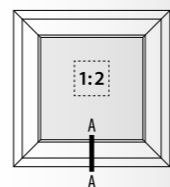

- Słupek stały: 84 mm
- Meneau fixe: 84 mm
- Fix post: 84 mm
- Festem Pfahl: 84 mm
- Montante fisso: 84 mm

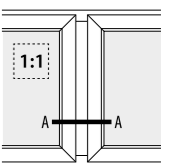

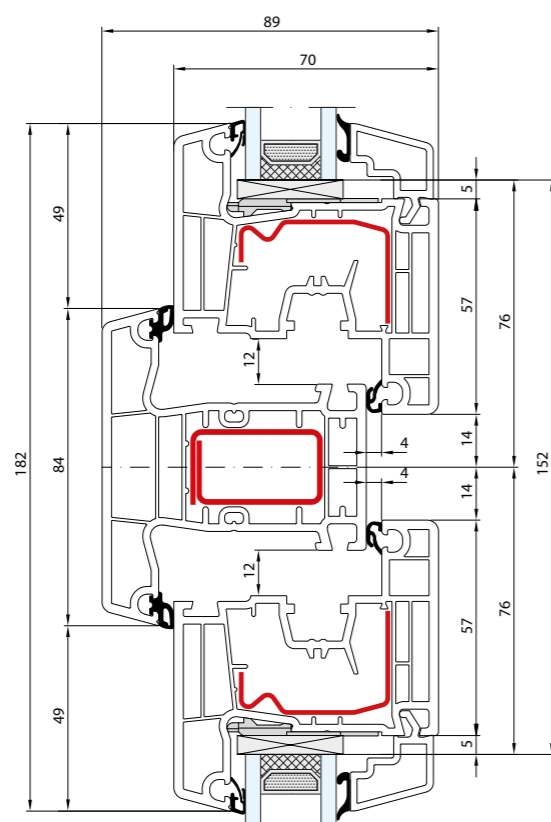

- Słupek stały: 84 mm · Skrzydło: 77 mm
- Meneau fixe: 84 mm · Vantail: 77 mm
- Fix post: 84 mm · Sash: 77 mm
- Festem Pfahl: 84 mm · Flügel: 77 mm
- Montante fisso: 84 mm · Anta: 77 mm

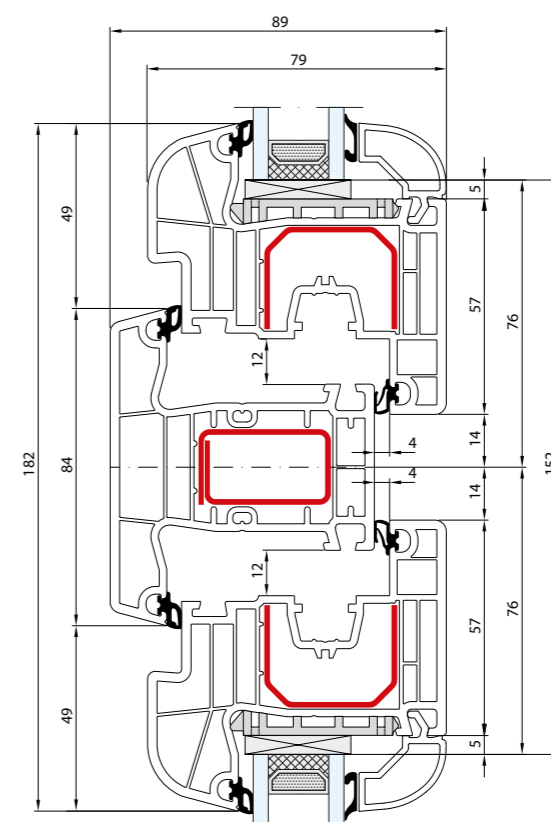
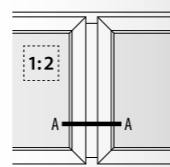

- Słupek stały: 84 mm · Skrzydło: 77 mm
- Meneau fixe: 84 mm · Vantail: 77 mm
- Fix post: 84 mm · Sash: 77 mm
- Festem Pfahl: 84 mm · Flügel: 77 mm
- Montante fisso: 84 mm · Anta: 77 mm

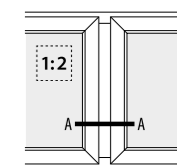

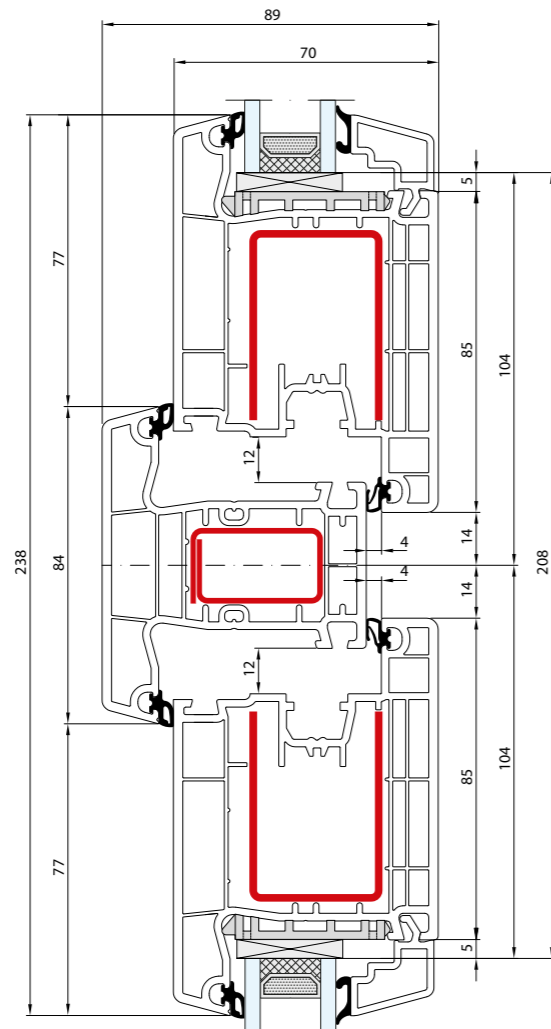



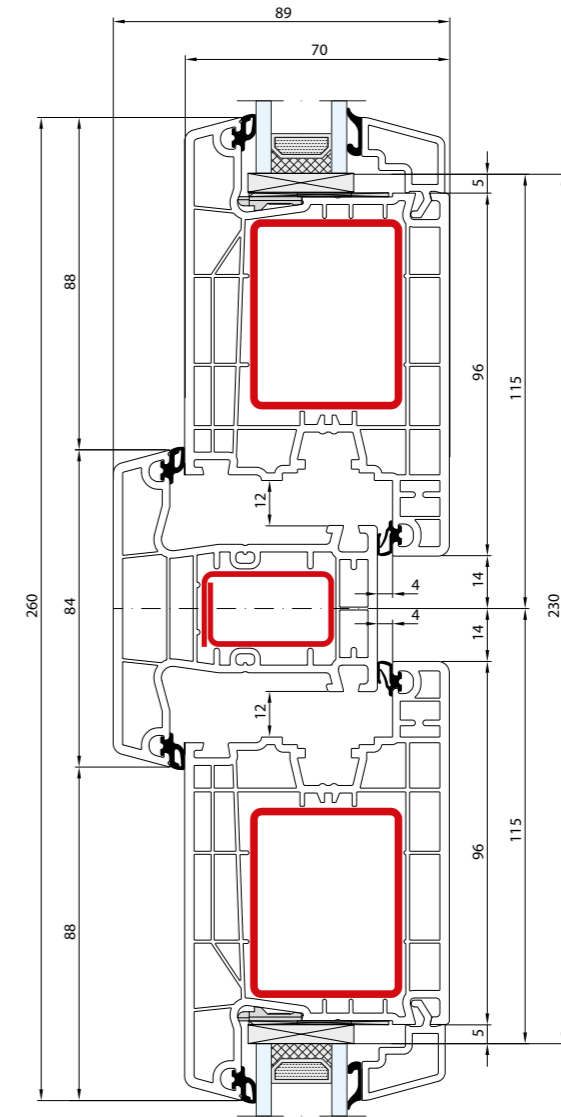
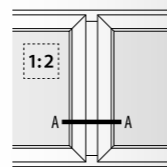

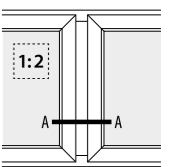

- Słupek stały: 84 mm · Skrzydło: 105 mm
- Meneau fixe: 84 mm · Vantail: 105 mm
- Fix post: 84 mm · Sash: 105 mm
- Festem Pfahl: 84 mm · Flügel: 105 mm
- Montante fisso: 84 mm · Anta: 105 mm

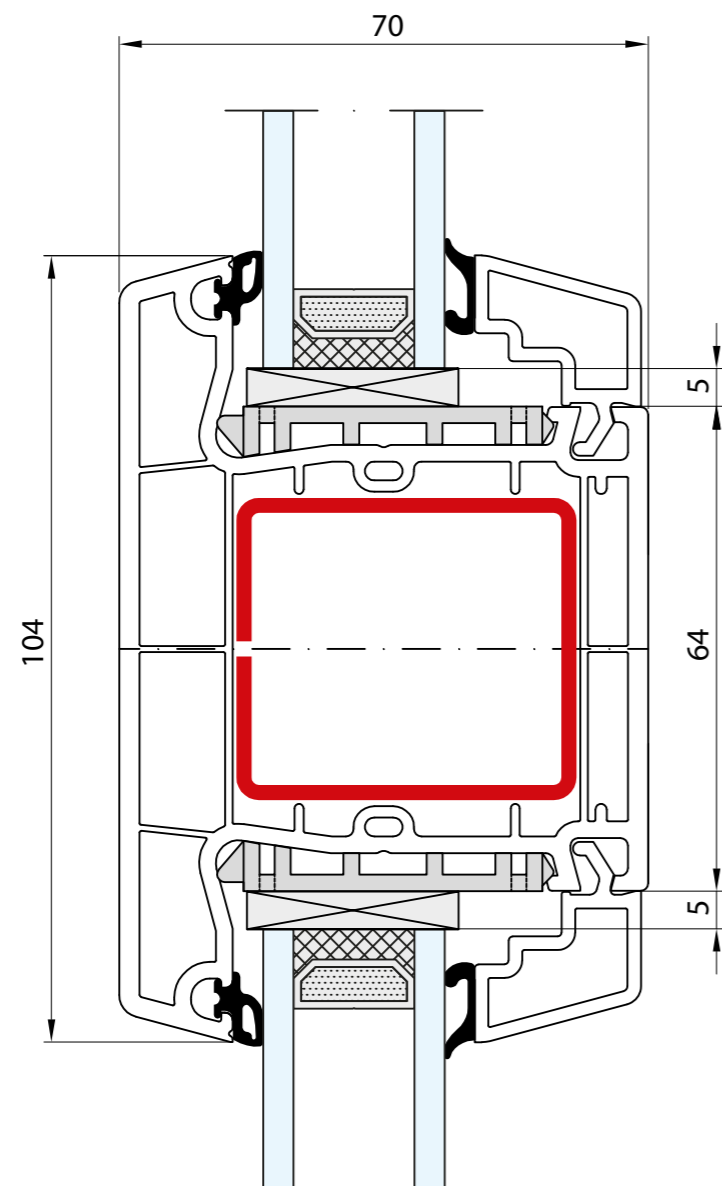







- Słupek stały: 84 mm · Skrzydło: 116 mm
- Meneau fixe: 84 mm · Vantail: 116 mm
- Fix post: 84 mm · Sash: 116 mm
- Festem Pfahl: 84 mm · Flügel: 116 mm
- Montante fisso: 84 mm · Anta: 116 mm

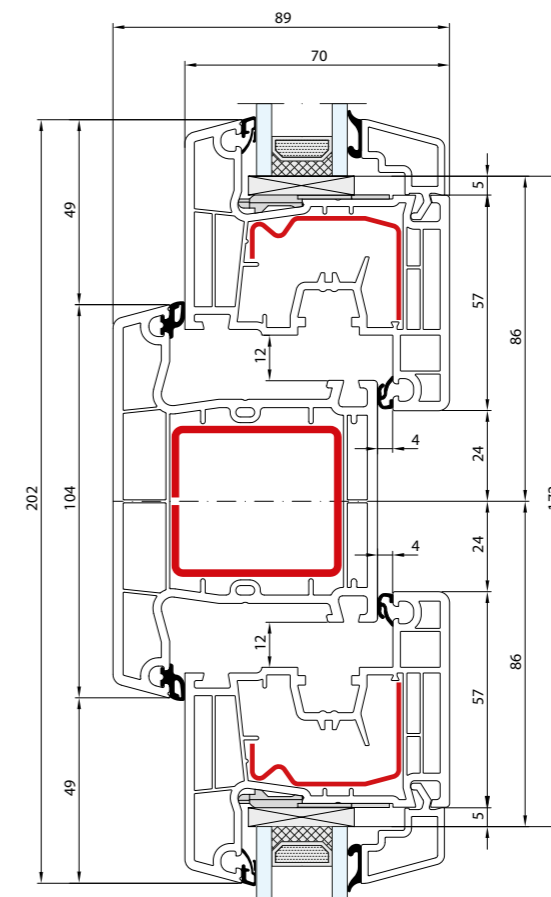
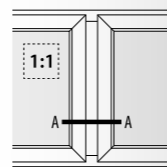



-  Słupek stały: 104 mm
-  Meneau fixe: 104 mm
-  Fix post: 104 mm
-  Festem Pfahl: 104 mm
-  Montante fisso: 104 mm



-  Słupek stały: 104 mm · Skrzydło: 77 mm
-  Meneau fixe: 104 mm · Vantail: 77 mm
-  Fix post: 104 mm · Sash: 77 mm
-  Festem Pfahl: 104 mm · Flügel: 77 mm
-  Montante fisso: 104 mm · Anta: 77 mm

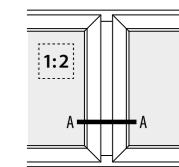

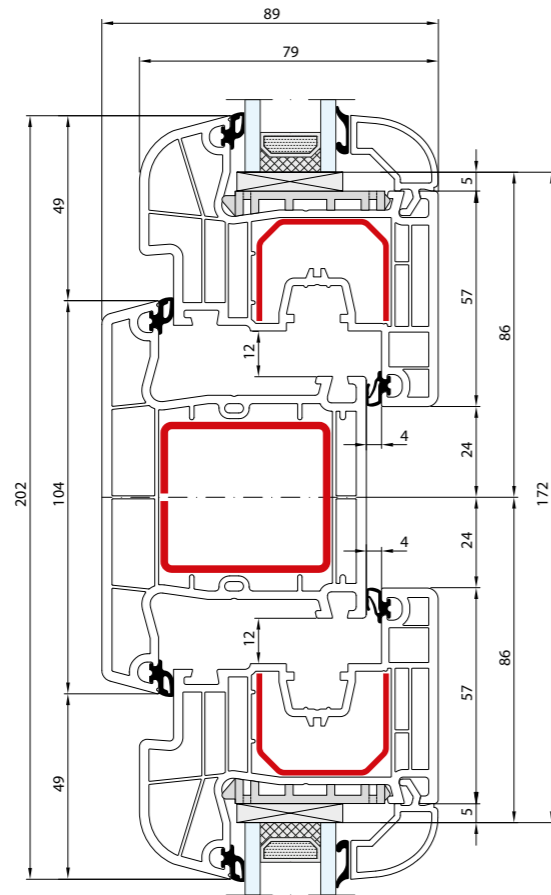

-  Słupek stały: 104 mm · Skrzydło: 77 mm
-  Meneau fixe: 104 mm · Vantail: 77 mm
-  Fix post: 104 mm · Sash: 77 mm
-  Festem Pfahl: 104 mm · Flügel: 77 mm
-  Montante fisso: 104 mm · Anta: 77 mm

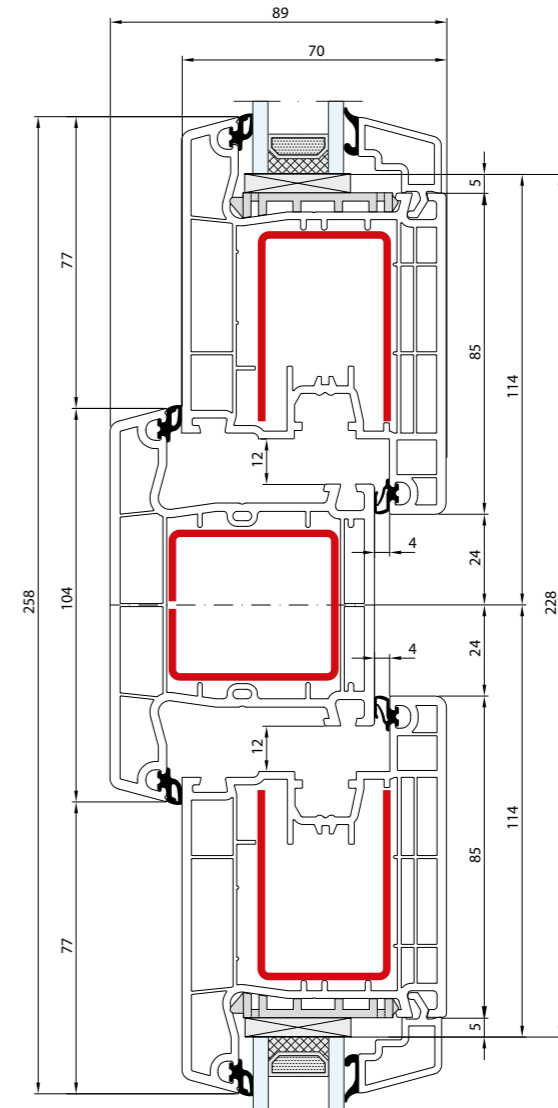
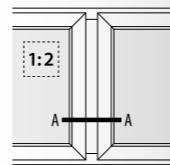

-  Słupek stały: 104 mm · Skrzydło: 105 mm
-  Meneau fixe: 104 mm · Vantail: 105 mm
-  Fix post: 104 mm · Sash: 105 mm
-  Festem Pfahl: 104 mm · Flügel: 105 mm
-  Montante fisso: 104 mm · Anta: 105 mm

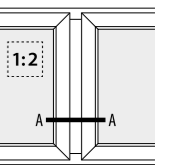

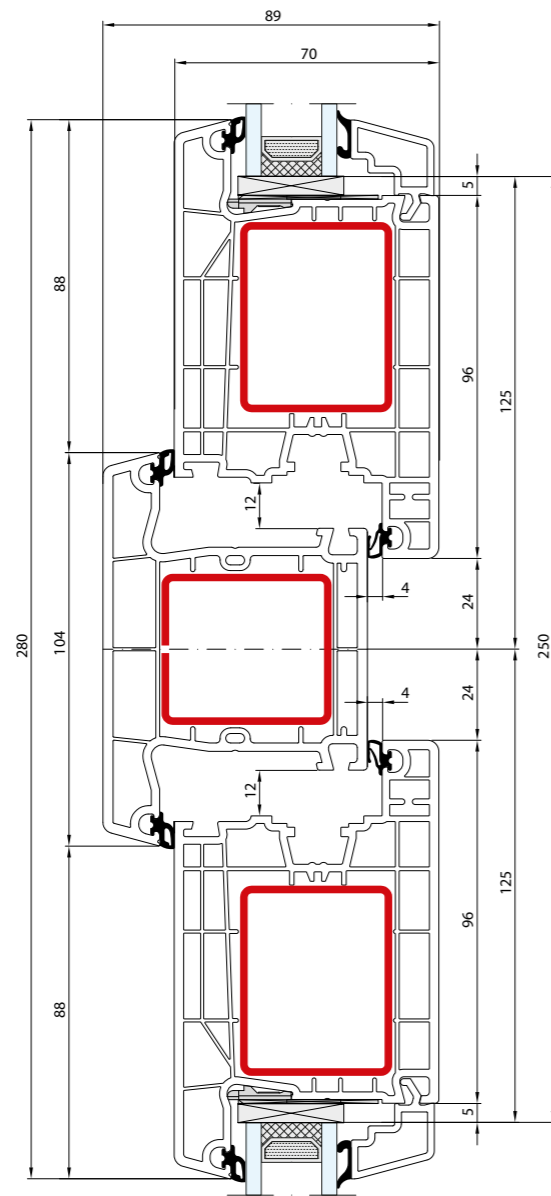

- Słupek stały: 104 mm · Skrzydło: 116 mm
- Meneau fixe: 104 mm · Vantail: 116 mm
- Fix post: 104 mm · Sash: 116 mm
- Festem Pfahl: 104 mm · Flügel: 116 mm
- Montante fisso: 104 mm · Anta: 116 mm

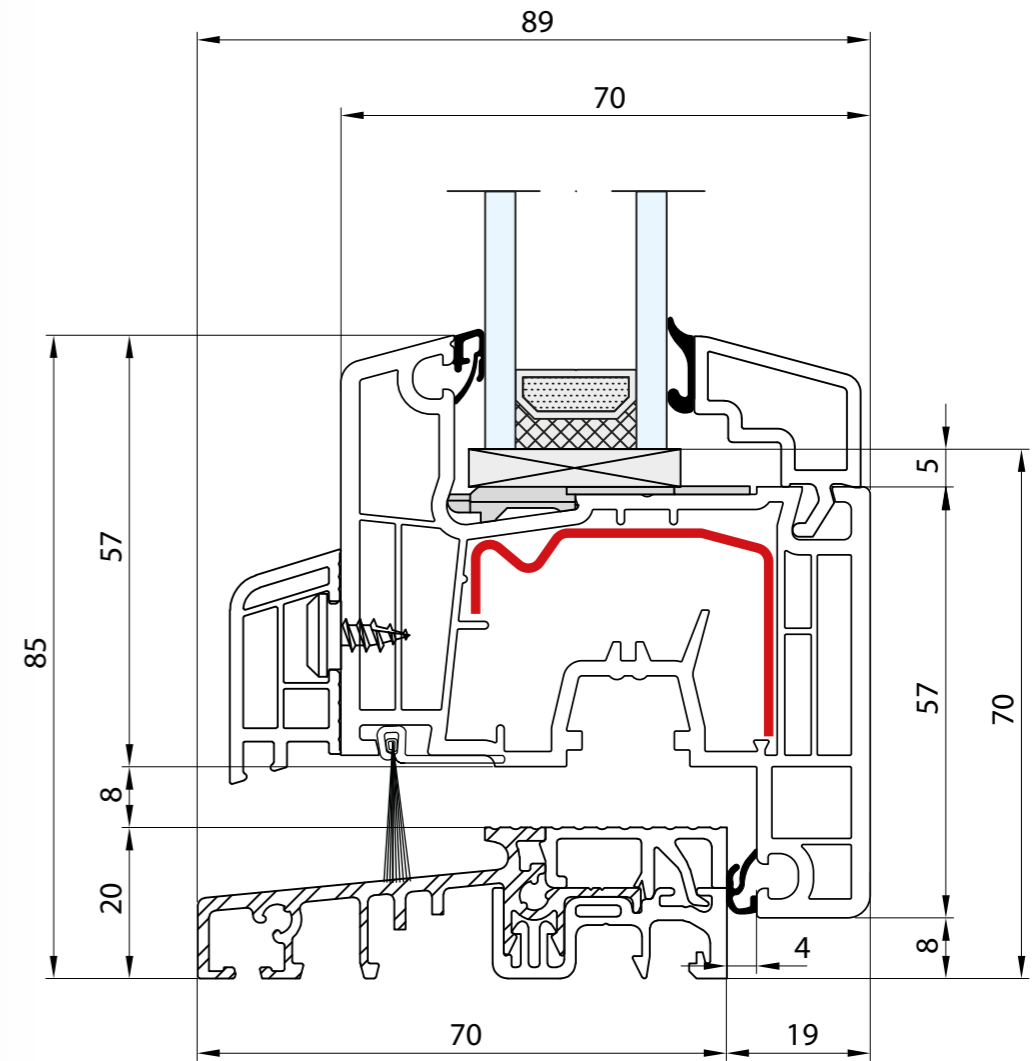
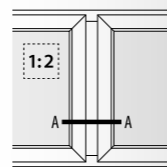

- Próg: 20 mm · Skrzydło: 77 mm
- Seuil: 20 mm · Vantail: 77 mm
- Threshold: 20 mm · Sash: 77 mm
- Schwelle: 20 mm · Flügel: 77 mm
- Soglia: 20 mm · Anta: 77 mm

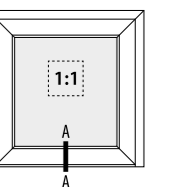

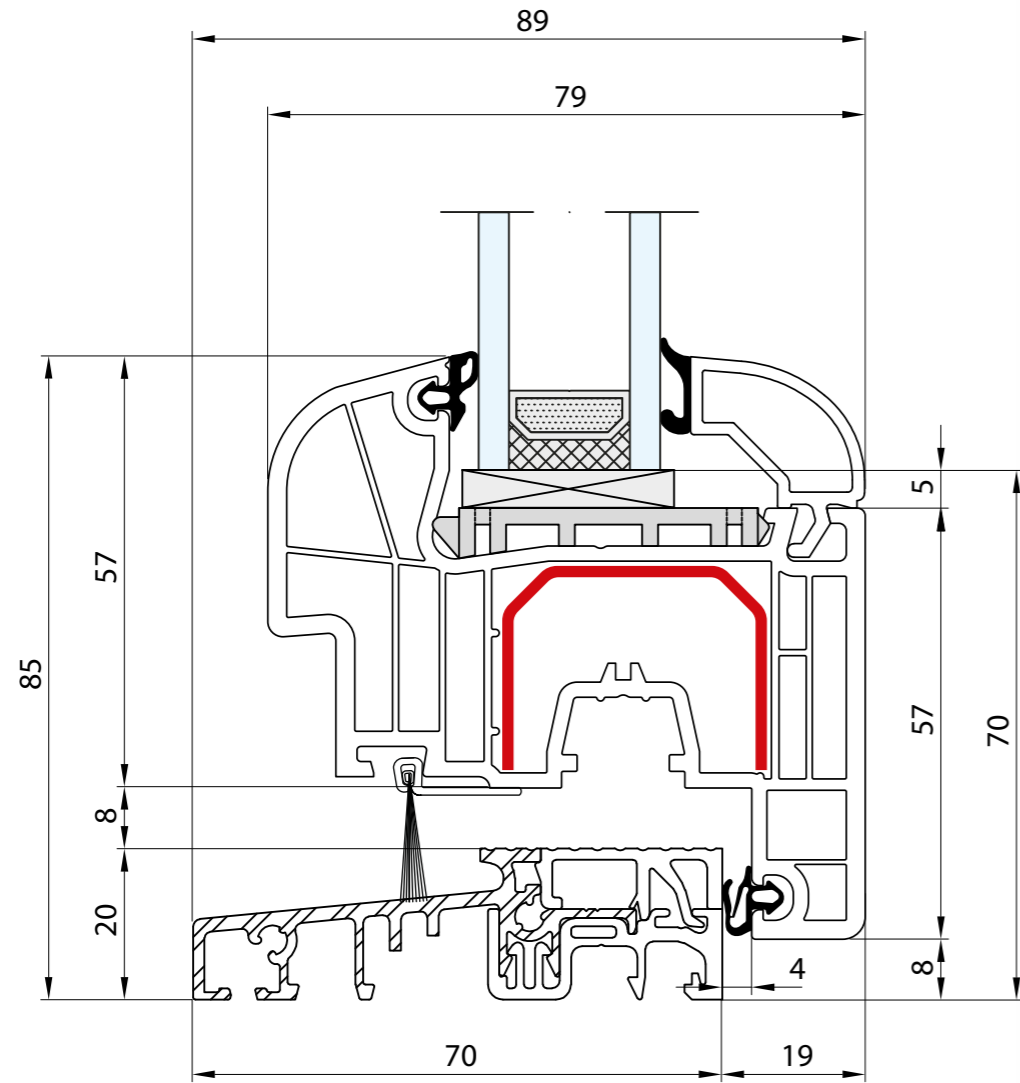



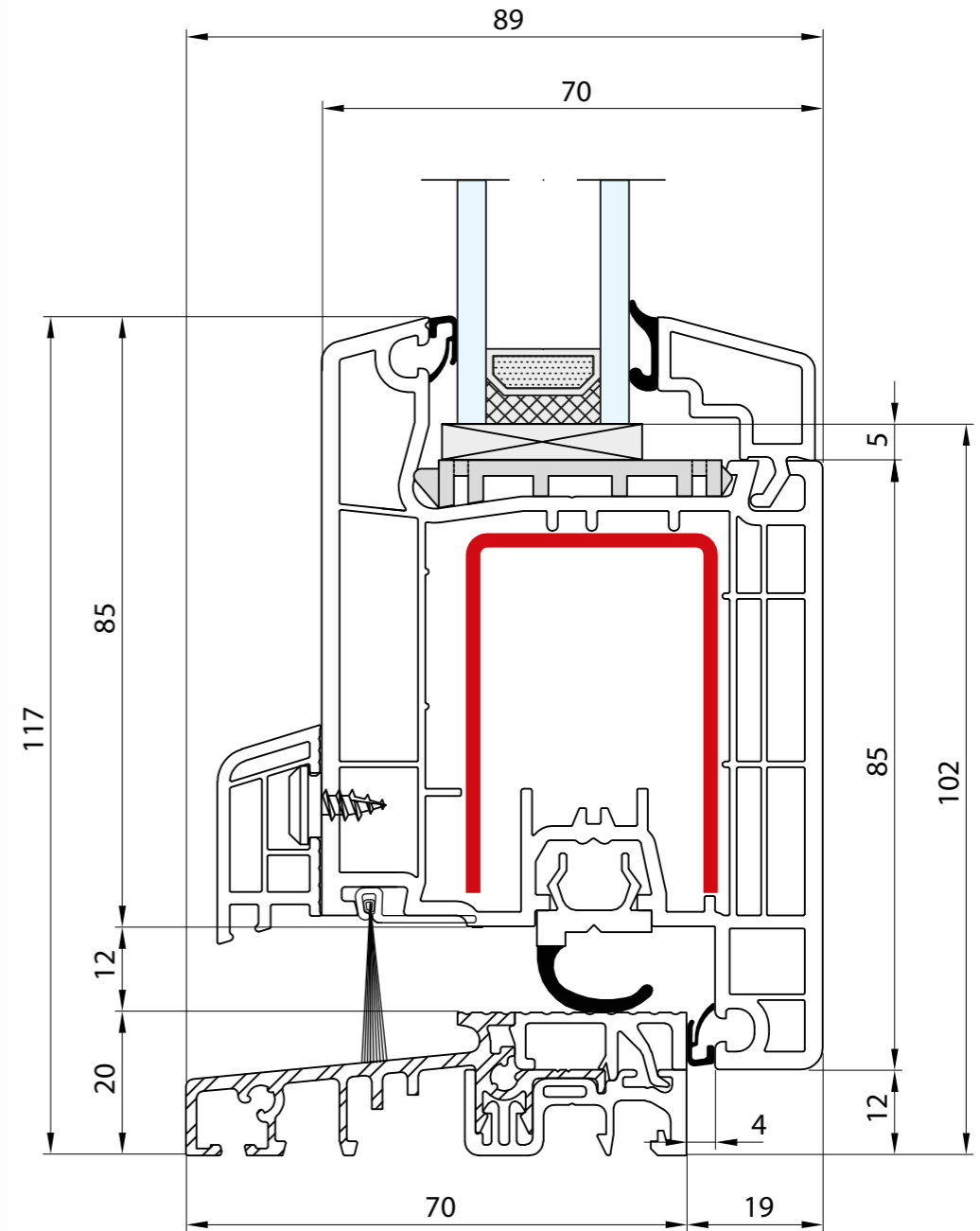
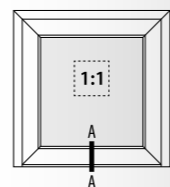

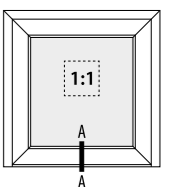

- Próg: 20 mm · Skrzydło: 77 mm
- Seuil: 20 mm · Vantail: 77 mm
- Threshold: 20 mm · Sash: 77 mm
- Schwelle: 20 mm · Flügel: 77 mm
- Soglia: 20 mm · Anta: 77 mm

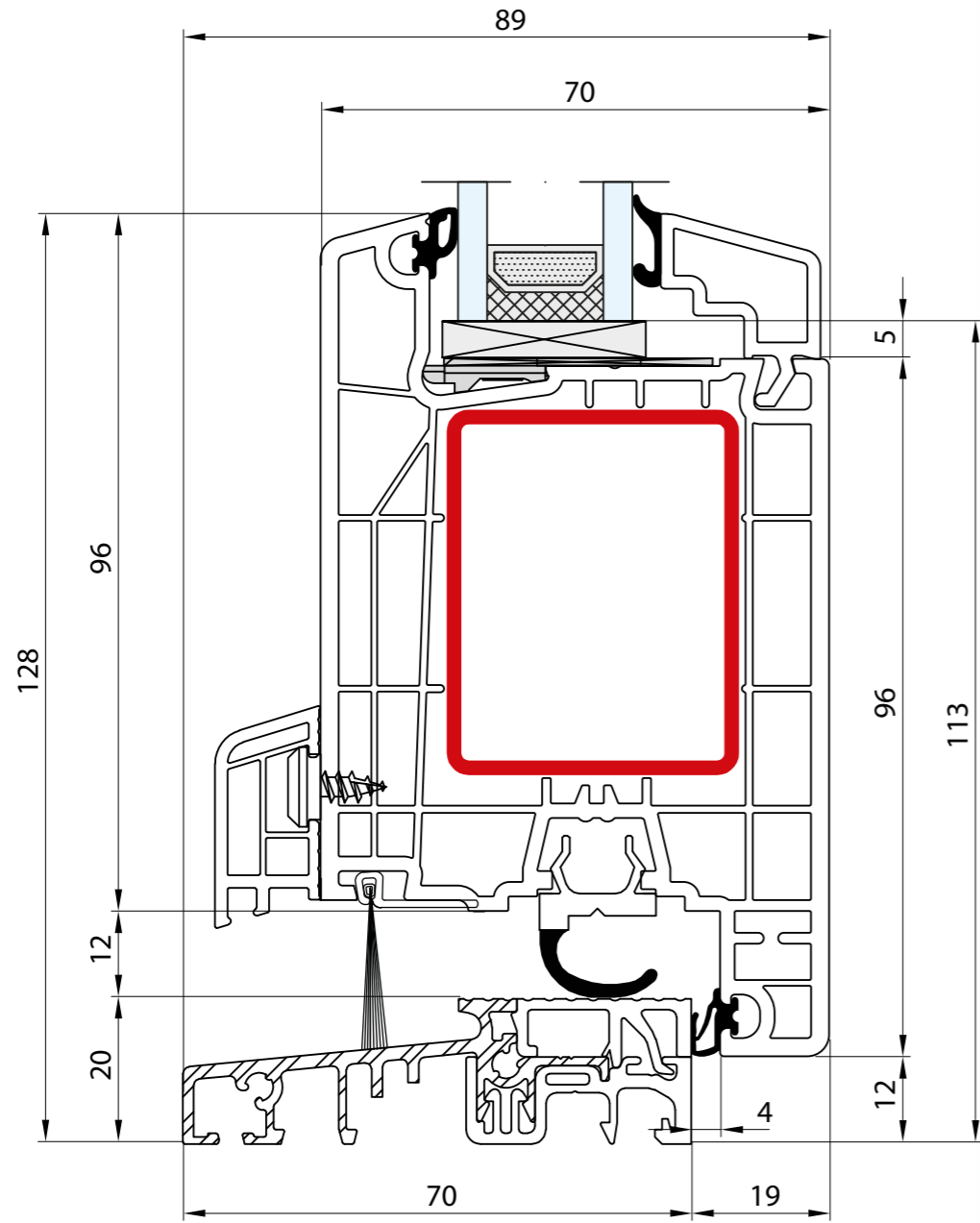

- Próg: 20 mm · Skrzydło: 105 mm
- Seuil: 20 mm · Vantail: 105 mm
- Threshold: 20 mm · Sash: 105 mm
- Schwelle: 20 mm · Flügel: 105 mm
- Soglia: 20 mm · Anta: 105 mm





-  Próg: 20 mm · Skrzydło: 116 mm
-  Seuil: 20 mm · Vantail: 116 mm
-  Threshold: 20 mm · Sash: 116 mm
-  Schwelle: 20 mm · Flügel: 116 mm
-  Soglia: 20 mm · Anta: 116 mm

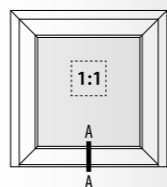

NORDLINE

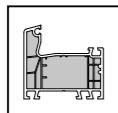

5



2

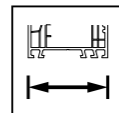

120

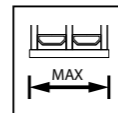

42

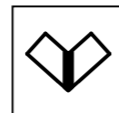

V SUPER SOLUTION



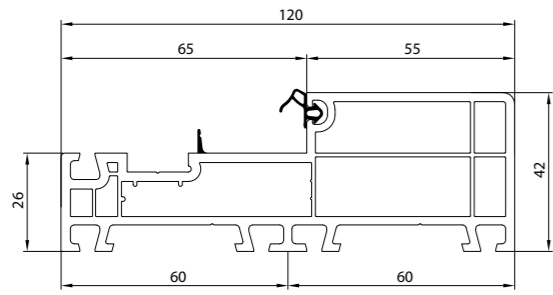

CL 140x90

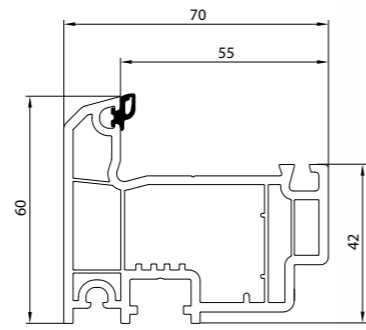

SL 140x93

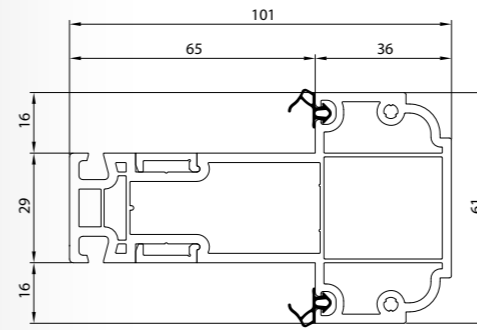

CL 140x98

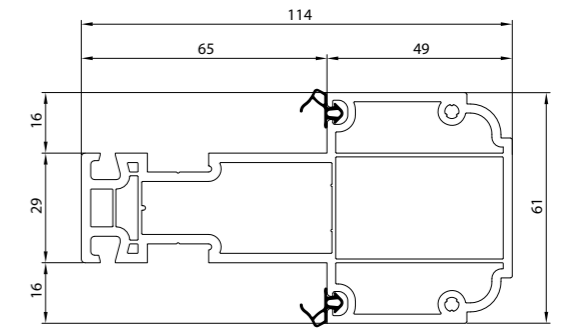

CL 140x99

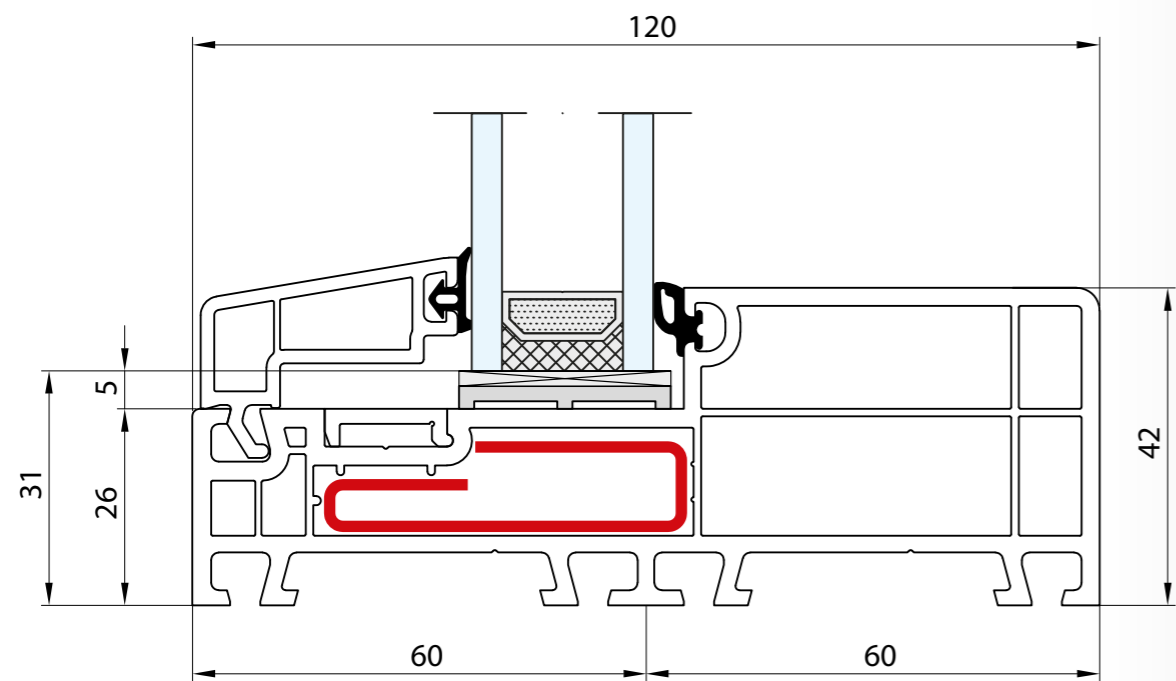

- Rama: 42 mm
- Dormant: 42 mm
- Frame: 42 mm
- Rahmen: 42 mm
- Telaio: 42 mm

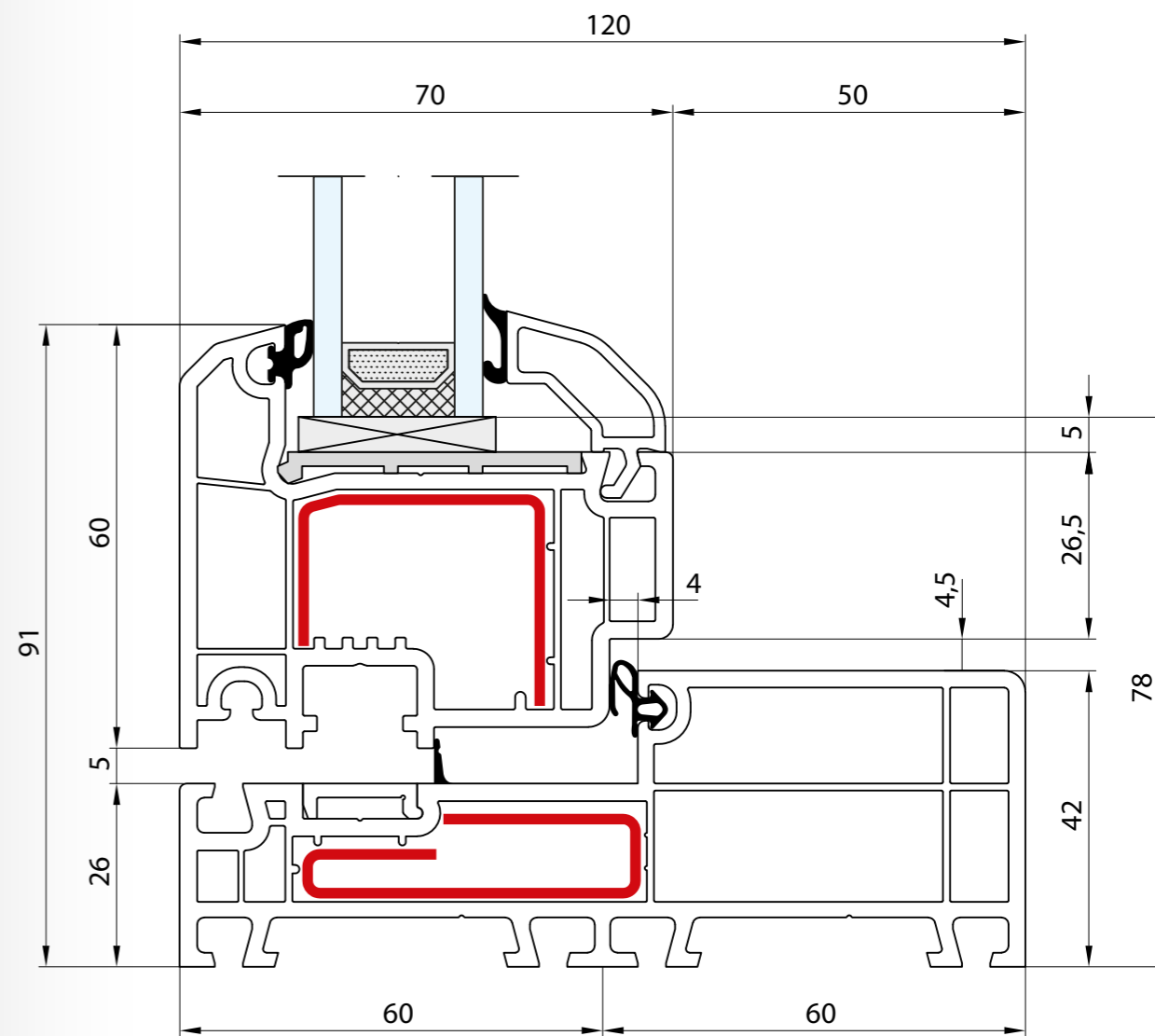
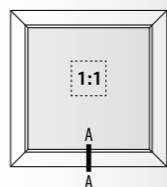



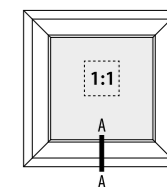

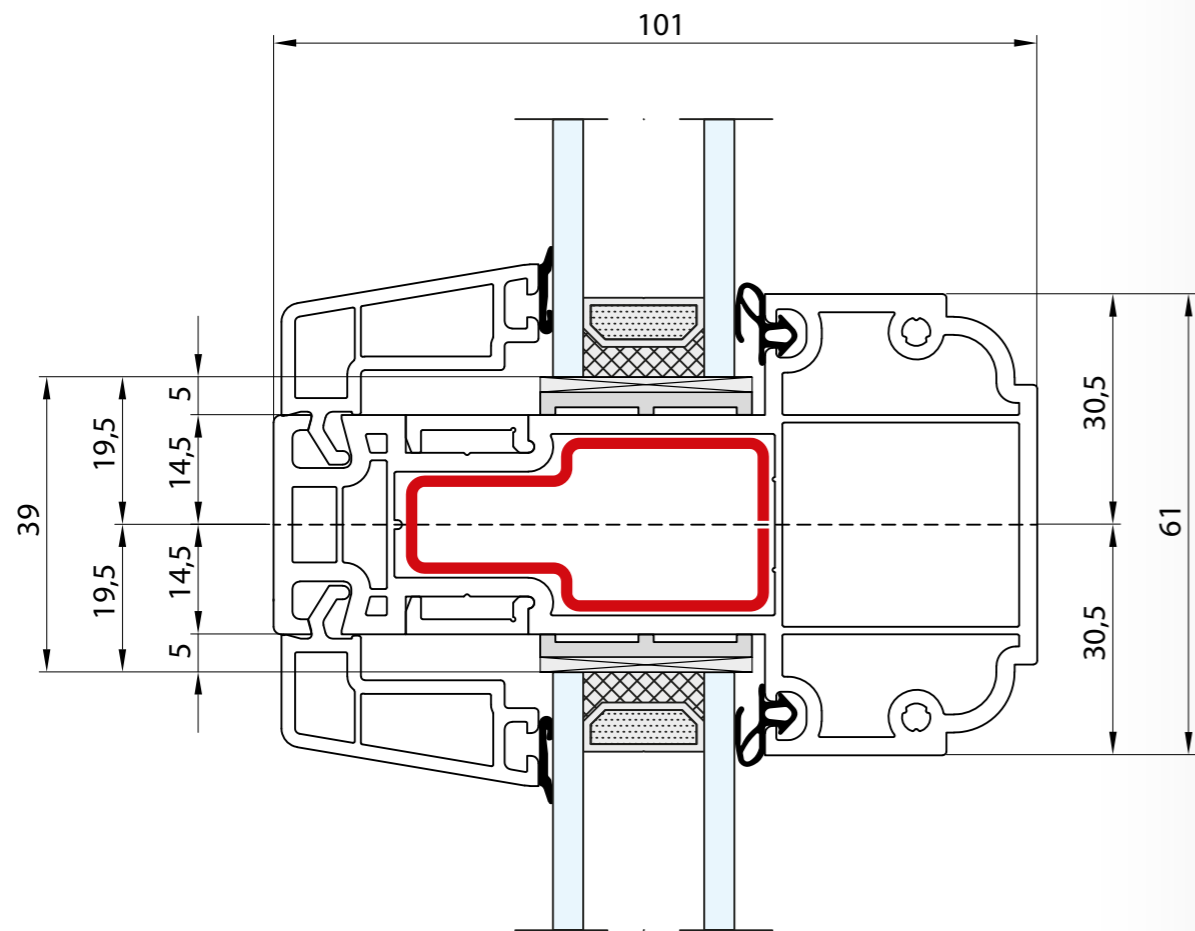

- Rama: 42 mm · Skrzydło: 60 mm
- Dormant: 42 mm · Vantail: 60 mm
- Frame: 42 mm · Sash: 60 mm
- Rahmen: 42 mm · Flügel: 60 mm
- Telaio: 42 mm · Anta: 60 mm

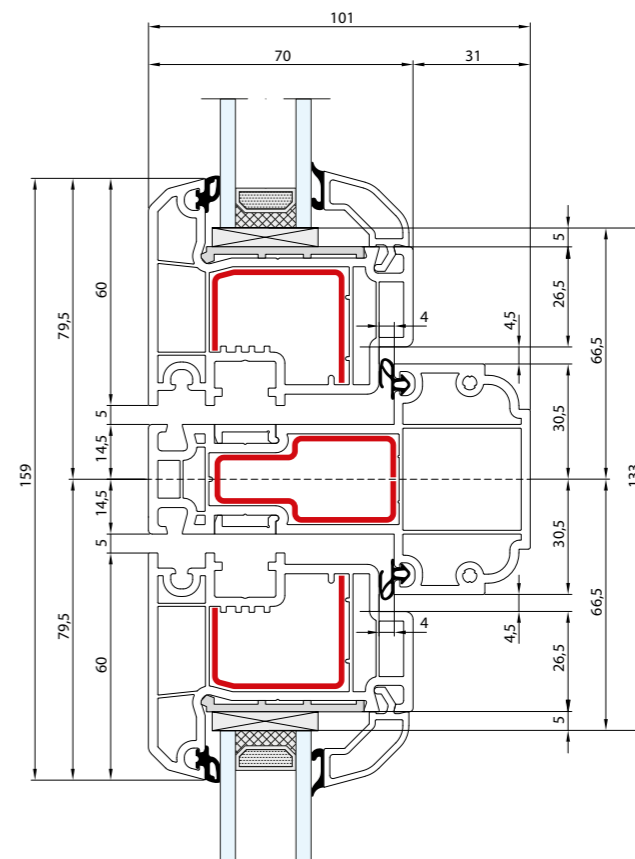
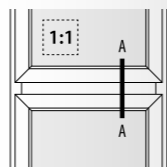



-  Poprzeczka: 61 mm
-  Traverse: 61 mm
-  Muntin bar: 61 mm
-  Kämpfer: 61 mm
-  Traverso: 61 mm



-  Poprzeczka: 61 mm · Skrzydło: 60 mm
-  Traverse: 61 mm · Vantail: 60 mm
-  Muntin bar: 61 mm · Sash: 60 mm
-  Kämpfer: 61 mm · Flügel: 60 mm
-  Traverso: 61 mm · Anta: 60 mm

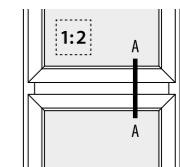

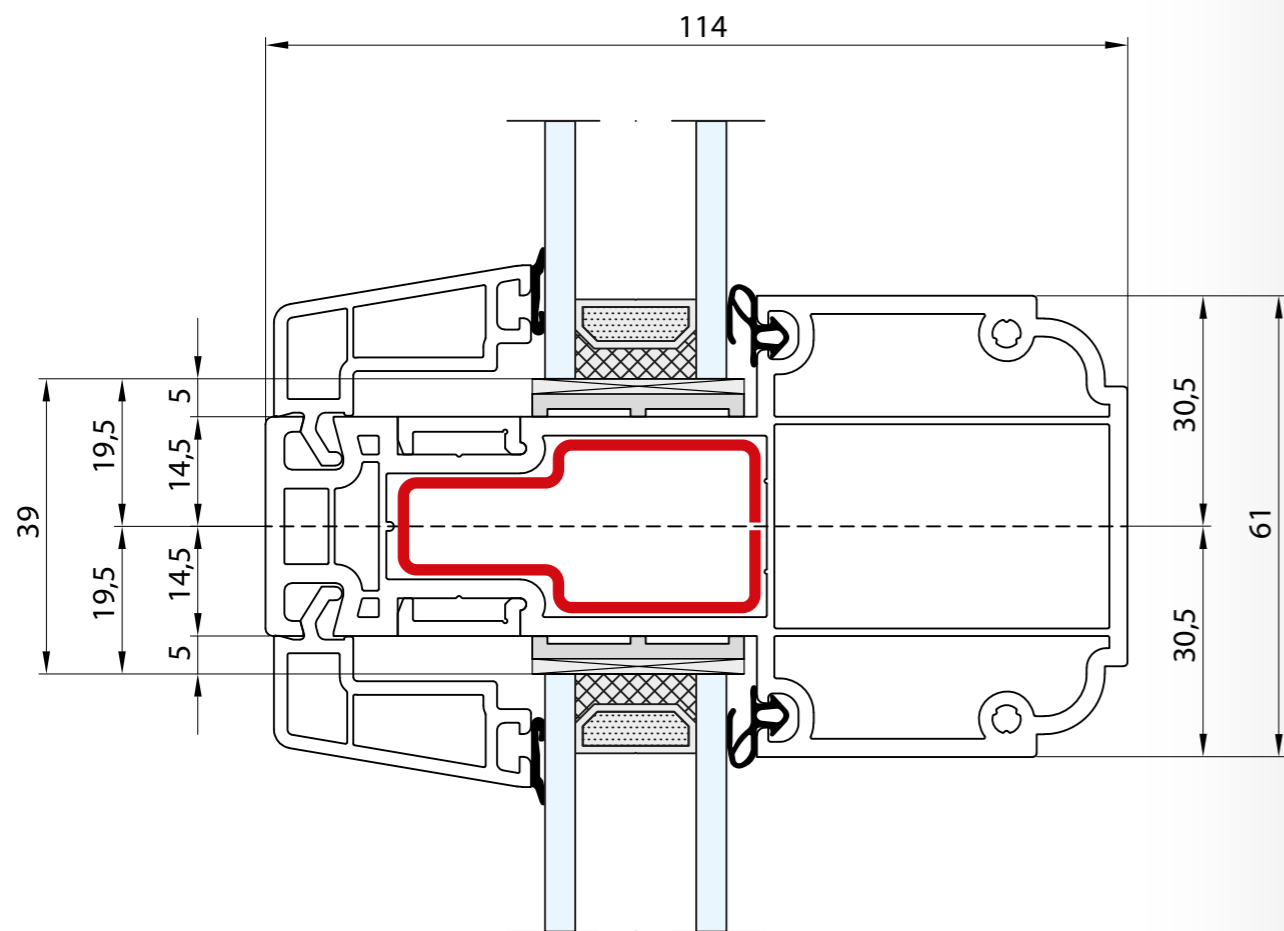

- Słupek stały: 61 mm
- Meneau fixe: 61 mm
- Fix post: 61 mm
- Festem Pfahl: 61 mm
- Montante fisso: 61 mm

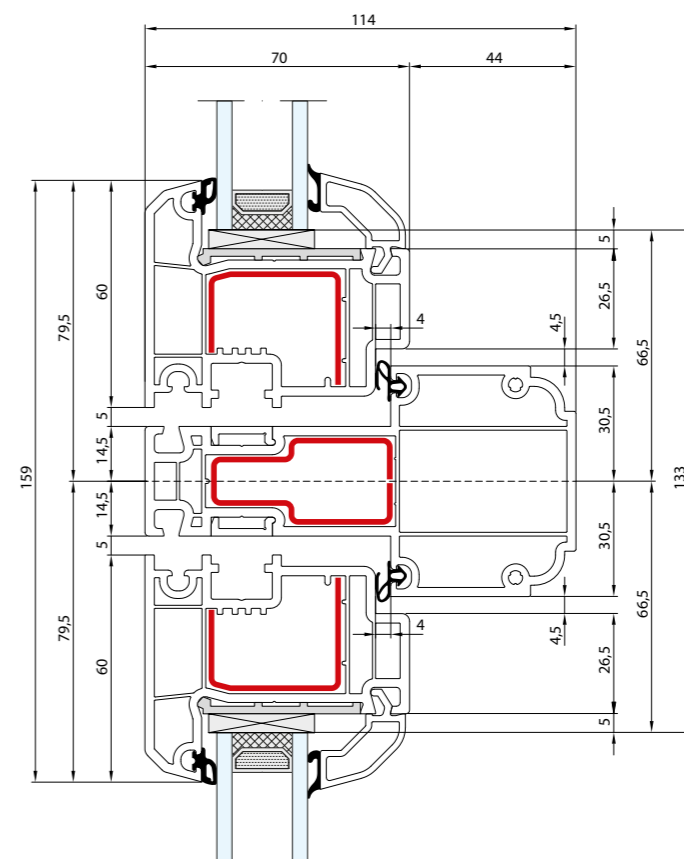
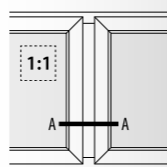



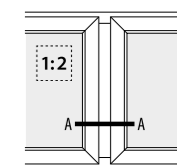

- Słupek stały: 61 mm · Skrzydło: 60 mm
- Meneau fixe: 61 mm · Vantail: 60 mm
- Fix post: 61 mm · Sash: 60 mm
- Festem Pfahl: 61 mm · Flügel: 60 mm
- Montante fisso: 61 mm · Anta: 60 mm

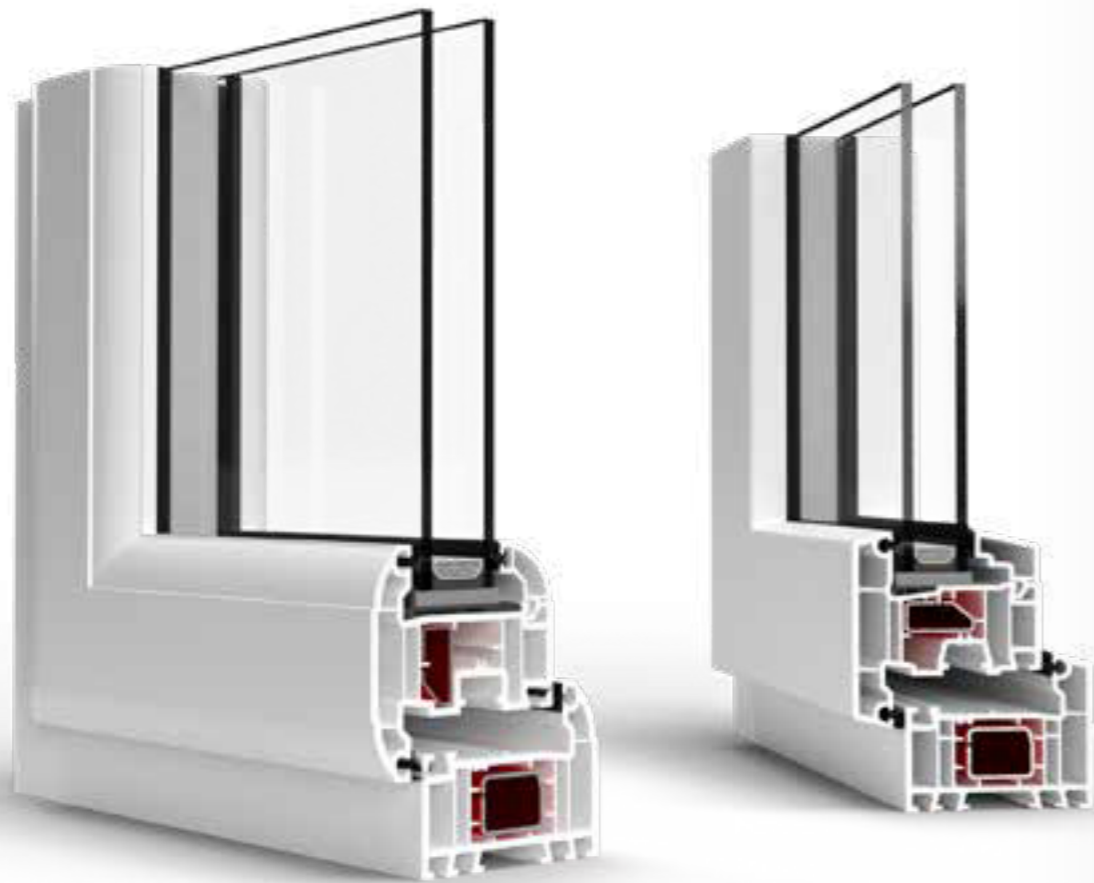

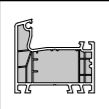
IDEAL 70 - CASEMENT

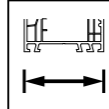
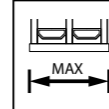

- 
5
- 
2
- 
70
- 
42
- 
STD

BLOCKPROFIL

MONOBLOCK

NORDLINE

IDEAL 70 - CASEMENET

BLOCKPROFIL

MONOBLOCK

NORDLINE

IDEAL 70 - CASEMENET

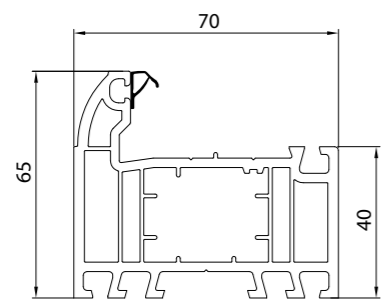

100x03

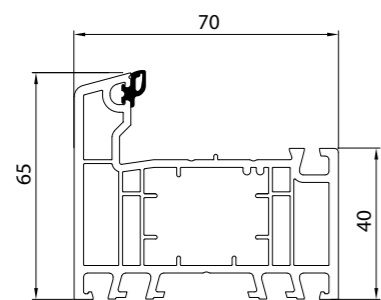

100x53

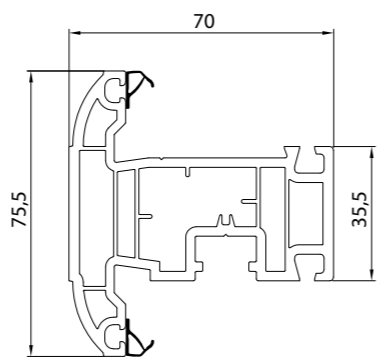

100x05

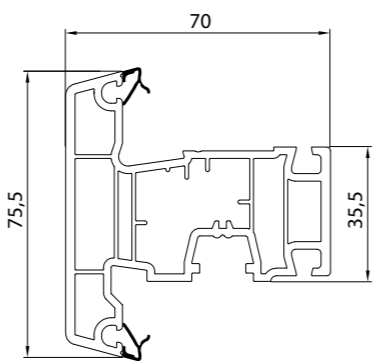

100x55

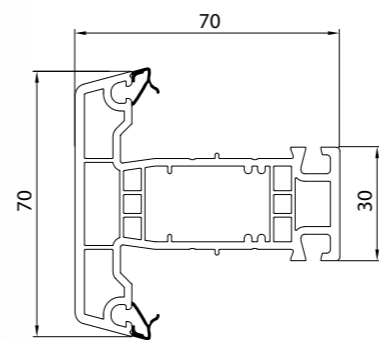

100x56

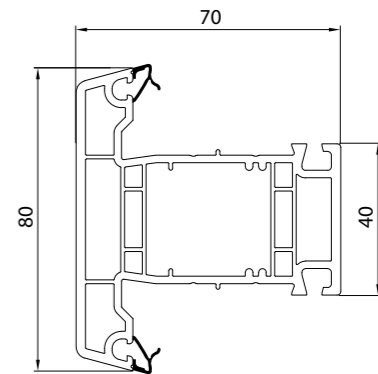

100x58

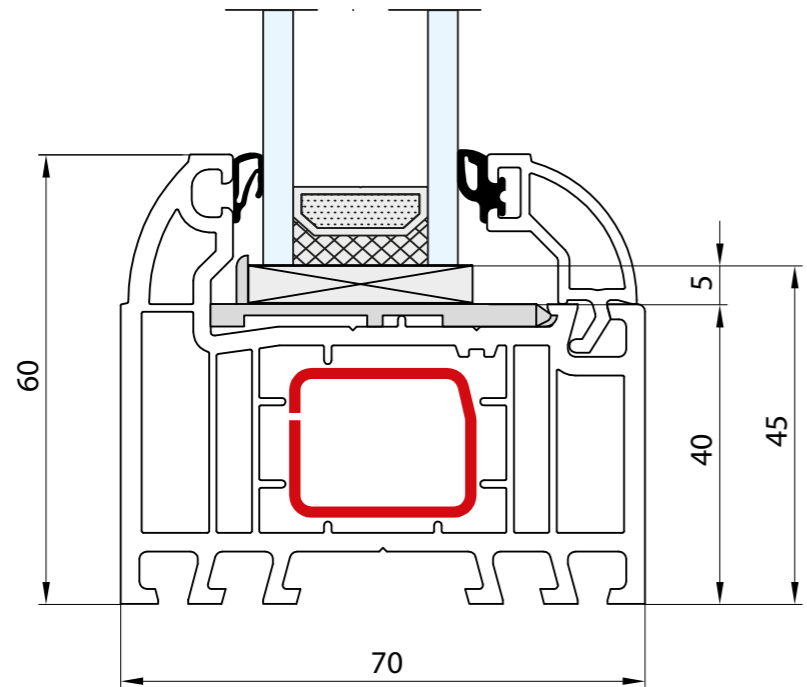

- Rama: 60 mm
- Dormant: 60 mm
- Frame: 60 mm
- Rahmen: 60 mm
- Telaio: 60 mm

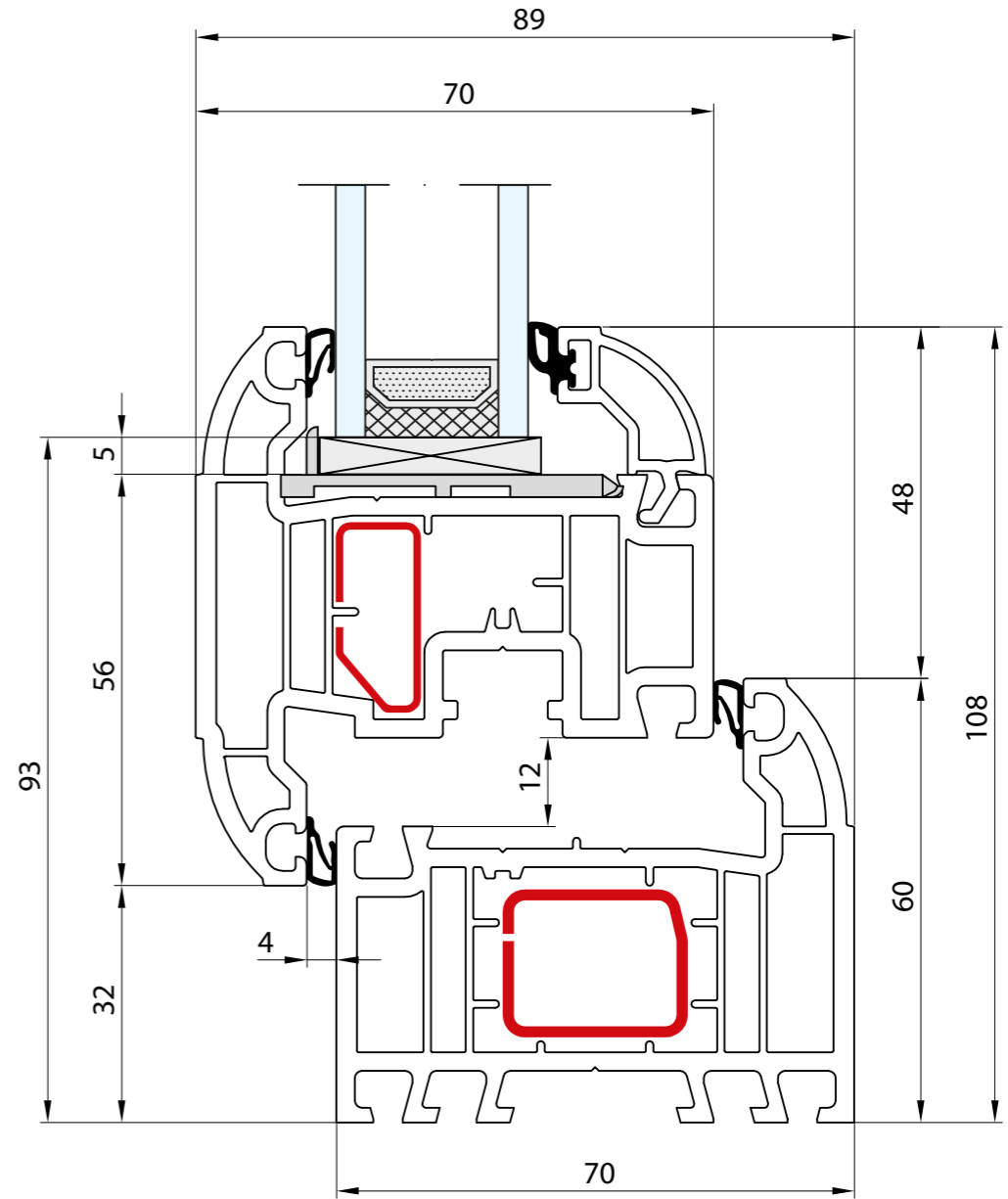
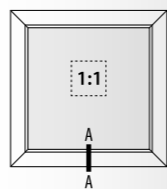

- Rama: 60 mm · Skrzydło: 76 mm
- Dormant: 60 mm · Vantail: 76 mm
- Frame: 60 mm · Sash: 76 mm
- Rahmen: 60 mm · Flügel: 76 mm
- Telaio: 60 mm · Anta: 76 mm

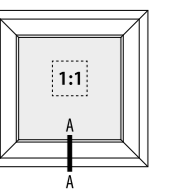

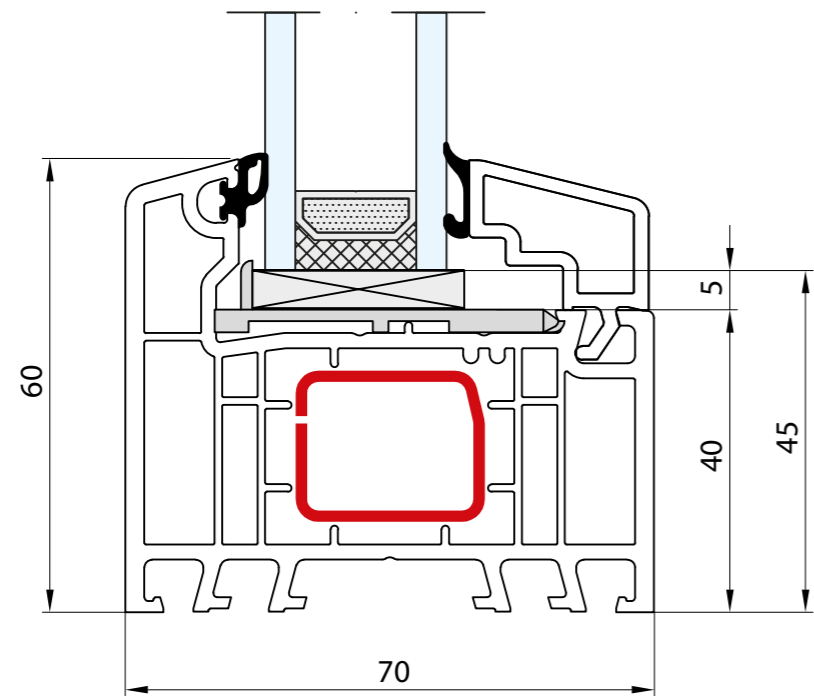



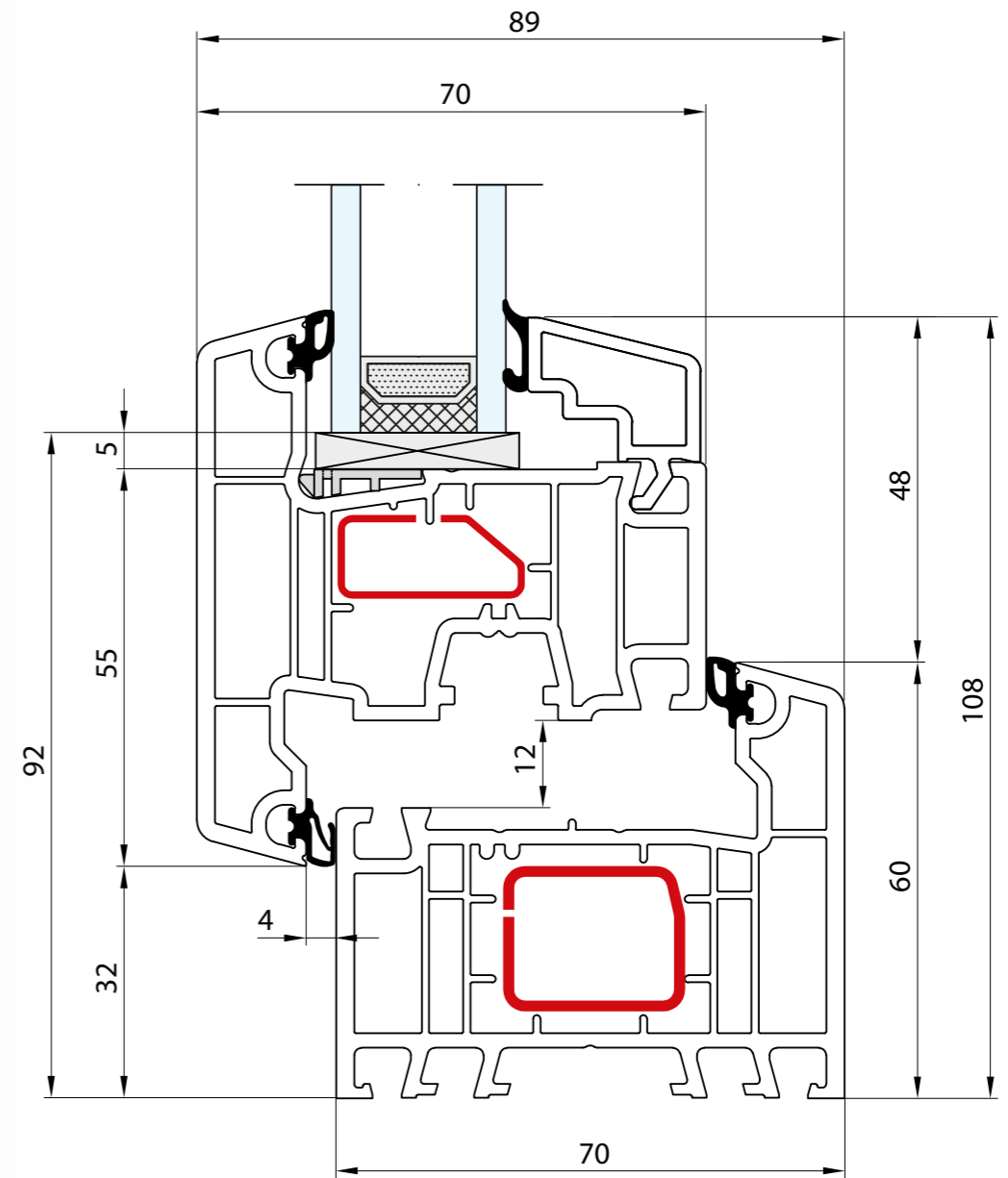
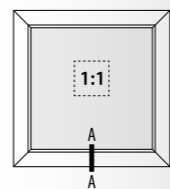

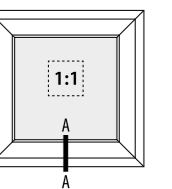

- Rama: 60 mm
- Dormant: 60 mm
- Frame: 60 mm
- Rahmen: 60 mm
- Telaio: 60 mm

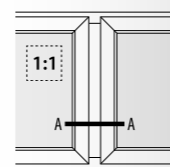
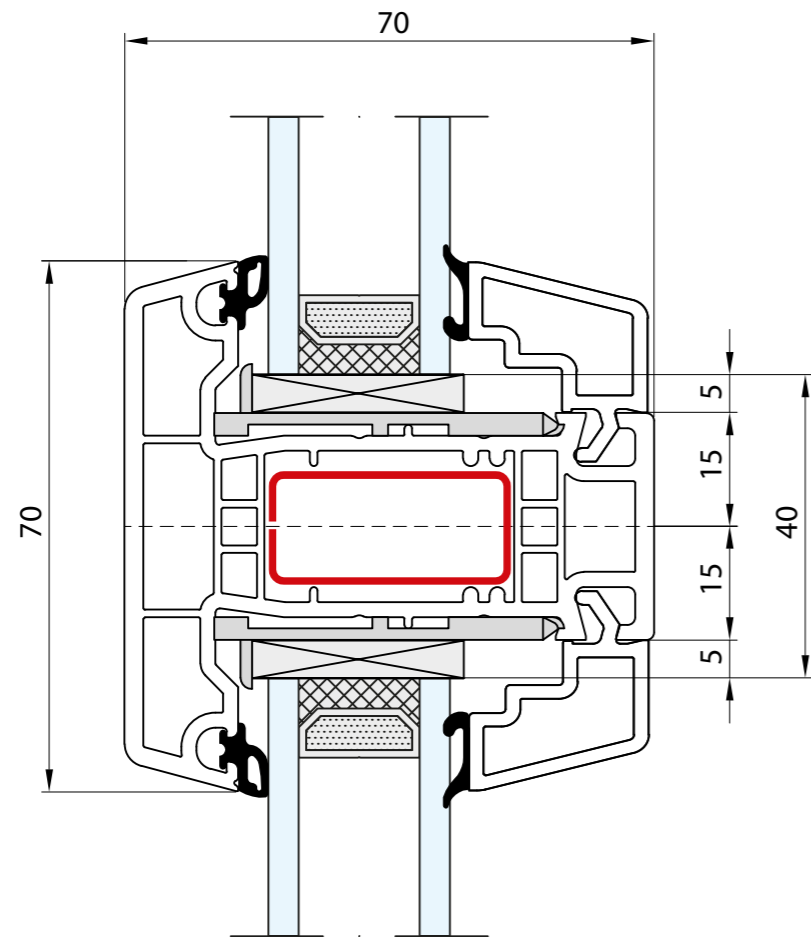







- Rama: 60 mm · Skrzydło: 75 mm
- Dormant: 60 mm · Vantail: 75 mm
- Frame: 60 mm · Sash: 75 mm
- Rahmen: 60 mm · Flügel: 75 mm
- Telaio: 60 mm · Anta: 75 mm

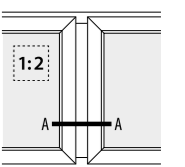
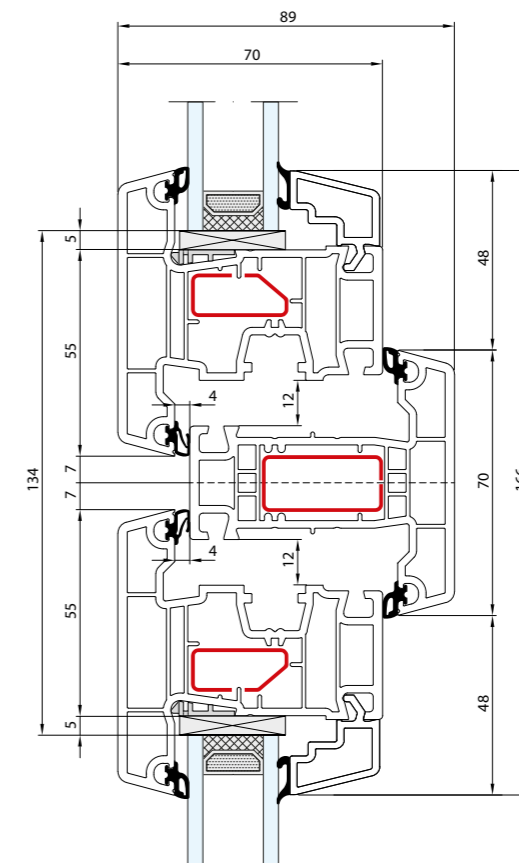







-  Słupek stały: 70 mm
-  Meneau fixe: 70 mm
-  Fix post: 70 mm
-  Festem Pfahl: 70 mm
-  Montante fisso: 70 mm

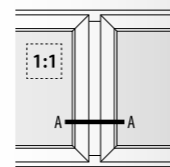
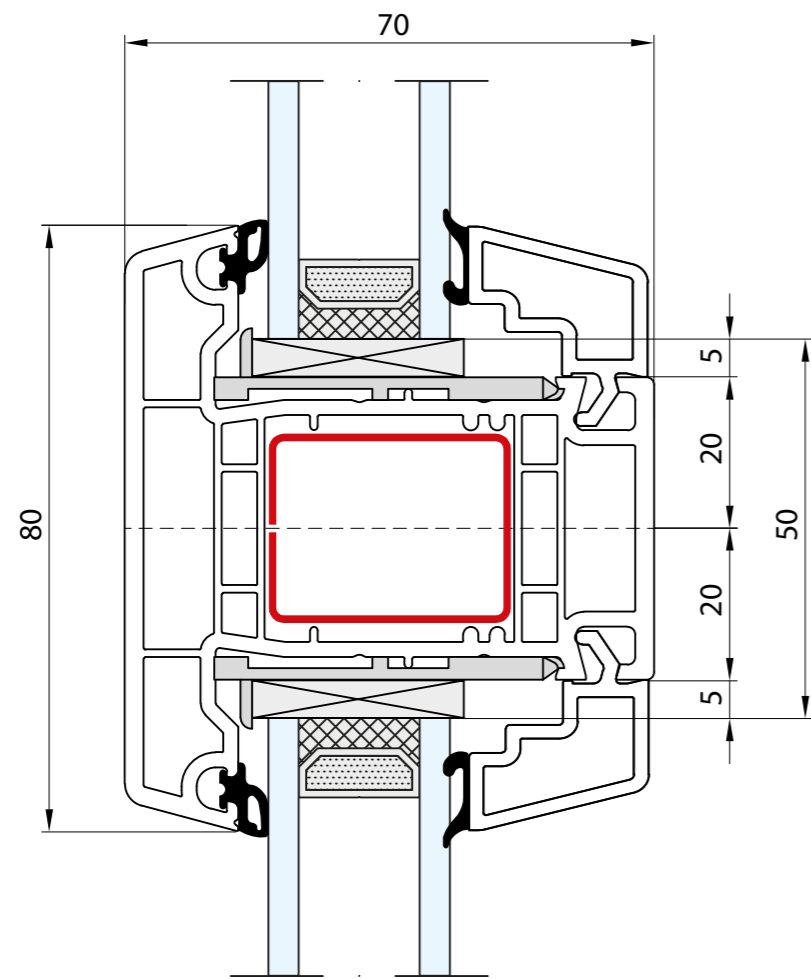

-  Słupek stały: 70 mm · Skrzydło: 75 mm
-  Meneau fixe: 70 mm · Vantail: 75 mm
-  Fix post: 70 mm · Sash: 75 mm
-  Festem Pfahl: 70 mm · Flügel: 75 mm
-  Montante fisso: 70 mm · Anta: 75 mm



-  Słupek stały: 80 mm
-  Meneau fixe: 80 mm
-  Fix post: 80 mm
-  Festem Pfahl: 80 mm
-  Montante fissa: 80 mm

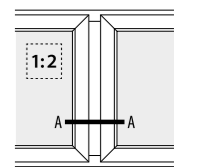
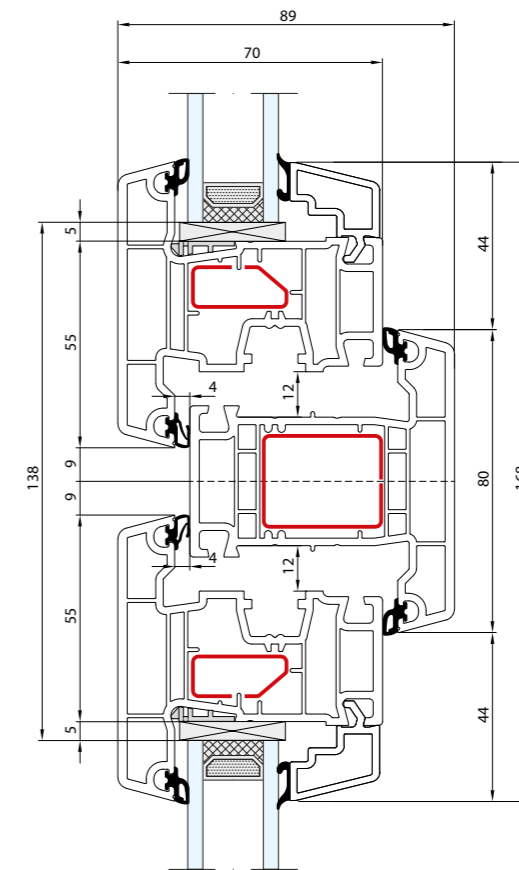

-  Słupek stały: 80 mm · Skrzydło: 75 mm
-  Meneau fixe: 80 mm · Vantail: 75 mm
-  Fix post: 80 mm · Sash: 75 mm
-  Festem Pfahl: 80 mm · Flügel: 75 mm
-  Montante fissa: 80 mm · Anta: 75 mm

EASY SLIDE

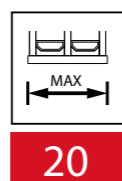
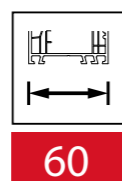
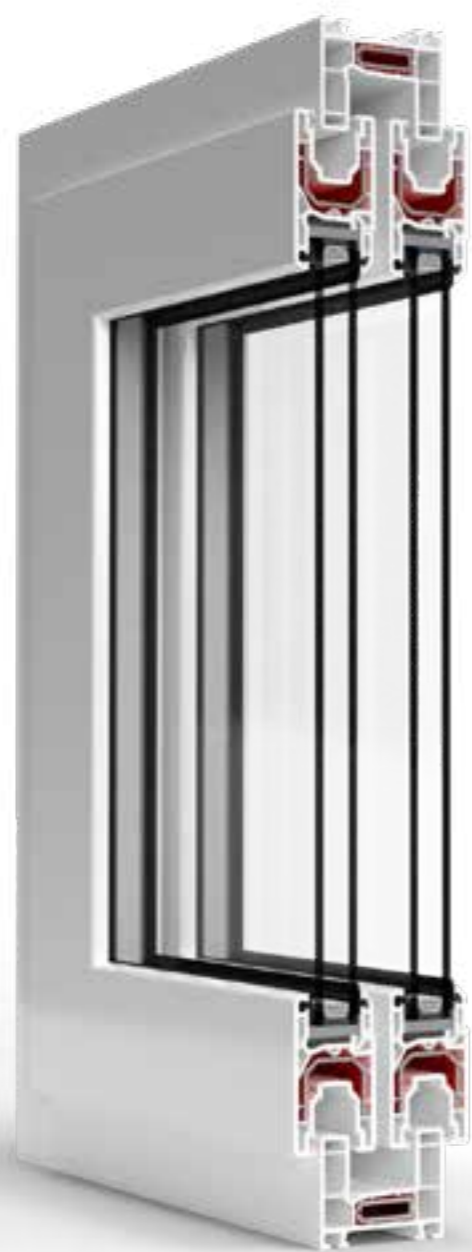

EASY SLIDE +

MULTI SLIDE

SMART SLIDE

HST 70

HST 85

EASY SLIDE +

MULTI SLIDE

SMART SLIDE

HST 70

HST 85

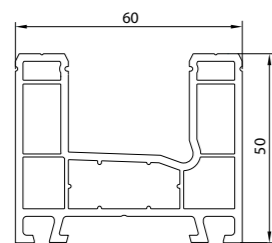



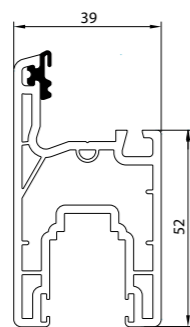

100069

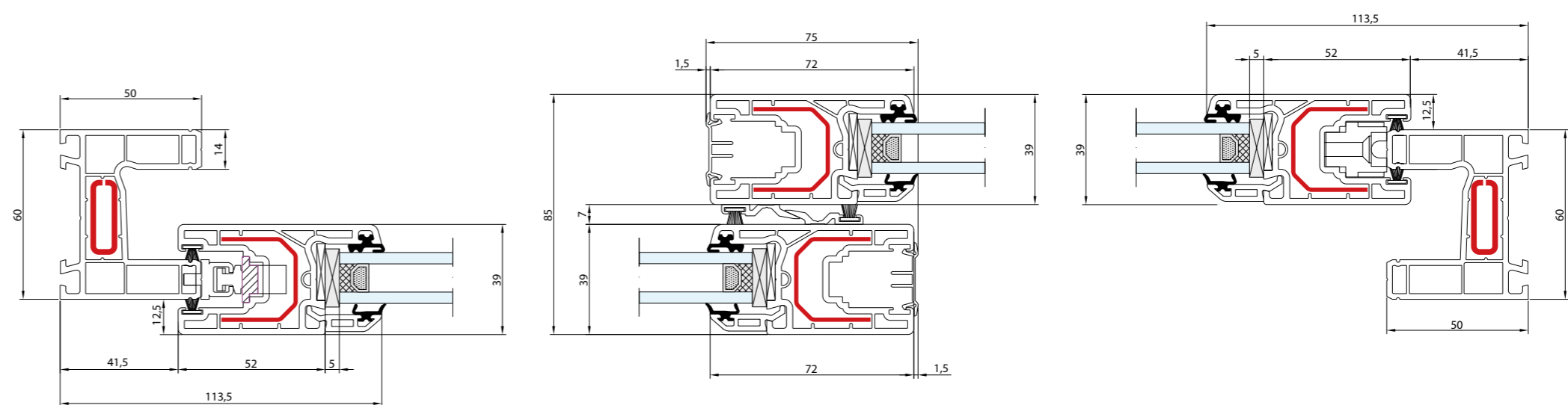

100072



-  Schemat A - Przekrój poziomy · Rama: 50 mm · Skrzydło: 72 mm
 Schéma A - Coupe horizontale · Dormant: 50 mm · Vantail: 72 mm
 Schema A - Doorsnede horizontaal · Frame: 50 mm · Sash: 72 mm
 Schema A - Wagerechter Schnitt · Rahmen: 50 mm · Flügel: 72 mm
 Schema A - Sezione orizzontale · Telaio: 50 mm · Anta: 72 mm

1:2

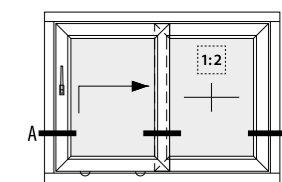

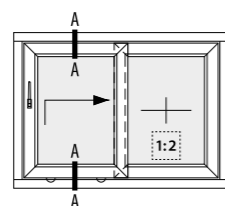
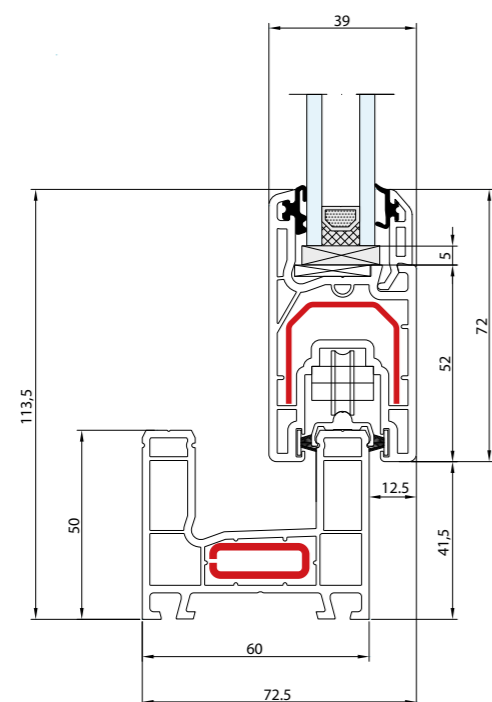
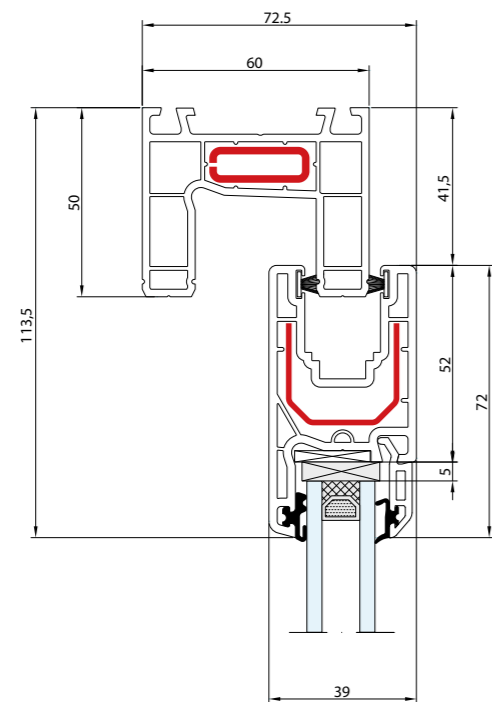

- Schemat A - Przekrój pionowy · Rama: 50 mm · Skrzydło: 72 mm
- Schéma A - Coupe verticale · Dormant: 50 mm · Vantail: 72 mm
- Schema A - Doorsnede verticaal · Frame: 50 mm · Sash: 72 mm
- Schema A - Senkrechter Schnitt · Rahmen: 50 mm · Flügel: 72 mm
- Schema A - Sezione verticale · Telaio: 50 mm · Anta: 72 mm

EASY SLIDE

MULTI SLIDE

SMART SLIDE

HST 70

HST 85

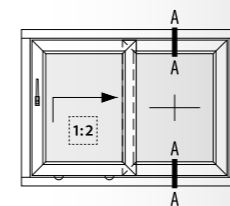
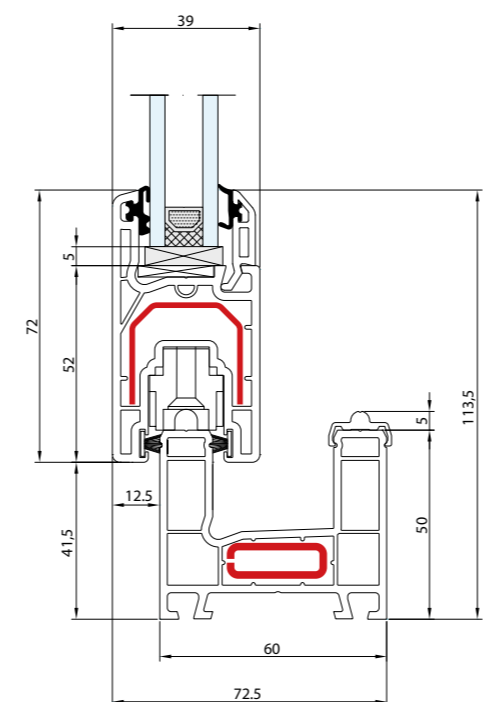
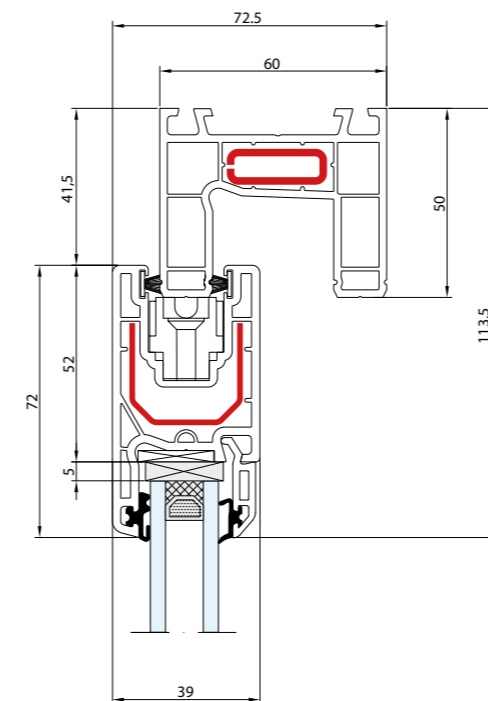

- Schemat A - Przekrój pionowy · Rama: 50 mm · Skrzydło: 72 mm
- Schéma A - Coupe verticale · Dormant: 50 mm · Vantail: 72 mm
- Schema A - Doorsnede verticaal · Frame: 50 mm · Sash: 72 mm
- Schema A - Senkrechter Schnitt · Rahmen: 50 mm · Flügel: 72 mm
- Schema A - Sezione verticale · Telaio: 50 mm · Anta: 72 mm

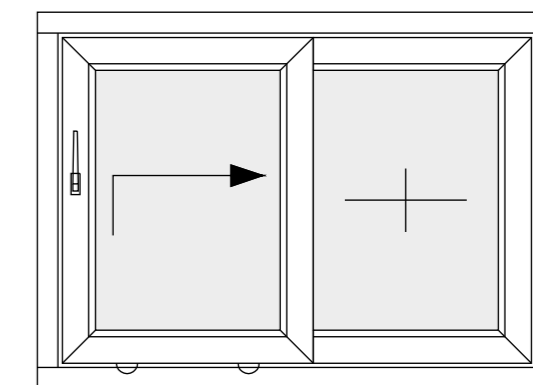

A

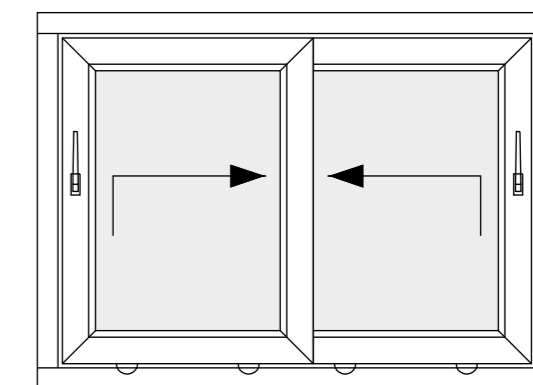

D

- Schemat
- Schéma
- Schema
- Schema
- Schema

EASY SLIDE

MULTI SLIDE

SMART SLIDE

HST 70

HST 85

MULTI SLIDE

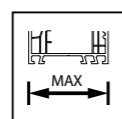

170

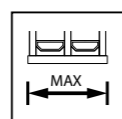

33

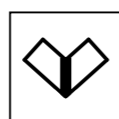

V SUPER SOLUTION



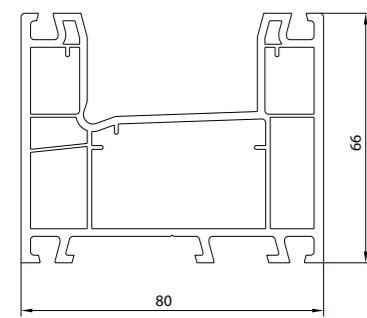

100090

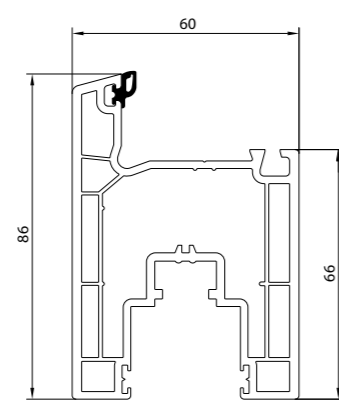

100092

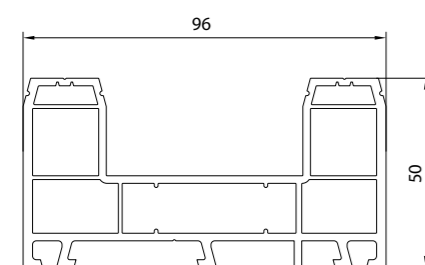

100097

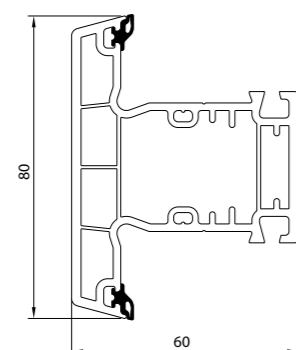



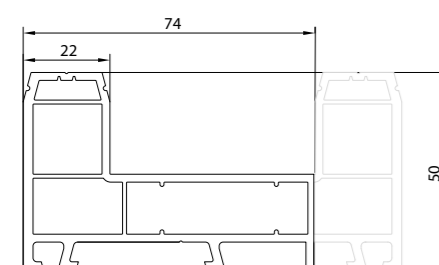

120041

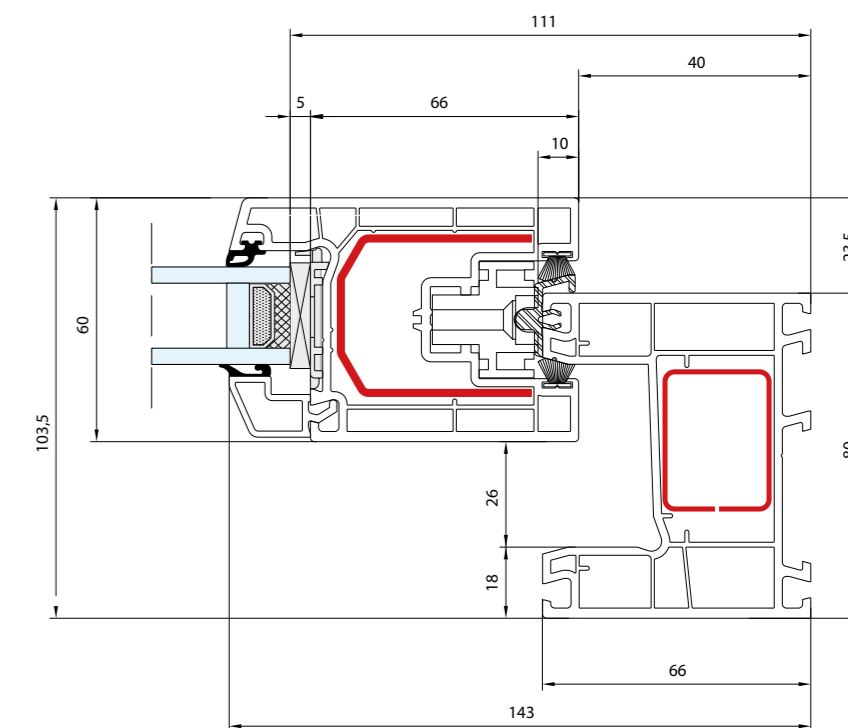
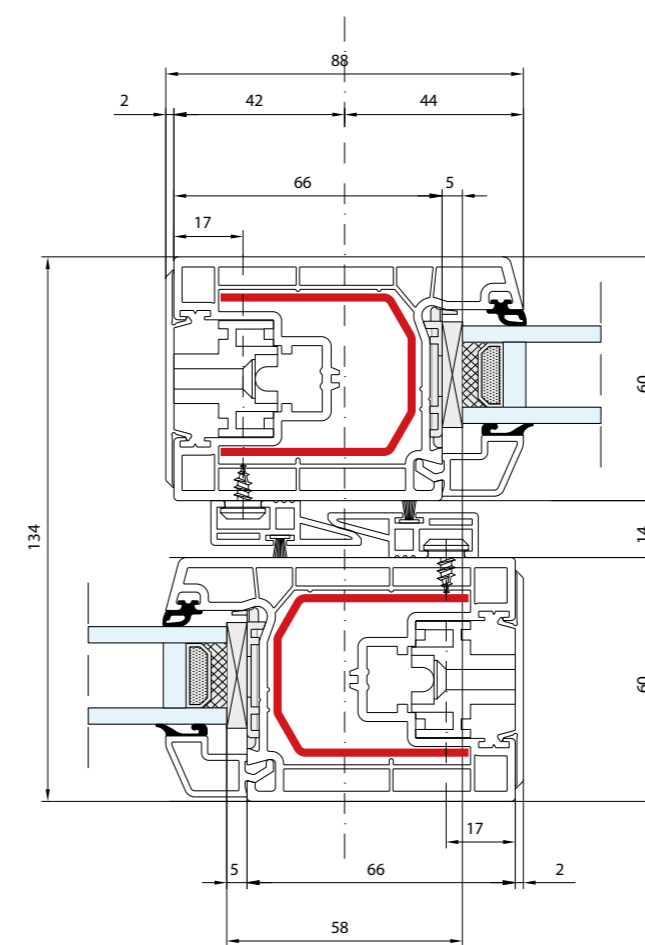
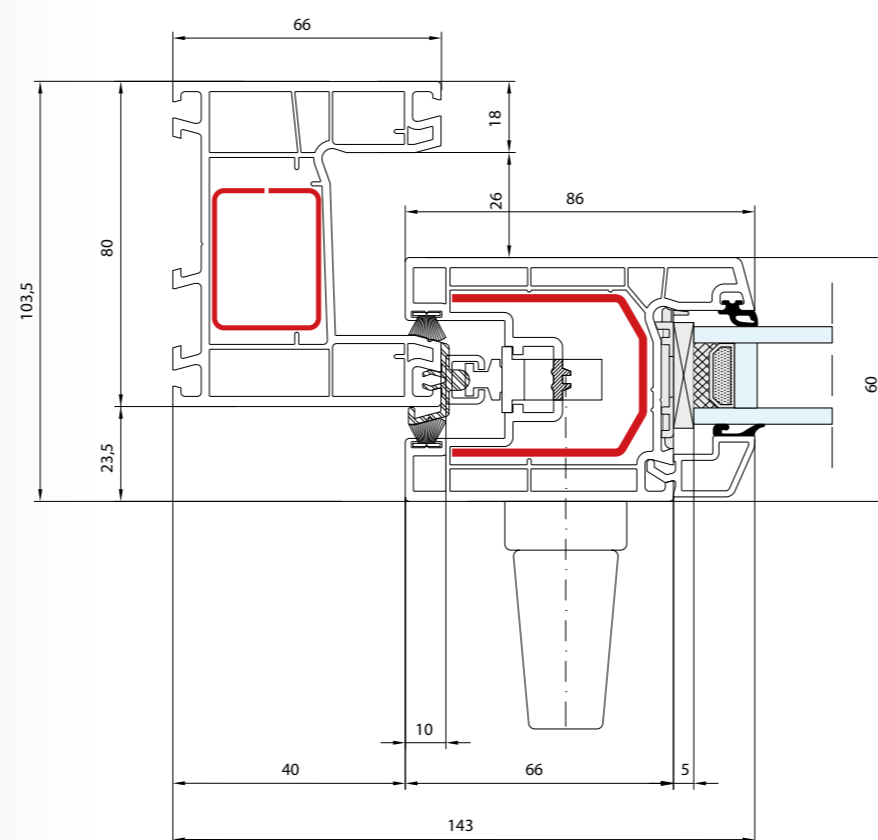

100098



-  Schemat A - Przekrój poziomy · Rama: 66 mm · Skrzydło: 86 mm
-  Schéma A - Coupe horizontale · Dormant: 66 mm · Vantail: 86 mm
-  Schema A - Doorsnede horizontaal · Frame: 66 mm · Sash: 86 mm
-  Schema A - Wagerechter Schnitt · Rahmen: 66 mm · Flügel: 86 mm
-  Schema A - Sezione orizzontale · Telaio: 66 mm · Anta: 86 mm

1:2

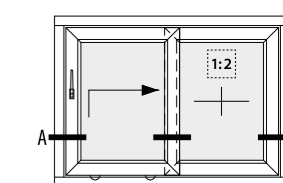

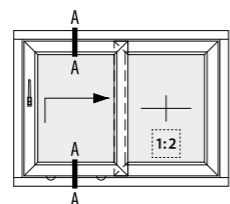
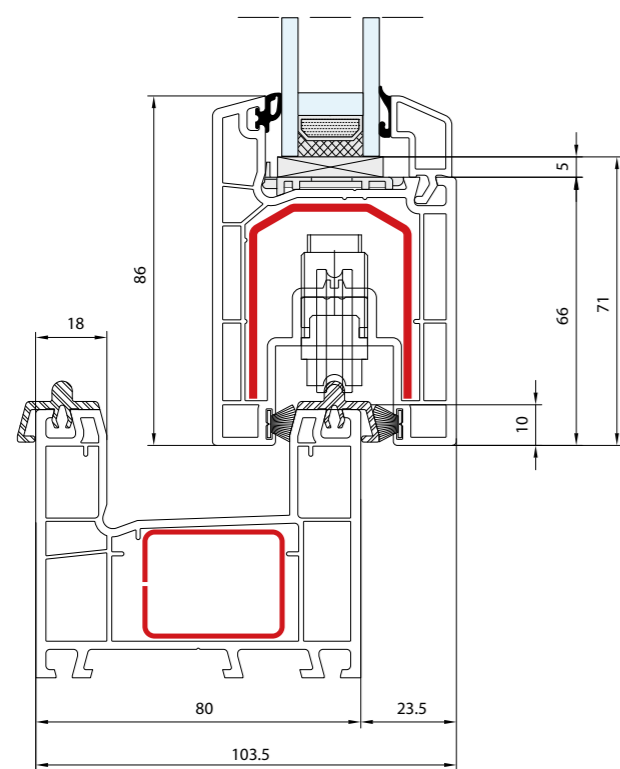
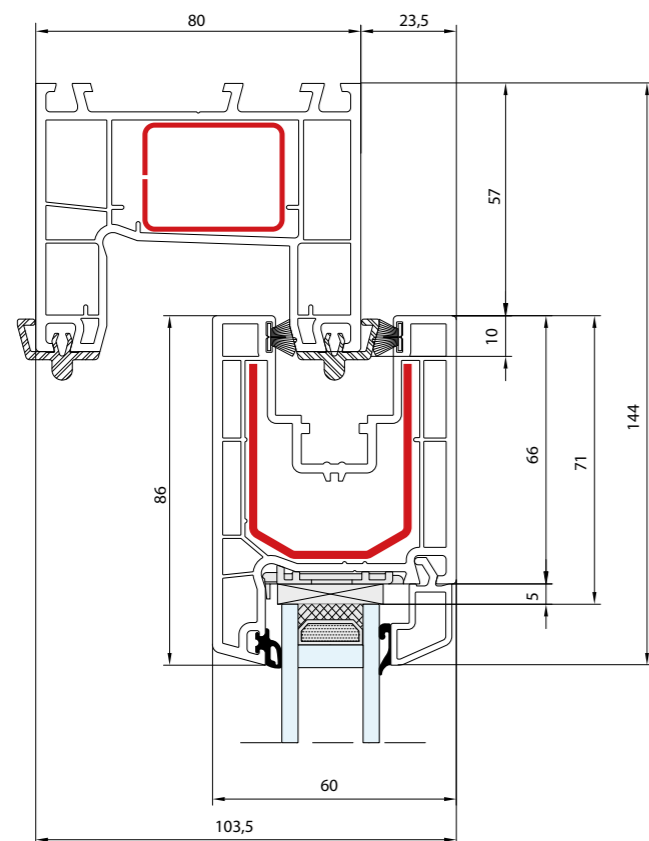

- Schemat A - Przekrój pionowy · Rama: 66 mm · Skrzydło: 86 mm
- Schéma A - Coupe verticale · Dormant: 66 mm · Vantail: 86 mm
- Schema A - Doorsnede verticaal · Frame: 66 mm · Sash: 86 mm
- Schema A - Senkrechter Schnitt · Rahmen: 66 mm · Flügel: 86 mm
- Schema A - Sezione verticale · Telaio: 66 mm · Anta: 86 mm

EASY SLIDE

MULTI SLIDE

SMART SLIDE

HST 70

HST 85

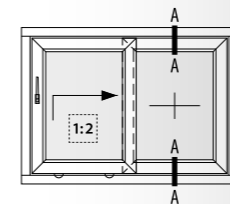
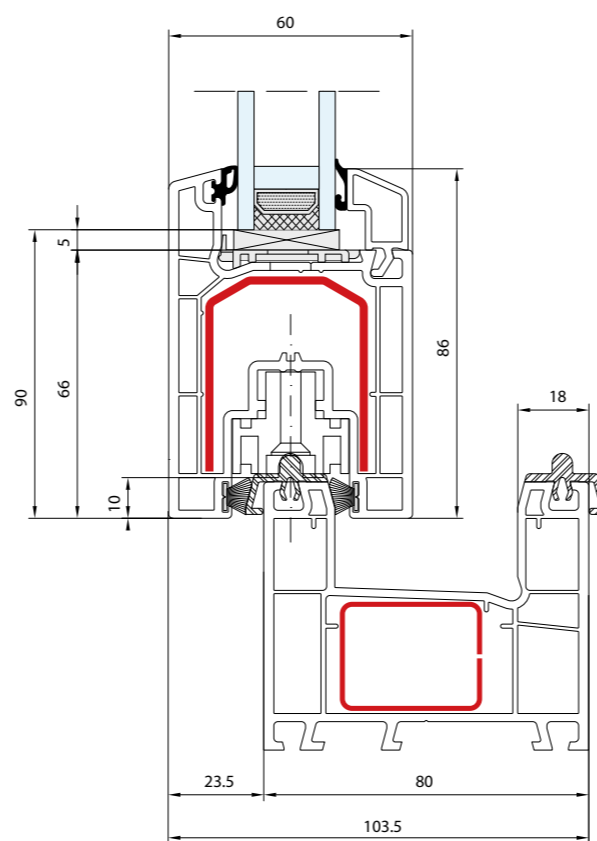
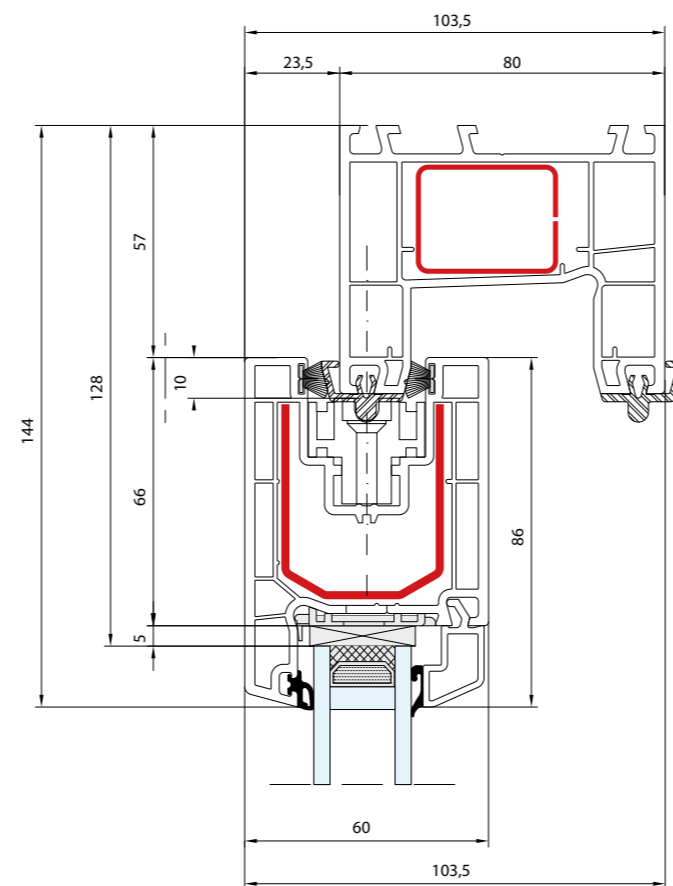

- Schemat A - Przekrój pionowy · Rama: 66 mm · Skrzydło: 86 mm
- Schéma A - Coupe verticale · Dormant: 66 mm · Vantail: 86 mm
- Schema A - Doorsnede verticaal · Frame: 66 mm · Sash: 86 mm
- Schema A - Senkrechter Schnitt · Rahmen: 66 mm · Flügel: 86 mm
- Schema A - Sezione verticale · Telaio: 66 mm · Anta: 86 mm

EASY SLIDE

MULTI SLIDE

SMART SLIDE

HST 70

HST 85

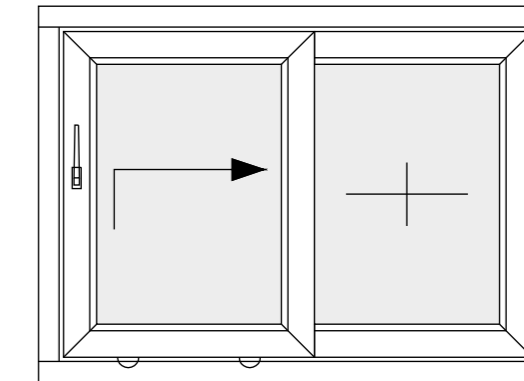

A

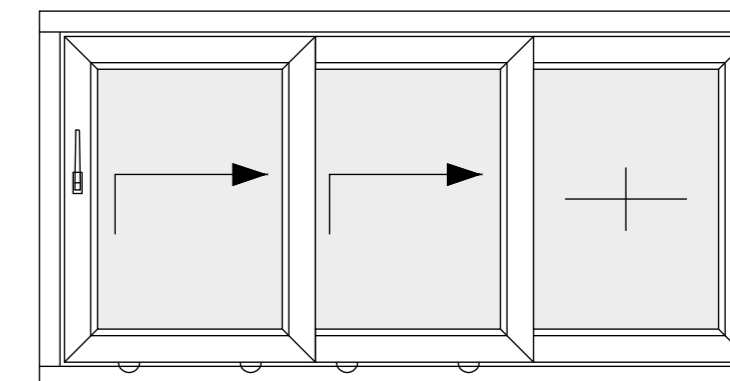

An

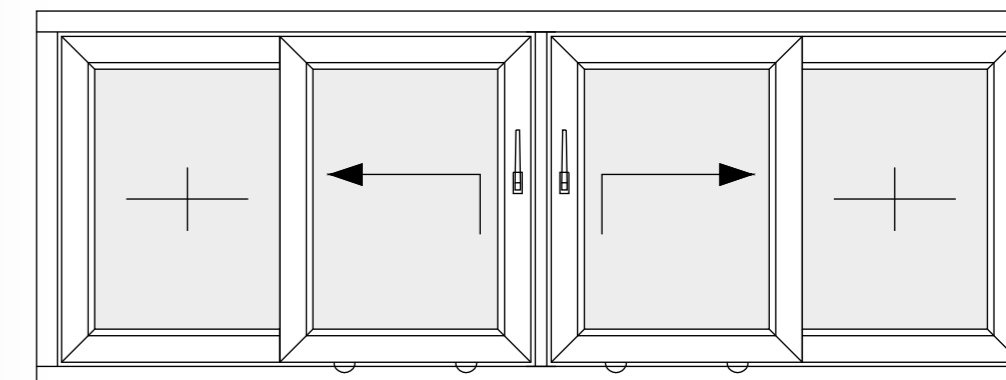

C

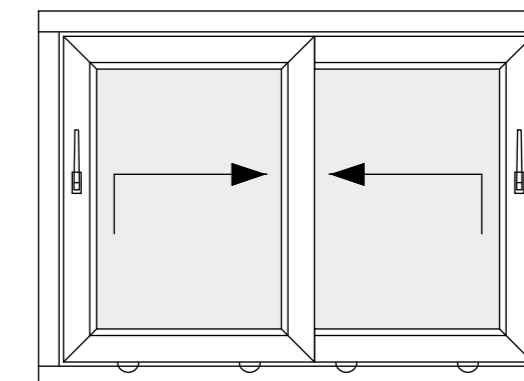

D

- Schemat
- Schéma
- Schema
- Schema
- Schema

EASY SLIDE

MULTI SLIDE

SMART SLIDE

HST 70

HST 85

SMART SLIDE

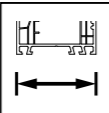
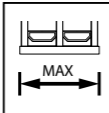
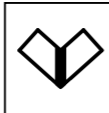

		
140	42	SUPER SOLUTION



EASY SLIDE

MULTI SLIDE

SMART SLIDE

HST 70

HST 85

EASY SLIDE

MULTI SLIDE

SMART SLIDE

HST 70

HST 85

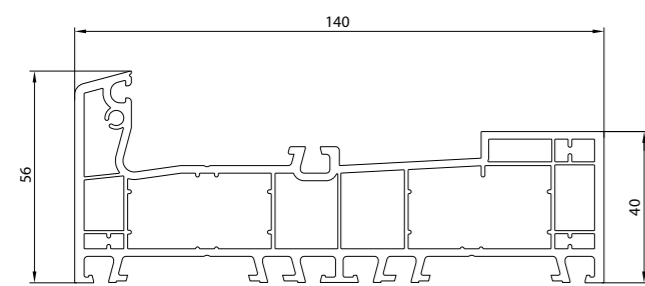

100091

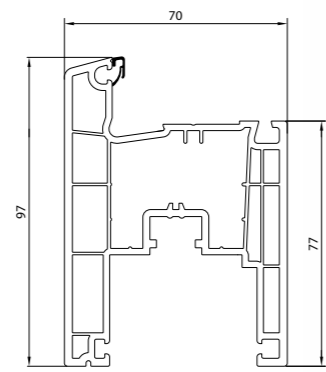

100094

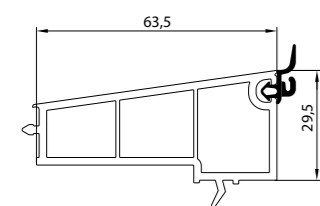

100291

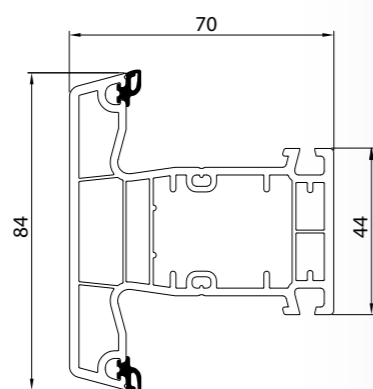



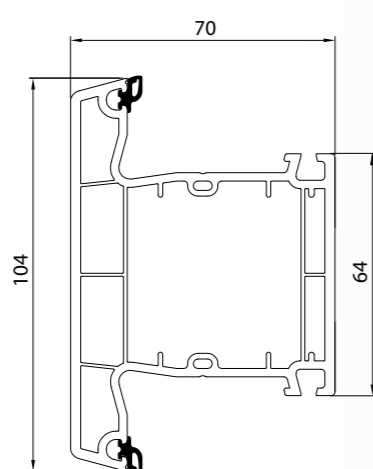

140x41

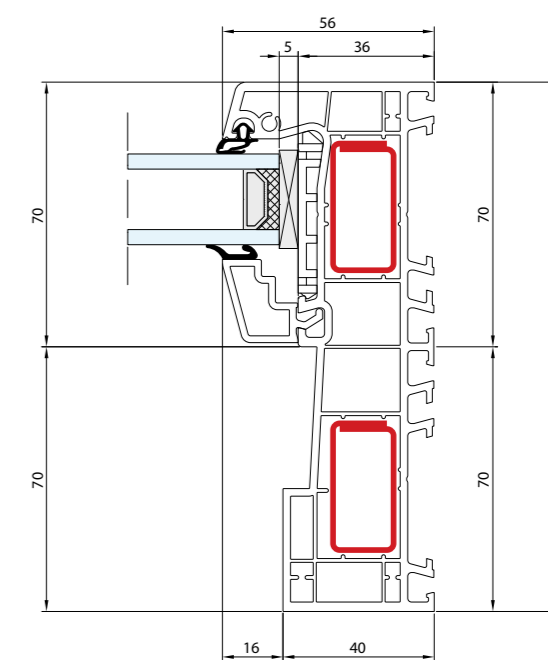
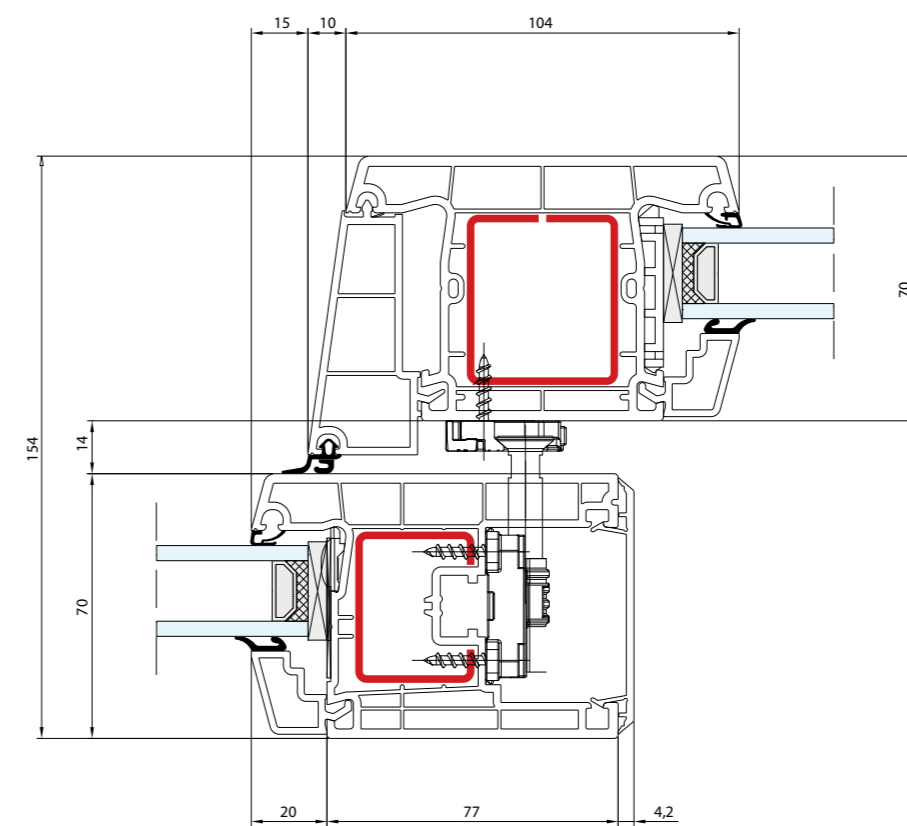
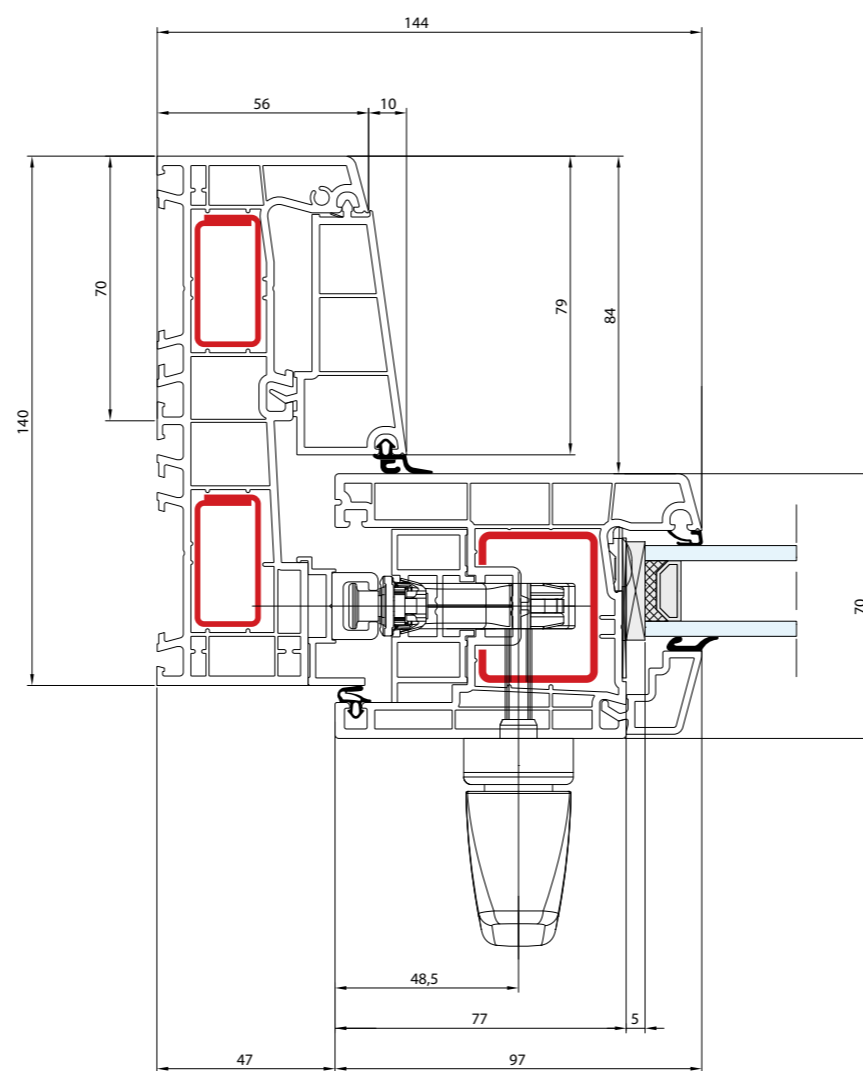

140x45



-  Schemat A - Przekrój poziomy · Rama: 56 mm · Skrzydło: 97 mm
-  Schéma A - Coupe horizontale · Dormant: 56 mm · Vantail: 97 mm
-  Schema A - Doorsnede horizontaal · Frame: 56 mm · Sash: 97 mm
-  Schema A - Wagerechter Schnitt · Rahmen: 56 mm · Flügel: 97 mm
-  Schema A - Sezione orizzontale · Telaio: 56 mm · Anta: 97 mm

1:2

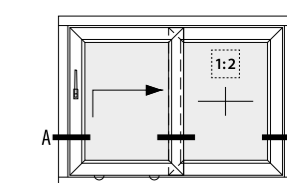

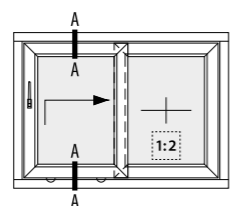
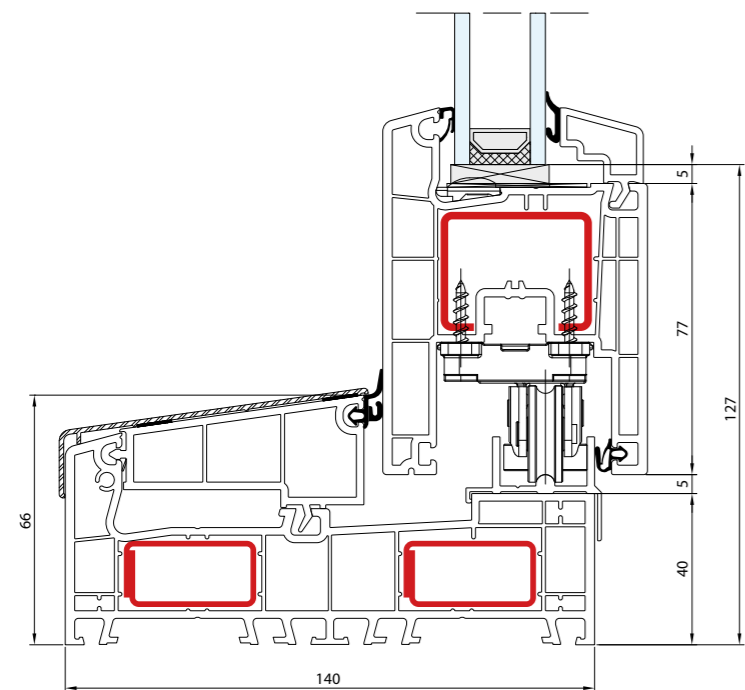
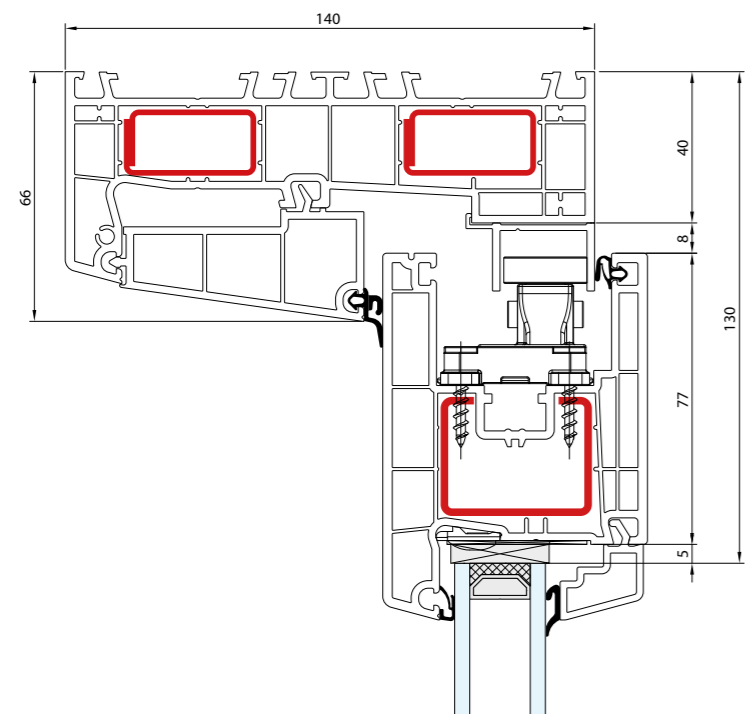

- Schemat A - Przekrój pionowy · Rama: 56 mm · Skrzydło: 97 mm
- Schéma A - Coupe verticale · Dormant: 56 mm · Vantail: 97 mm
- Schema A - Doorsnede verticaal · Frame: 56 mm · Sash: 97 mm
- Schema A - Senkrechter Schnitt · Rahmen: 56 mm · Flügel: 97 mm
- Schema A - Sezione verticale · Telaio: 56 mm · Anta: 97 mm

EASY SLIDE

MULTI SLIDE

SMART SLIDE

HST 70

HST 85

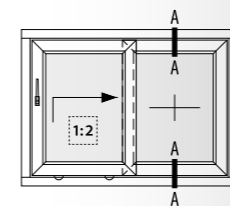
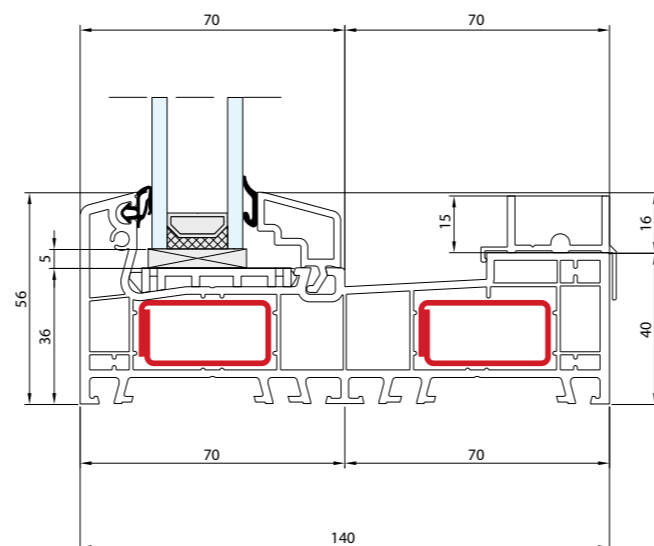
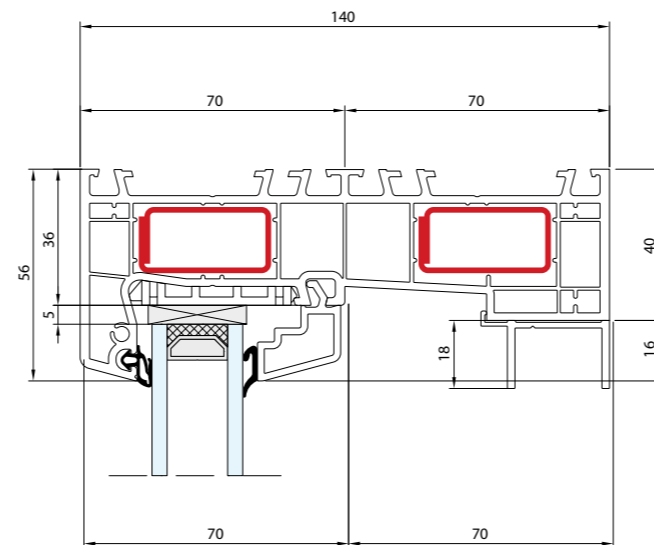

- Schemat A - Przekrój pionowy · Rama: 56 mm · Skrzydło: 97 mm
- Schéma A - Coupe verticale · Dormant: 56 mm · Vantail: 97 mm
- Schema A - Doorsnede verticaal · Frame: 56 mm · Sash: 97 mm
- Schema A - Senkrechter Schnitt · Rahmen: 56 mm · Flügel: 97 mm
- Schema A - Sezione verticale · Telaio: 56 mm · Anta: 97 mm

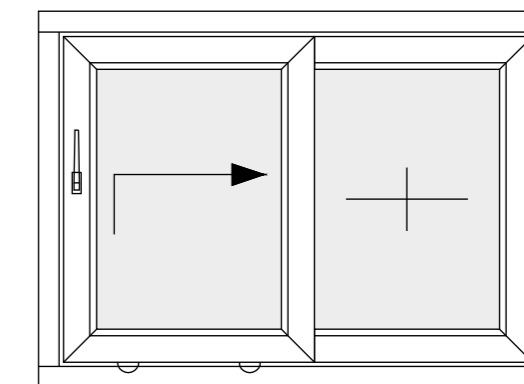

A

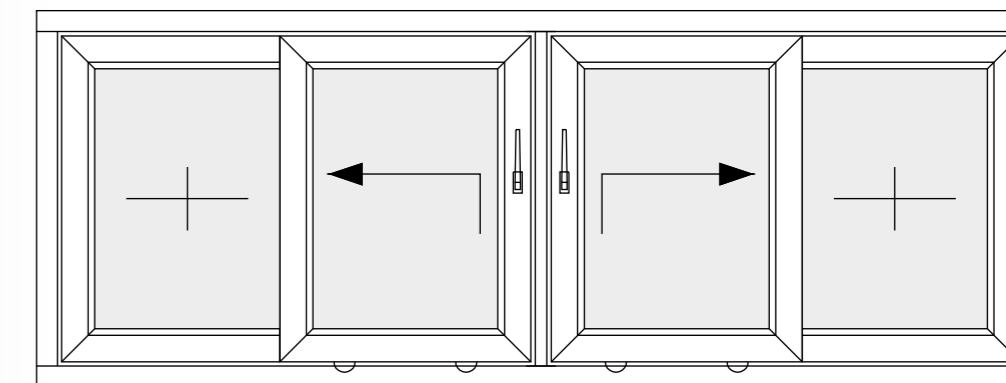

C

- Schemat
- Schéma
- Schema
- Schema
- Schema

EASY SLIDE

MULTI SLIDE

SMART SLIDE

HST 70

HST 85

HST 70

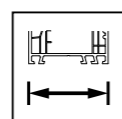

167

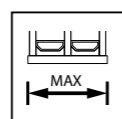

42

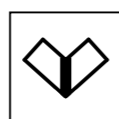

SUPER SOLUTION



EASY SLIDE

MULTI SLIDE

SMART SLIDE

HST 70

HST 85

EASY SLIDE

MULTI SLIDE

SMART SLIDE

HST 70

HST 85

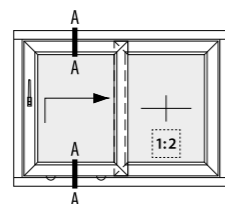
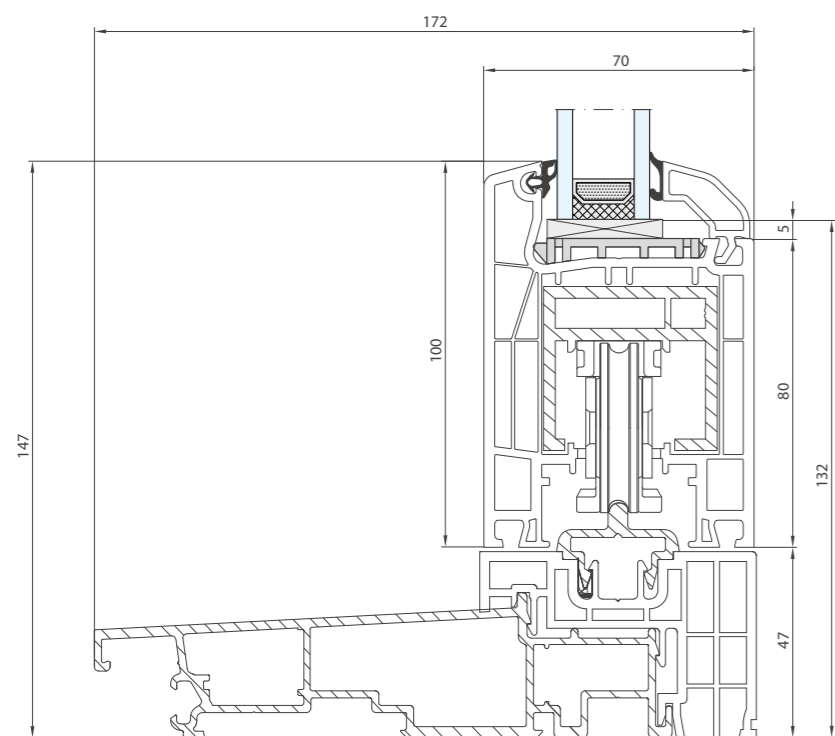
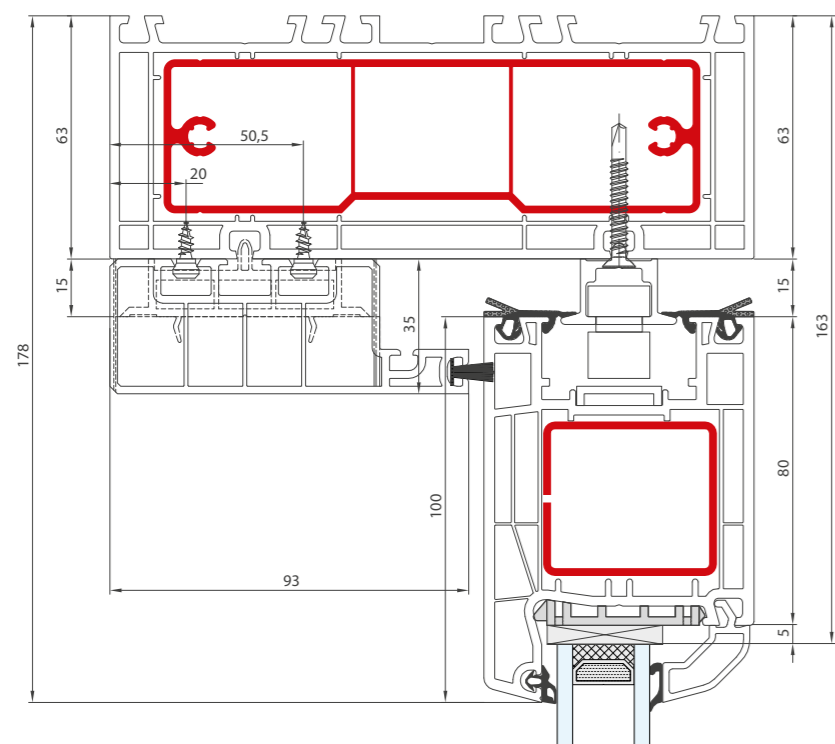

- Schemat A - Przekrój pionowy · Próg: 47 mm · Skrzydło: 100 mm
- Schéma A - Coupe verticale · Seuil: 47 mm · Vantail: 100 mm
- Schema A - Doorsnede verticaal · Doorstep: 47 mm · Sash: 100 mm
- Schema A - Senkrechter Schnitt · Schwelle: 47 mm · Flügel: 100 mm
- Schema A - Sezione verticale · Soglia: 47 mm · Anta: 100 mm

EASY SLIDE

MULTI SLIDE

SMART SLIDE

HST 70

HST 85

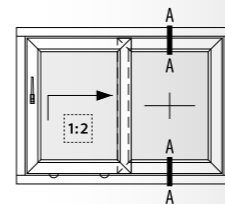
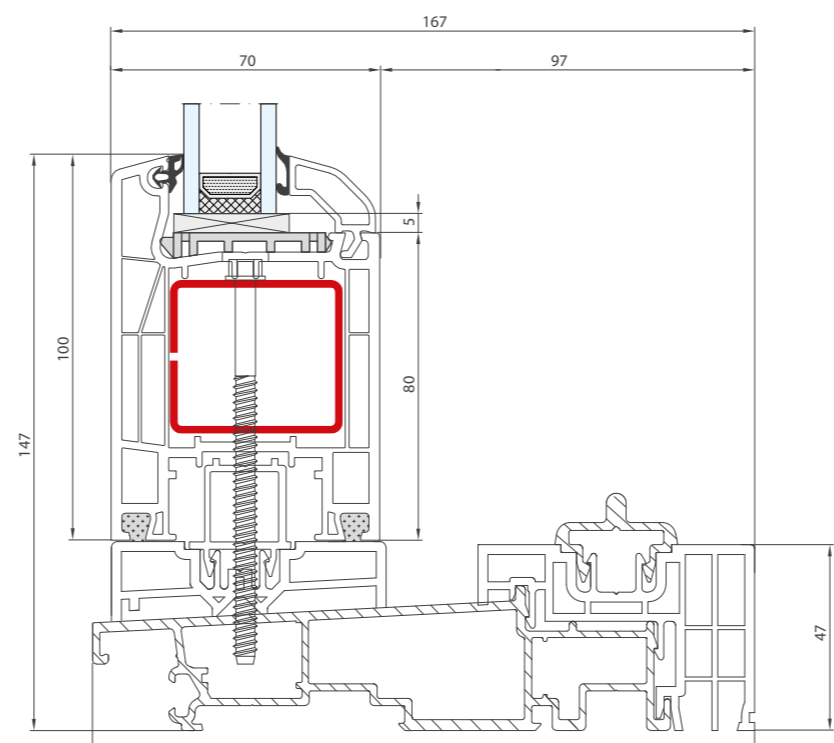
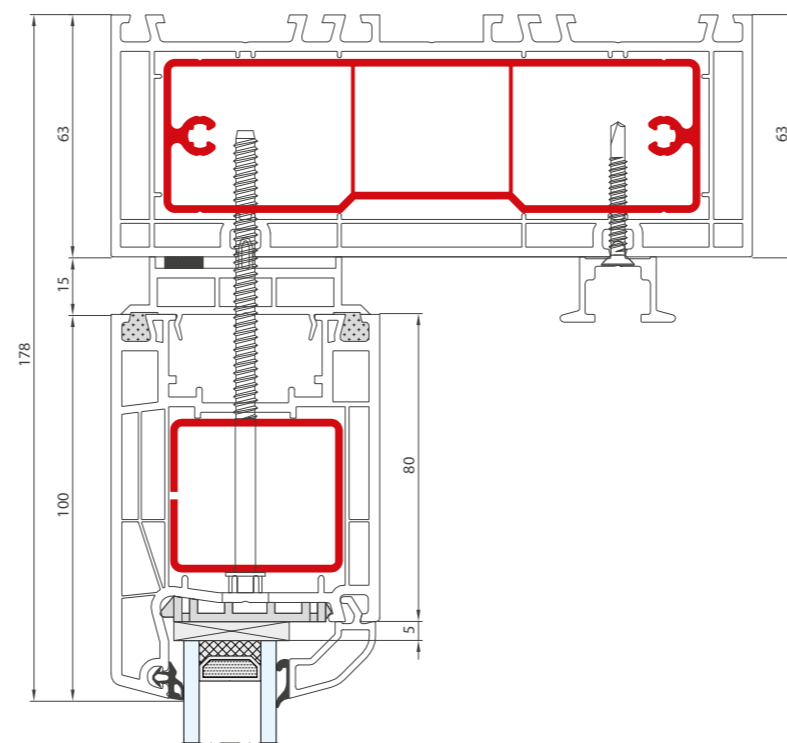

- Schemat A - Przekrój pionowy · Próg: 47 mm · Skrzydło: 100 mm
- Schéma A - Coupe verticale · Seuil: 47 mm · Vantail: 100 mm
- Schema A - Doorsnede verticaal · Doorstep: 47 mm · Sash: 100 mm
- Schema A - Senkrechter Schnitt · Schwelle: 47 mm · Flügel: 100 mm
- Schema A - Sezione verticale · Soglia: 47 mm · Anta: 100 mm

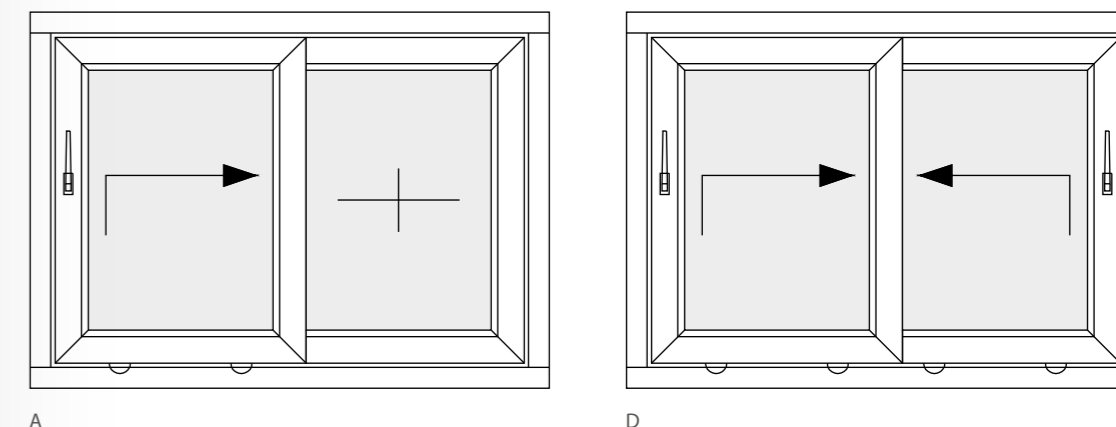

A

D

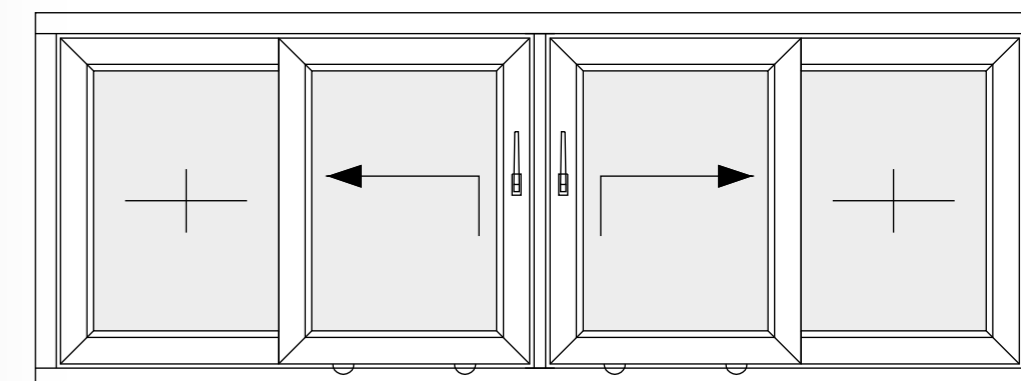

C

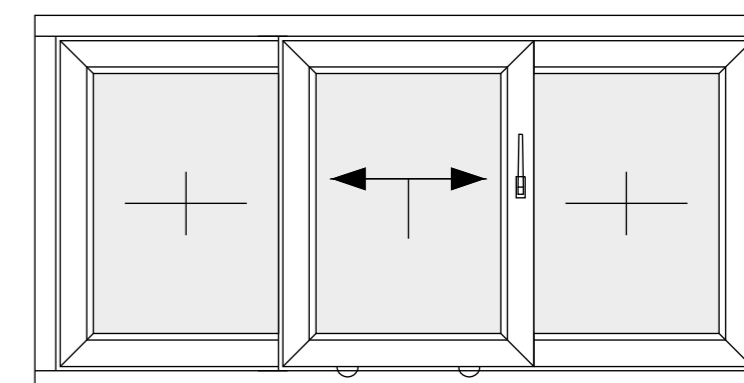

G

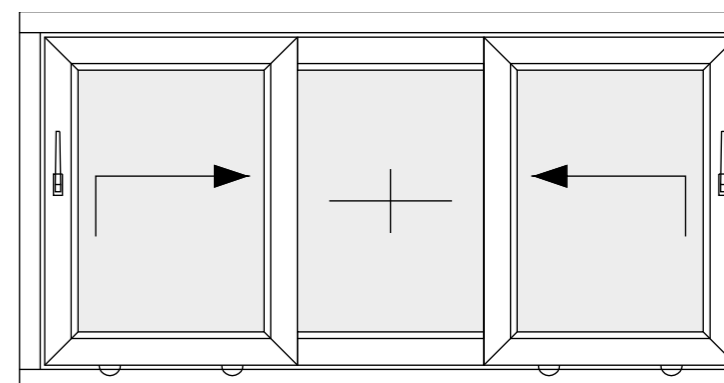

K

- Schemat
- Schéma
- Schema
- Schema
- Schema

EASY SLIDE

MULTI SLIDE

SMART SLIDE

HST 70

HST 85

HST 85

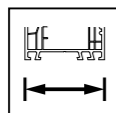
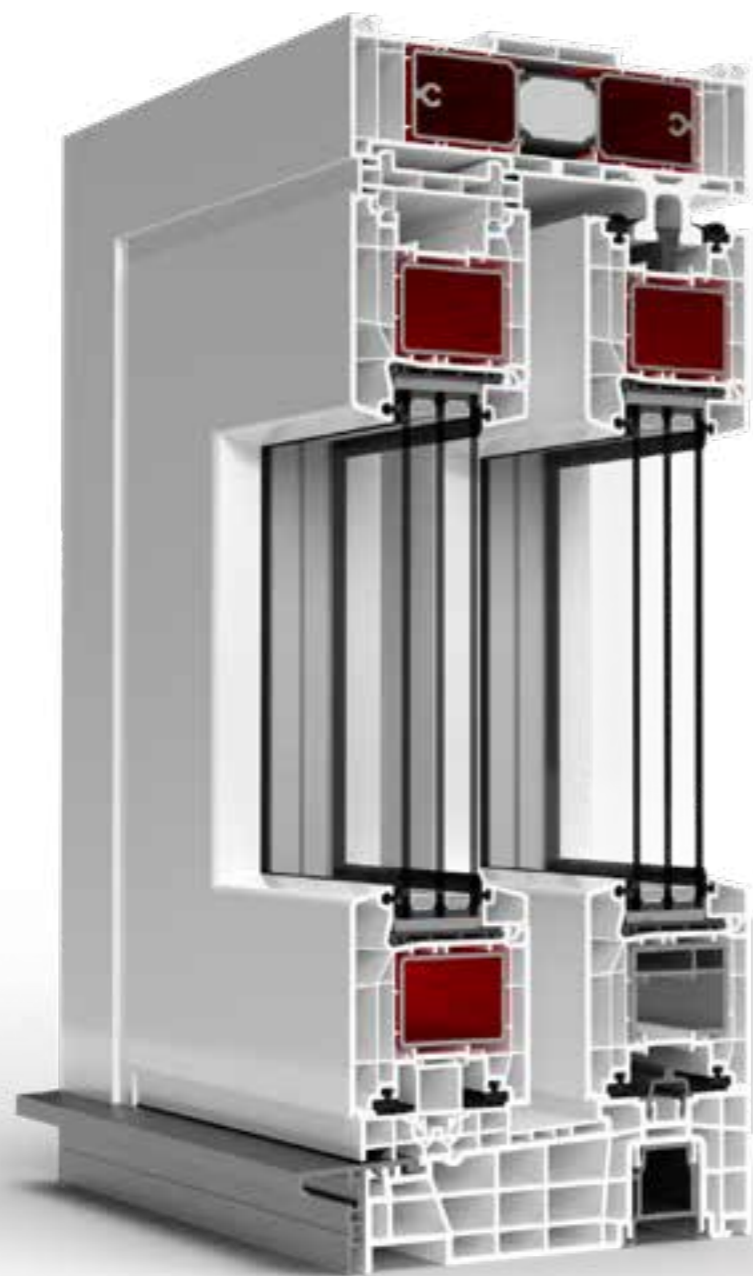

197

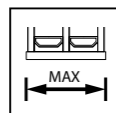

52

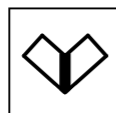

SUPER SOLUTION



ALU

EASY SLIDE

MULTI SLIDE

SMART SLIDE

HST 70

HST 85 +



EASY SLIDE

MULTI SLIDE

SMART SLIDE

HST 70

HST 85 +

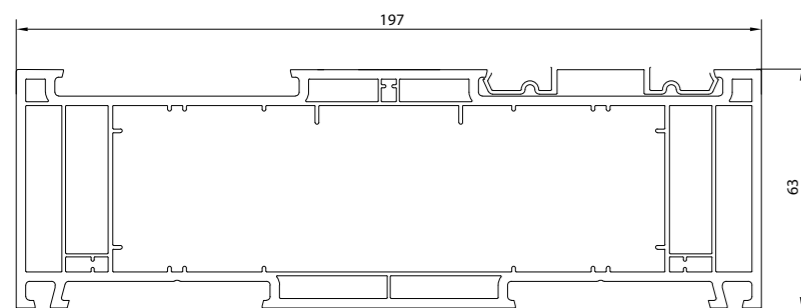

CL ALU 170x80

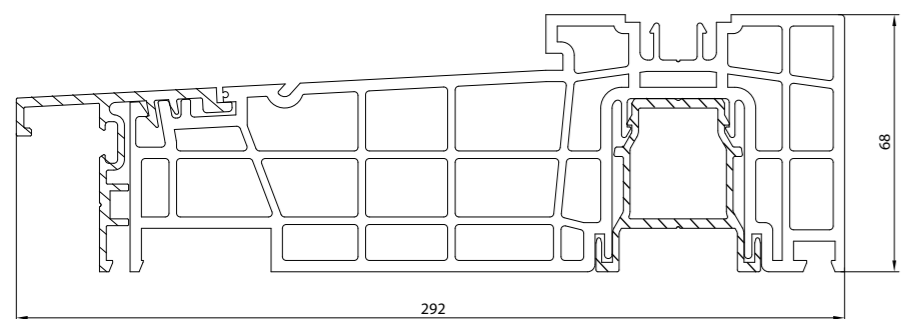

ThermoStep

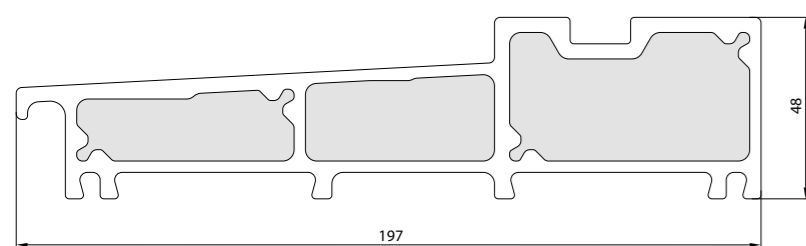

Premium

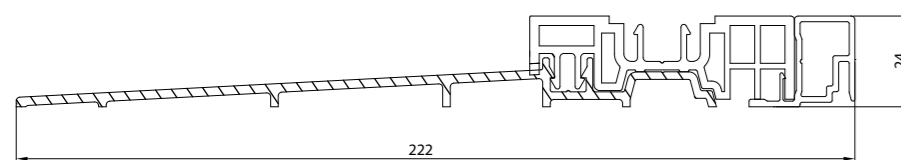

Flatstep

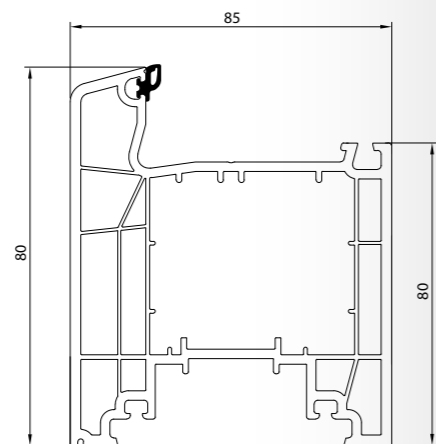



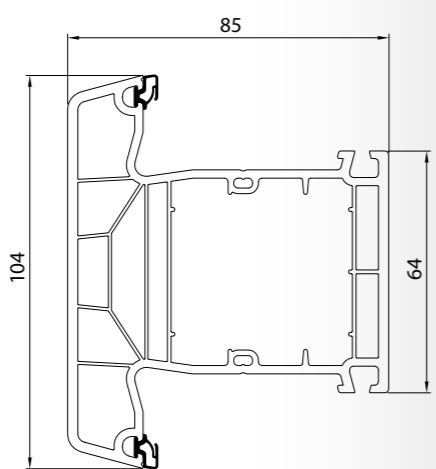

CL ALU 170x81

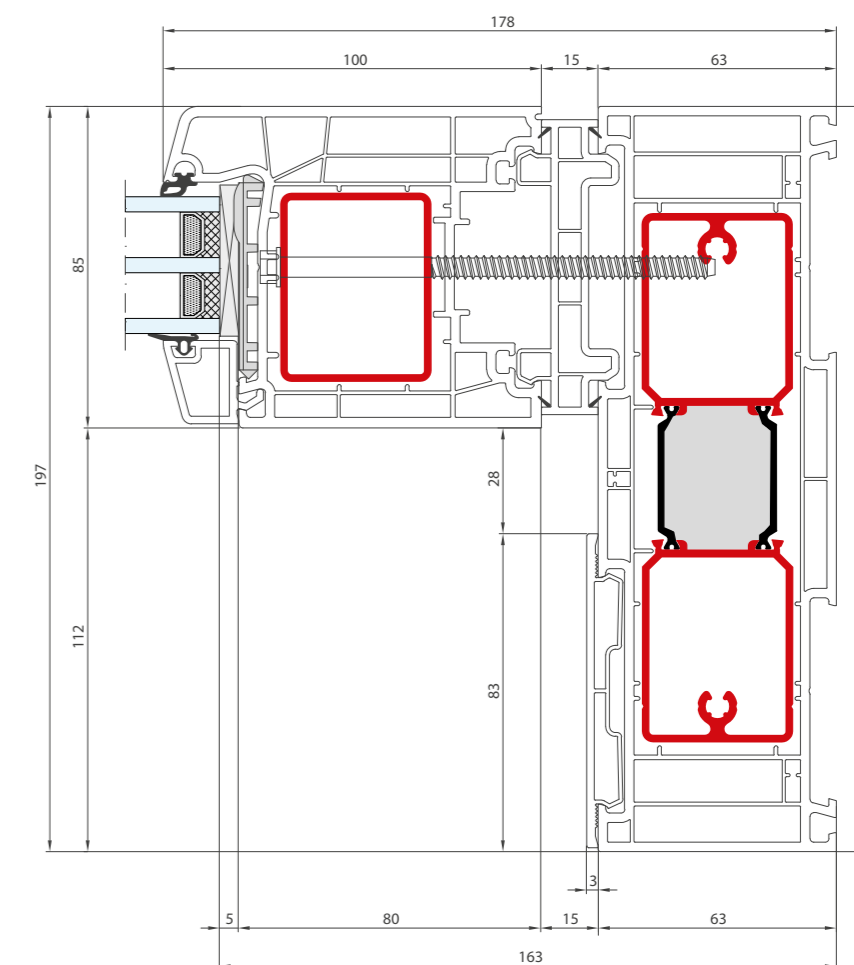
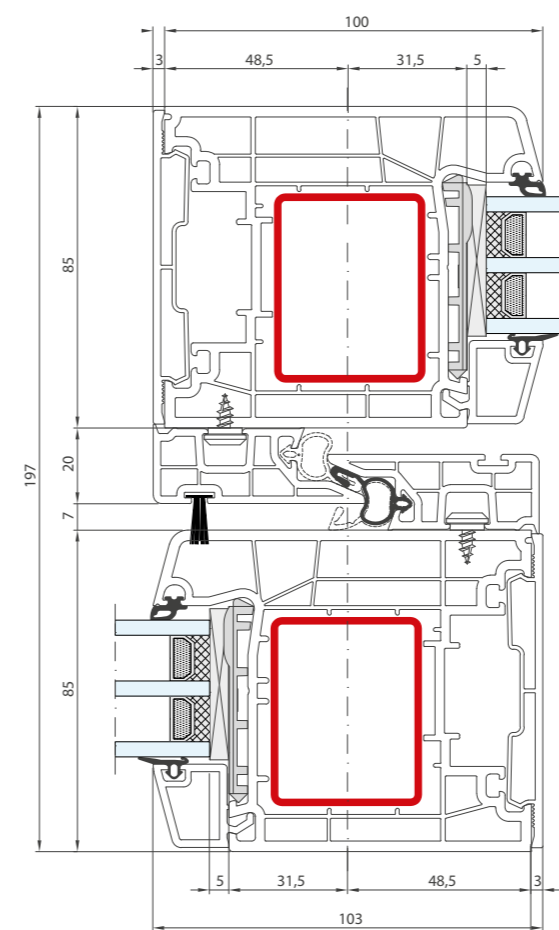
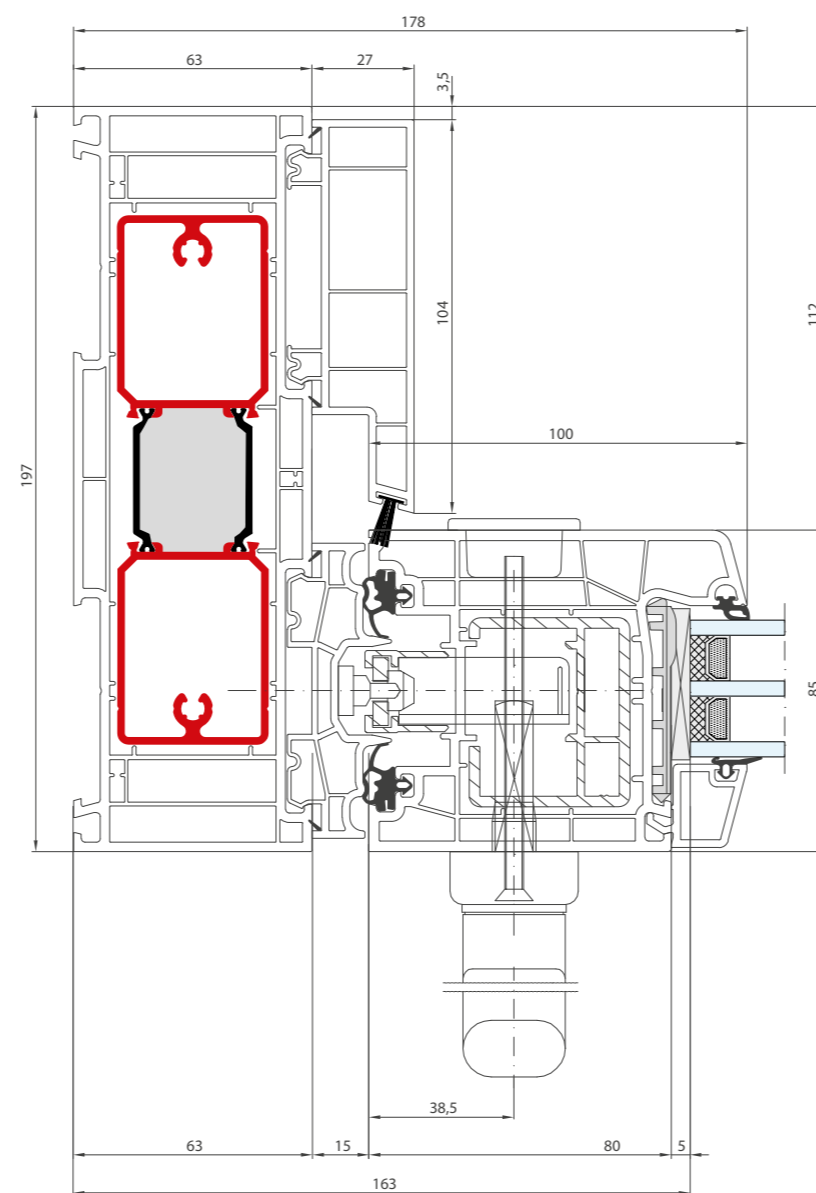

CL ALU 170x44



-  Schemat A - Przekrój poziomy · Rama: 63 mm · Skrzydło: 100 mm
-  Schéma A - Coupe horizontale · Dormant: 63 mm · Vantail: 100 mm
-  Schema A - Doorsnede horizontaal · Frame: 63 mm · Sash: 100 mm
-  Schema A - Wagerechter Schnitt · Rahmen: 63 mm · Flügel: 100 mm
-  Schema A - Sezione orizzontale · Telaio: 63 mm · Anta: 100 mm

1:2

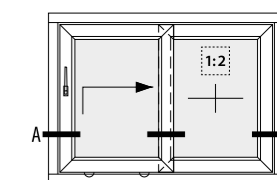

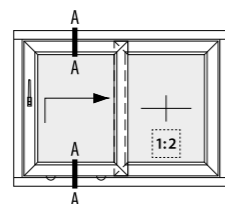
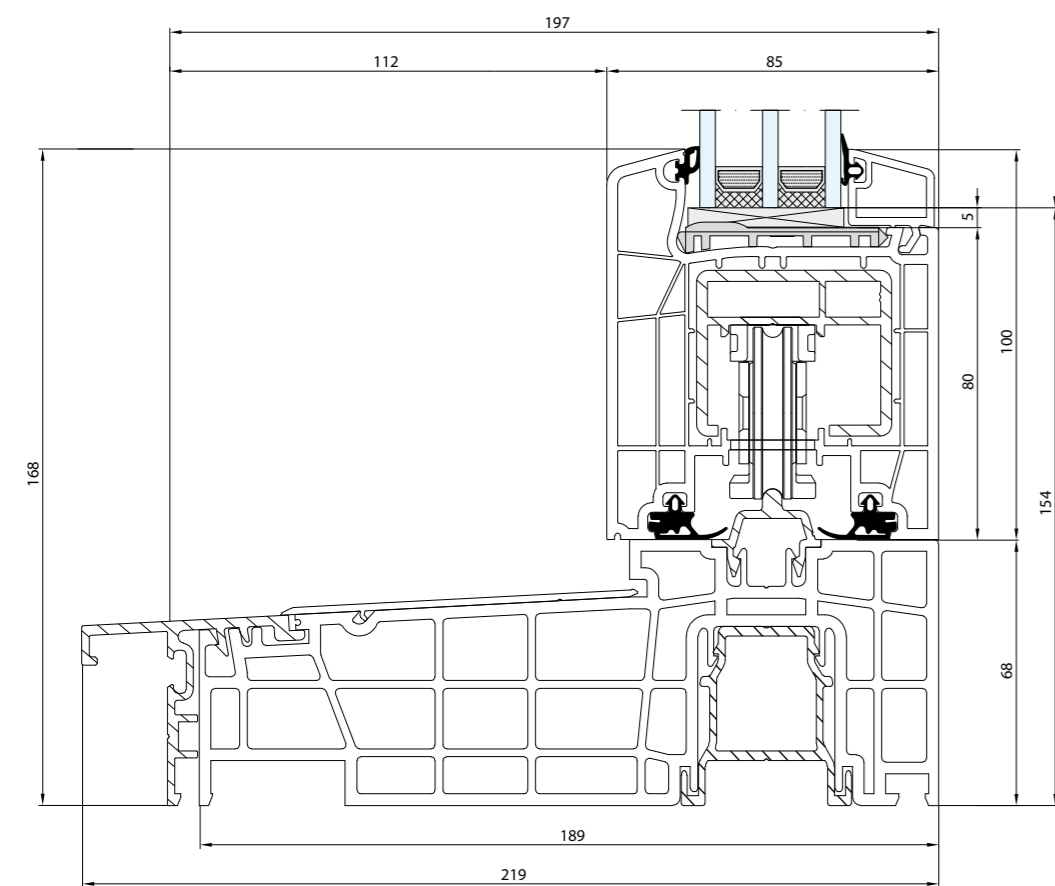
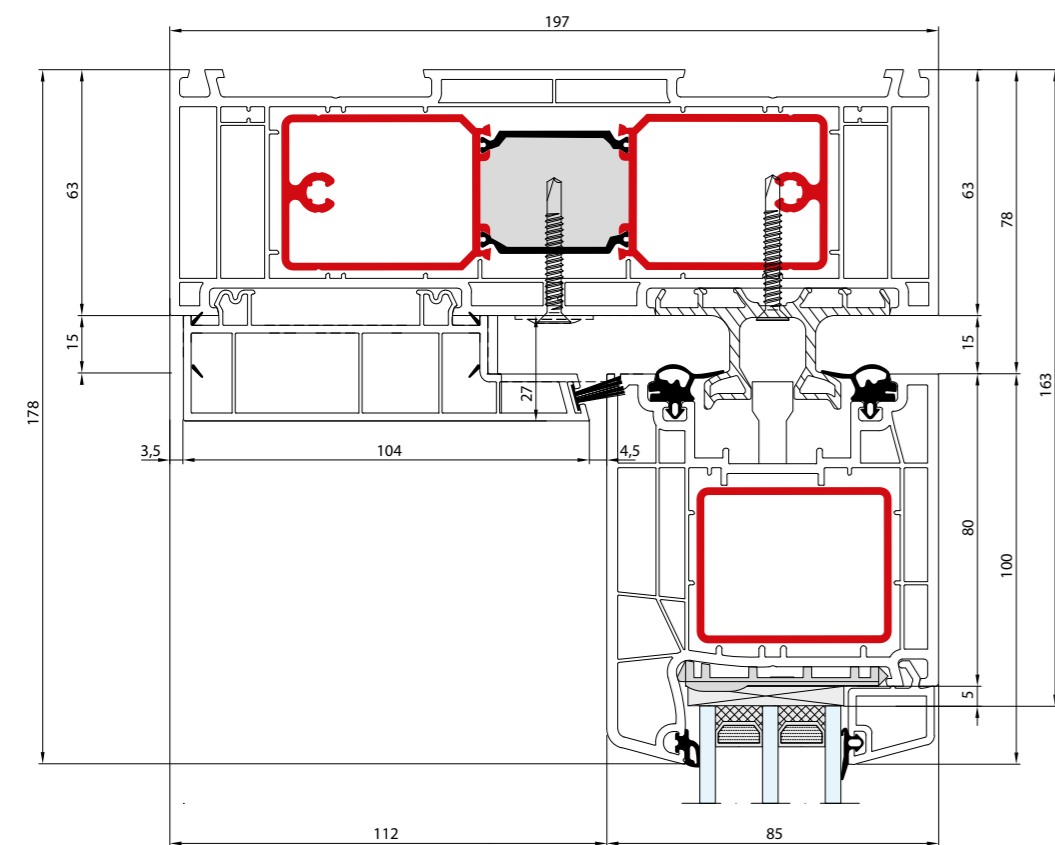

- Schemat A - Przekrój pionowy · Próg: 68 mm · Skrzydło: 100 mm
- Schéma A - Coupe verticale · Seuil: 68 mm · Vantail: 100 mm
- Schema A - Doorsnede verticaal · Doorstep: 68 mm · Sash: 100 mm
- Schema A - Senkrechter Schnitt · Schwelle: 68 mm · Flügel: 100 mm
- Schema A - Sezione verticale · Soglia: 68 mm · Anta: 100 mm

EASY SLIDE

MULTI SLIDE

SMART SLIDE

HST 70

HST 85

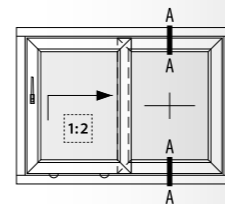
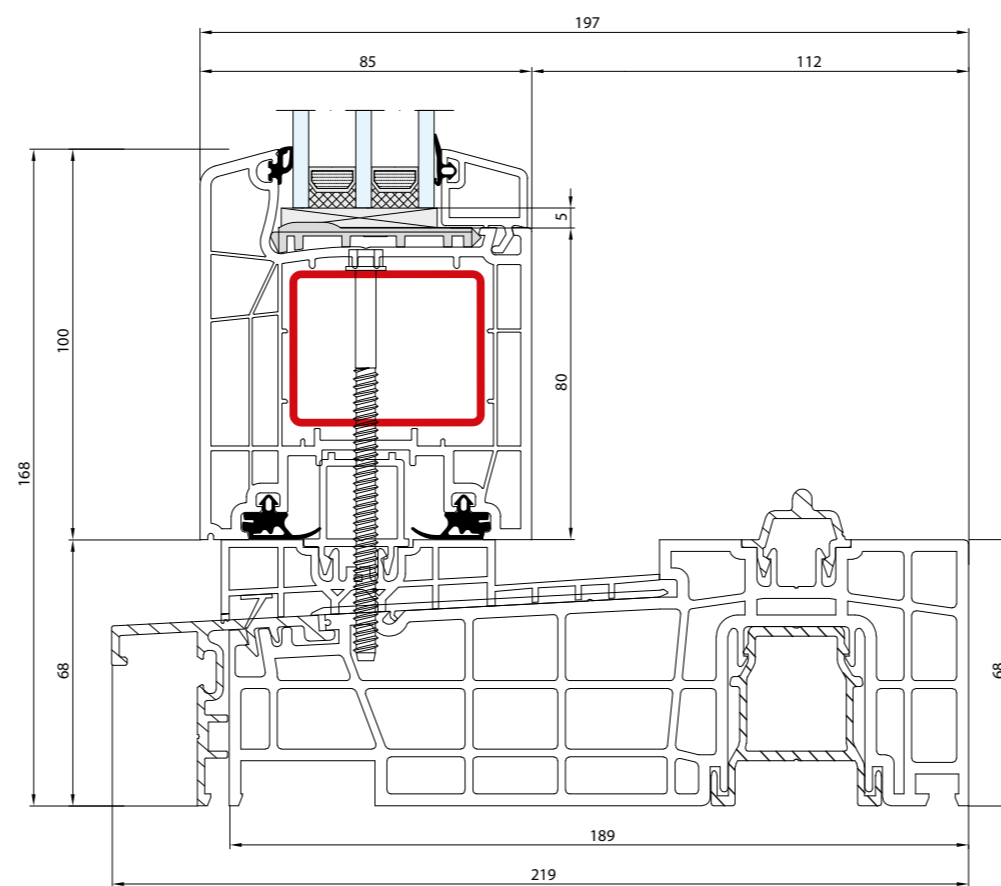
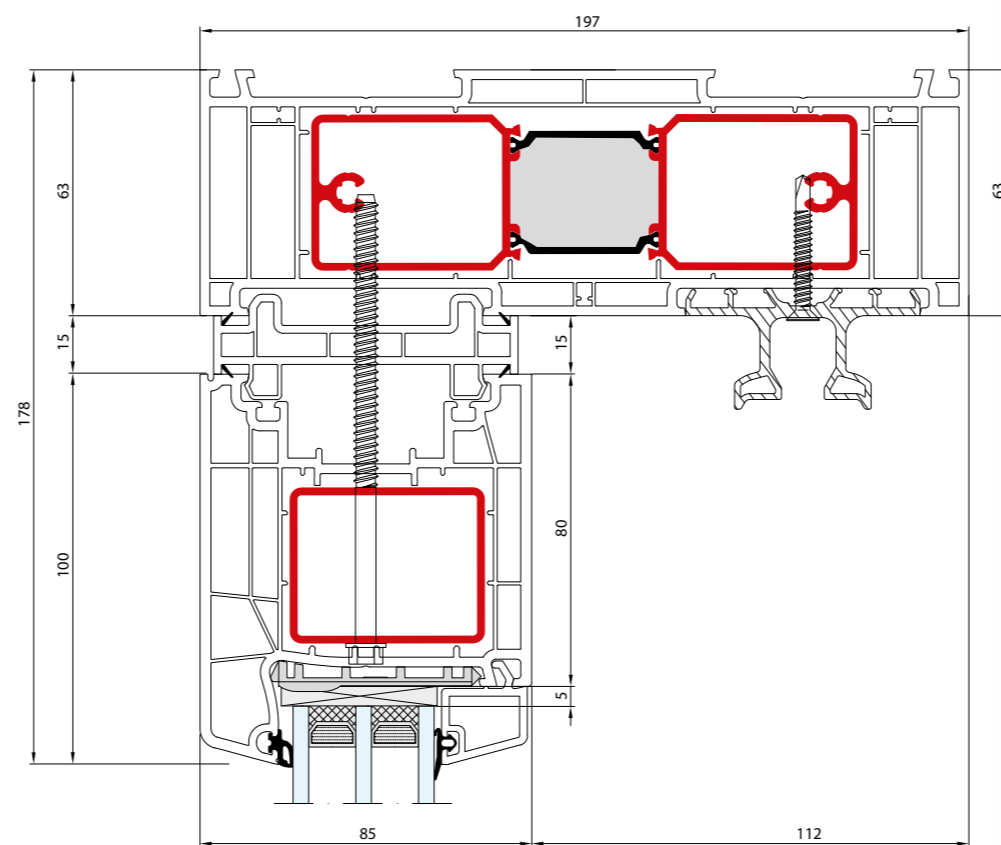

- Schemat A - Przekrój pionowy · Próg: 68 mm · Skrzydło: 100 mm
- Schéma A - Coupe verticale · Seuil: 68 mm · Vantail: 100 mm
- Schema A - Doorsnede verticaal · Doorstep: 68 mm · Sash: 100 mm
- Schema A - Senkrechter Schnitt · Schwelle: 68 mm · Flügel: 100 mm
- Schema A - Sezione verticale · Soglia: 68 mm · Anta: 100 mm



- Schemat
- Schéma
- Schema
- Schema
- Schema

EASY SLIDE

MULTI SLIDE

SMART SLIDE

HST 70

HST 85

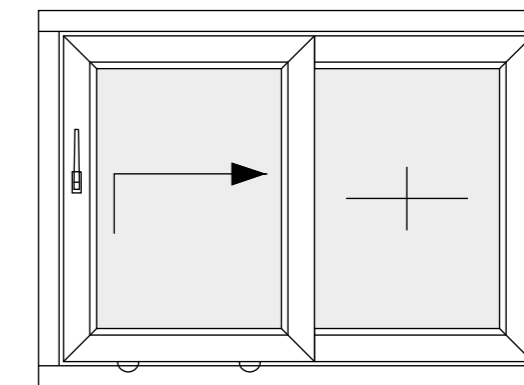



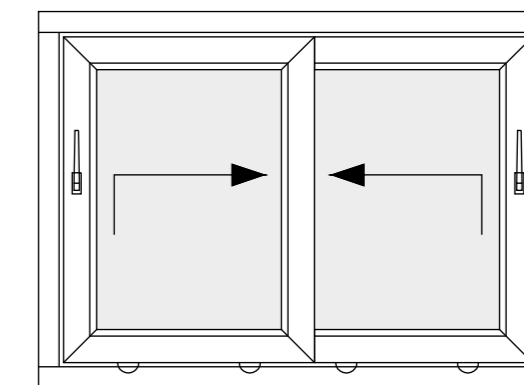

A

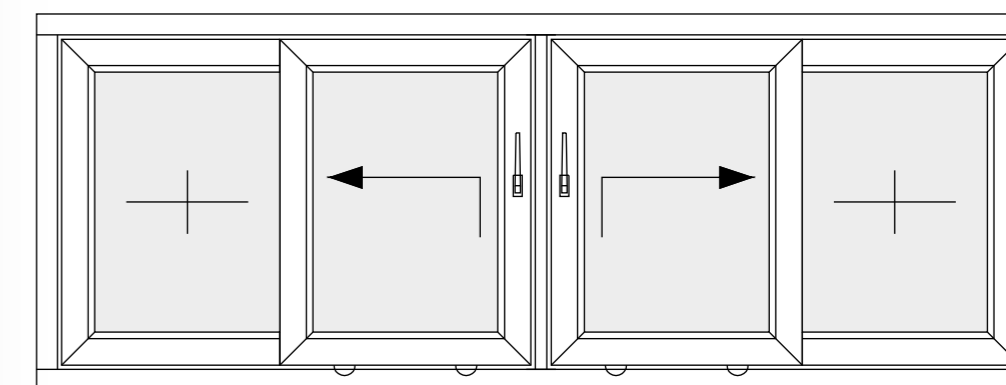

D

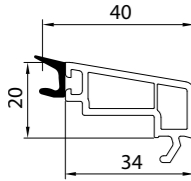
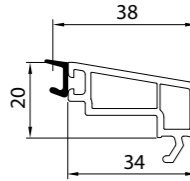
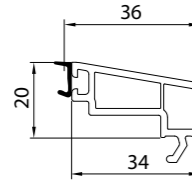
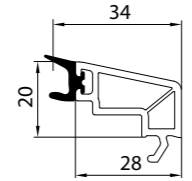
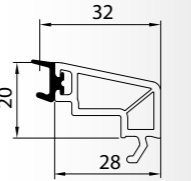

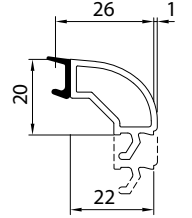
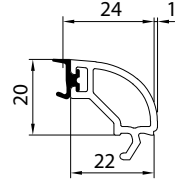
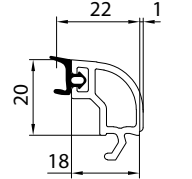
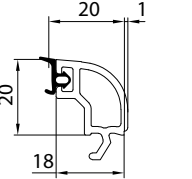
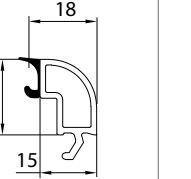
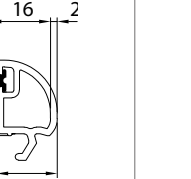
C

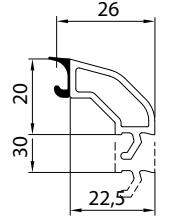
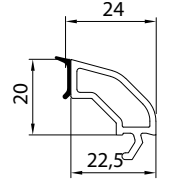
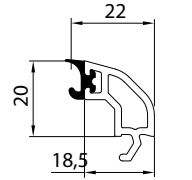
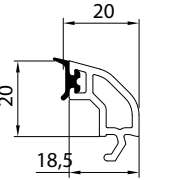
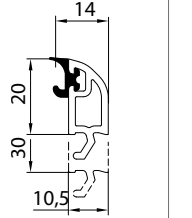
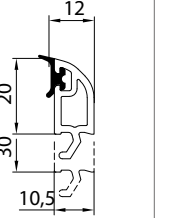
	d [mm]										
Ideal 4000 Ideal 5000 Nord-line (S) Blockprofil Monoblock Nordline Ideal 70/Cas HST 70 Smartslide	10 - 11	12 - 13	14 - 15	16 - 17	18 - 19						
Ideal 7000 Ideal 8000 Energeto 8000 Nord-line (R) HST 85	20 - 21	22 - 23	24 - 25	26 - 27	28 - 29						
Ideal 4000 > 140x27	17 - 18	19 - 20	21 - 22	23 - 24	25 - 26						
	 ■ 120740 □ 120770	 ■ 120840 □ 120870	 ■ 120640 □ 120670	 ■ 120738 □ 120768	 ■ 120838 □ 120868						
				 ■ 120850 □ 120880 ■ 130850 □ 130880	 ■ 120650 □ 120680	 ■ 120859 □ 120889	 ■ 120659 □ 120689	 ■ 140852 □ 140882	 ■ 120642 □ 120672		
				 ■ 120846 □ 120876 ■ 130856 □ 130886	 ■ 120646 □ 120676	 ■ 120847 □ 120877	 ■ 120647 □ 120677		 ■ 120849 □ 120879 ■ 130859 □ 130889	 ■ 120649 □ 120679 ■ 130659 □ 130689	

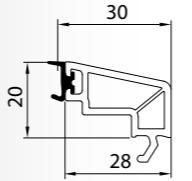
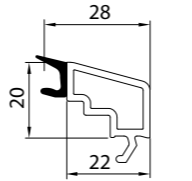
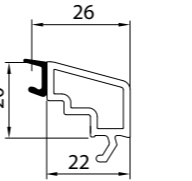
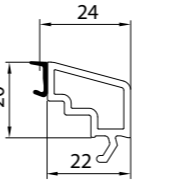
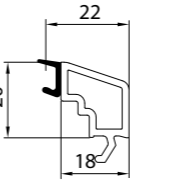
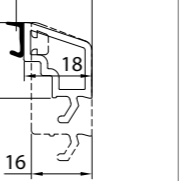
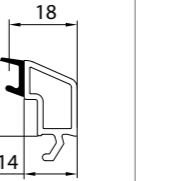
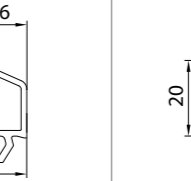
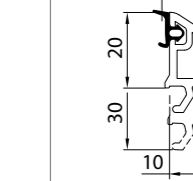
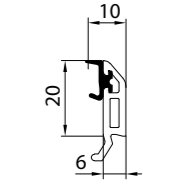
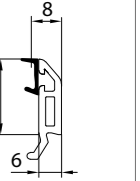
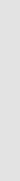
d [mm]												
20 - 21	22 - 23	24 - 25	26 - 27	28 - 29	30 - 31	32 - 33	34 - 35	36 - 37	38 - 39	40 - 41	42 - 43	
30 - 31	32 - 33	34 - 35	36 - 37	38 - 39	40 - 41	42 - 43	44 - 45	46 - 47	48 - 49	50 - 51	52 - 53	
27 - 28	29 - 30	31 - 32	33 - 34	35 - 36	37 - 38	39 - 40	41 - 42	43 - 44	45 - 46	47 - 48		
 ■ 120638 □ 120668	 ■ 120736 □ 120766	 ■ 120836 □ 120866	 ■ 120636 □ 120666	 ■ 120835 □ 120865	 ■ 120635 □ 120665 ■ 130854 □ 130884	 ■ 120833 □ 120863	 ■ 120633 □ 120663	 ■ 120832 □ 120862	 ■ 120632 □ 120662 ■ 130653 □ 130683	 ■ 140831 □ 140861	 ■ 140631 □ 140661	

		d [mm]									
Easy Slide					30 - 31	32 - 33	34 - 35	36 - 37	38 - 39	40 - 41	
Multi Slide		6 - 7	8 - 9	10 - 11	12 - 13	14 - 15	16 - 17	18 - 19	20 - 21	22 - 23	
CL											
		120640 120670	120738 120768	120838 120868	120638 120668	120736 120766	120836 120866	120636 120666	120835 120865	120635 120665	
RL											
							120850 120880	120650 120680	120859 120889	120659 120689	
SL											
							120846 120876	120646 120676	120847 120877	120647 120677	

d [mm]					
42 - 43	44 - 45	46 - 47	48 - 49	50 - 51	52 - 53
24 - 25	26 - 27	28 - 29	30 - 31	32 - 33	34 - 35
120833 120863	120633 120663	120832 120862	120632 120662	140831 140861	140631 140661
140852 140882	120642 120672				
		120849 120879	120649 120679		

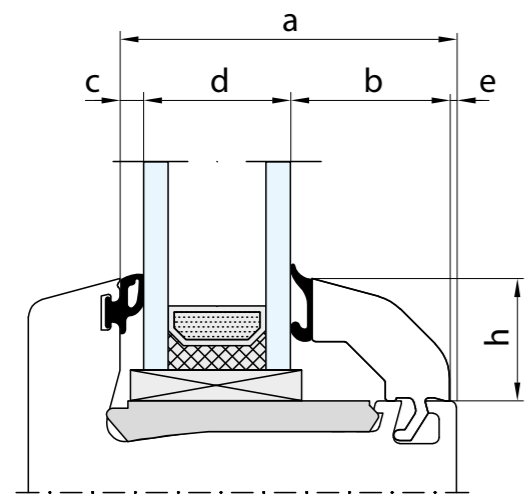

$b = a - c - d - e$

	a [mm]	c [mm]	e [mm]
Ideal 4000	55	4	1
> 140x27	63	4	1
Ideal 5000 Nordline ** Blockprofil Monoblock Ideal 70/Cas HST 70 Smart-Slide	55	4	1
Ideal 7000 Ideal 8000 Energeto 8000 Nordline * HST 85	65	4	1
Easy Slide	32	4	1
Multi Slide	47	4	1

- * Rama
- Dormant
- Frame
- Rahmen
- Telaio
- ** Skrzydło
- Vantail
- Sash
- Flügel
- Anta

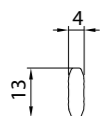

120116

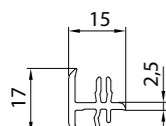

120224

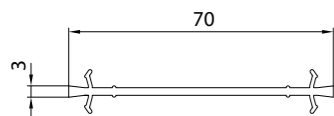

140203

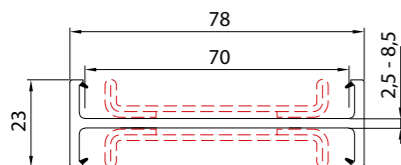

140267

-	0,0	-	lx 0,0	ly 0,0
	1,5	209900	lx 0,1	ly 7,3
	1,5	209900 x 2	lx 0,2	ly 14,6

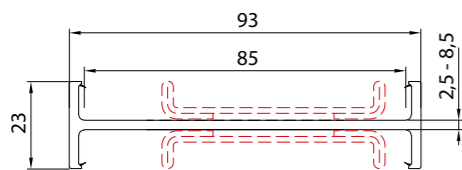

180267

-	0,0	-	lx 0,0	ly 0,0
	1,5	209900	lx 0,1	ly 7,3
	1,5	209900 x 2	lx 0,2	ly 14,6

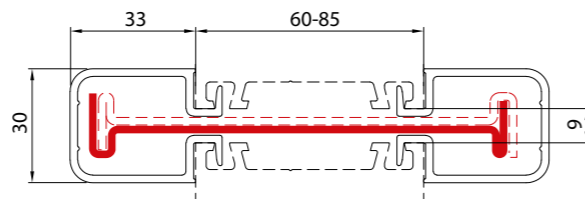

120219

	2,0	229019	lx 0,2	ly 43,3
	2,0	229019 x 2	lx 0,4	ly 86,6

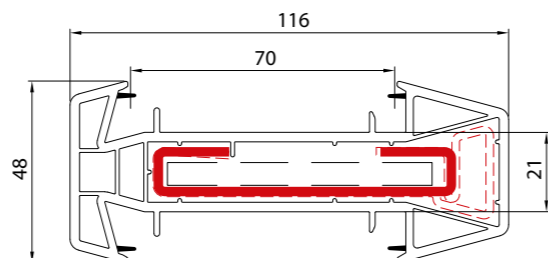

140218

	2,5	229018	lx 0,7	ly 24,8
	2,5+6,0	229018 + 6x70	lx 0,8	ly 41,9
	2,0	289218	lx 1,3	ly 36,9
	2,0+6,0	289218 + 6x70	lx 1,5	ly 54,1

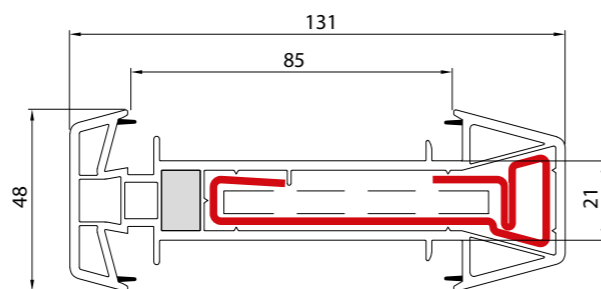

180218

	2,0	289218	lx 1,3	ly 36,9
	2,0+6,0	289218 + 6x70	lx 1,5	ly 54,1

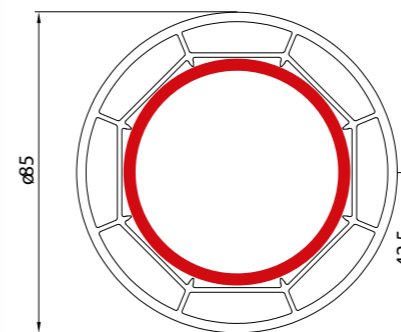

140244

	3,2	249244	lx 23,1	ly 23,1
--	-----	--------	---------	---------

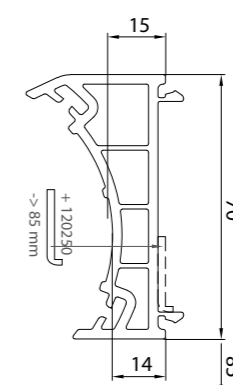

140243

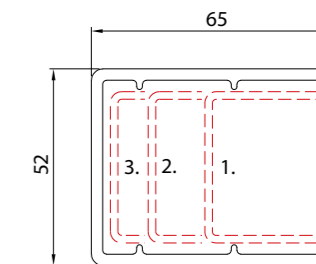

120109

	1,5	229114	lx 4,9	ly 3,9
	2,0	229125	lx 8,5	ly 12,0
	2,0	259926	lx 9,9	ly 18,7

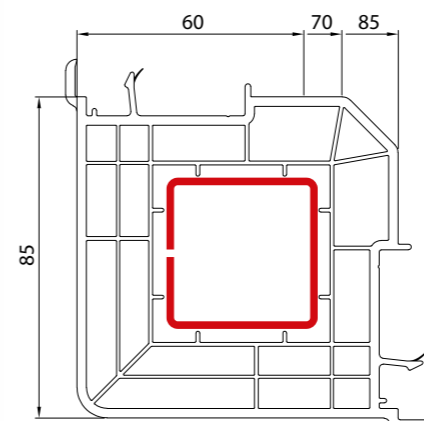

140248

	2,0	229040	lx 7,0	ly 6,9
--	-----	--------	--------	--------

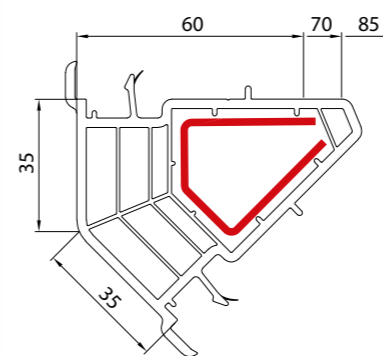

140249

	2,0	249242	lx 2,1	ly 2,8
--	-----	--------	--------	--------

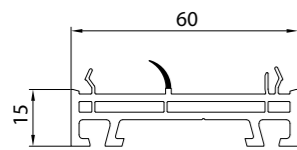

120220

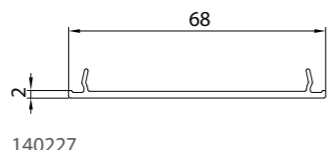

140227

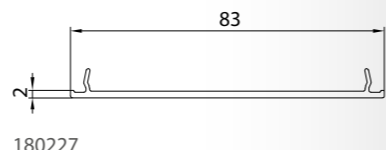

180227

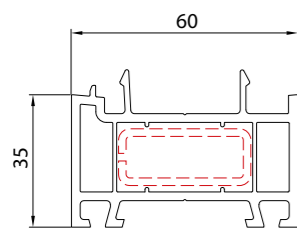

120242

-	0,0	-	lx 0,0	ly 0,0
□	1,5	229110	lx 0,4	ly 1,8

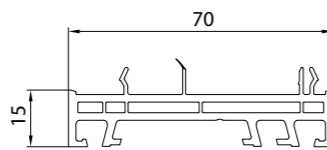

140209

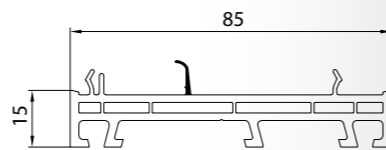

180209

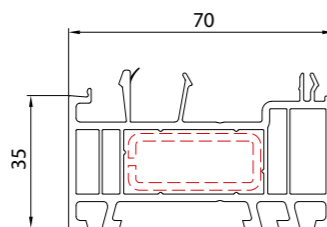

ALU 140205

-	0,0	-	lx 0,0	ly 0,0
□	1,5	229110	lx 0,4	ly 1,8

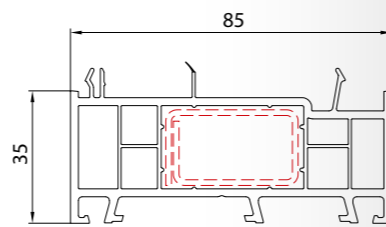

ALU 180201

-	0,0	-	lx 0,0	ly 0,0
□	1,5	229101	lx 1,0	ly 2,8

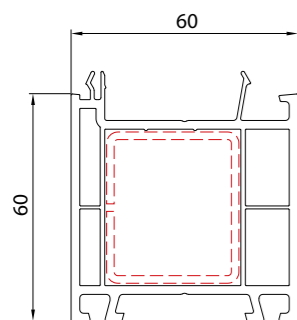

120221

-	0,0	-	lx 0,0	ly 0,0
□	1,5	229114	lx 4,9	ly 3,9

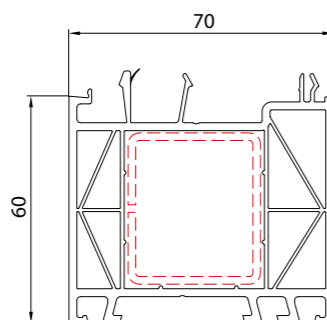

ALU 140207

-	0,0	-	lx 0,0	ly 0,0
□	1,5	229114	lx 4,9	ly 3,9

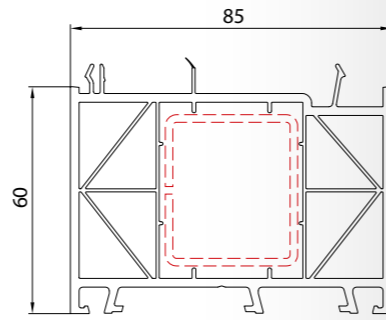

ALU 180203

-	0,0	-	lx 0,0	ly 0,0
□	1,5	229114	lx 4,9	ly 3,9

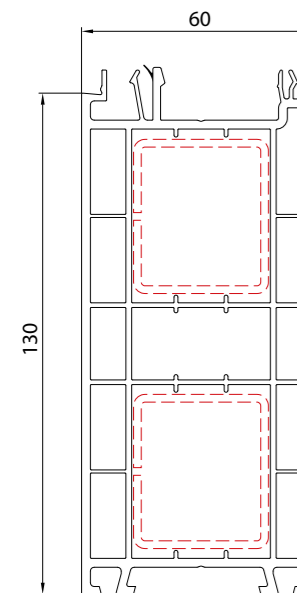

120223

-	0,0	-	lx 0,0	ly 0,0
□	1,5	229114 x 2	lx 9,8	ly 7,8

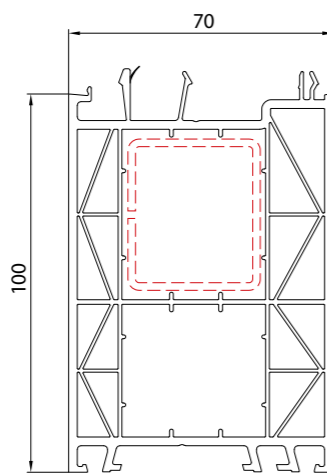

ALU 140208

-	0,0	-	lx 0,0	ly 0,0
□	1,5	229114	lx 4,9	ly 3,9

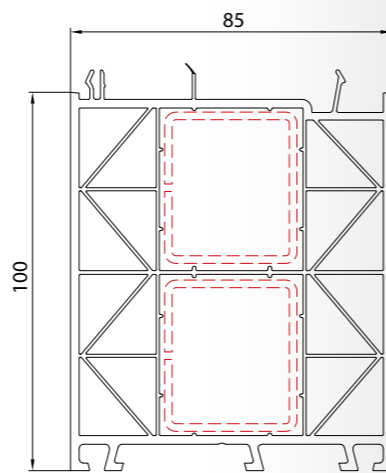

ALU 180204

-	0,0	-	lx 0,0	ly 0,0
□	1,5	229114 x 2	lx 9,8	ly 7,8

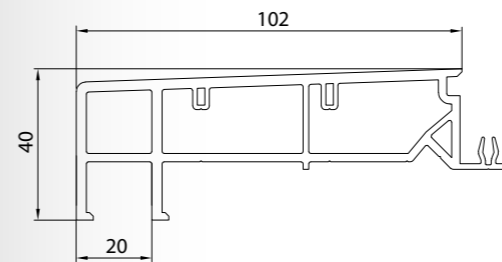

120196

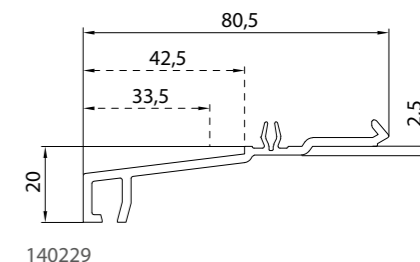

140229

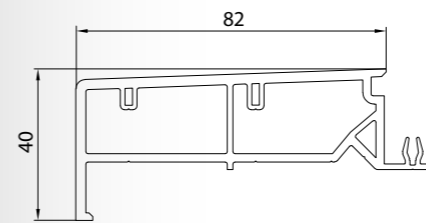

120270

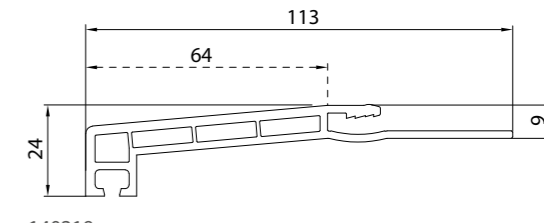

140219

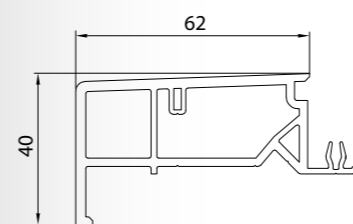

120195

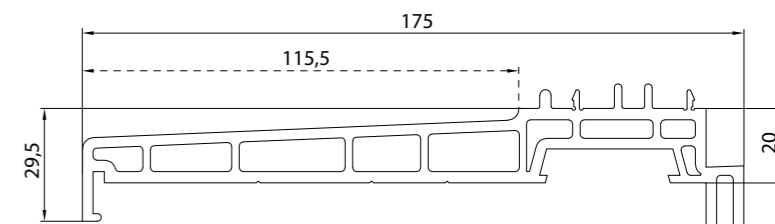

120190

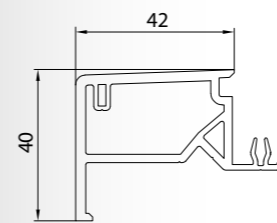

120194

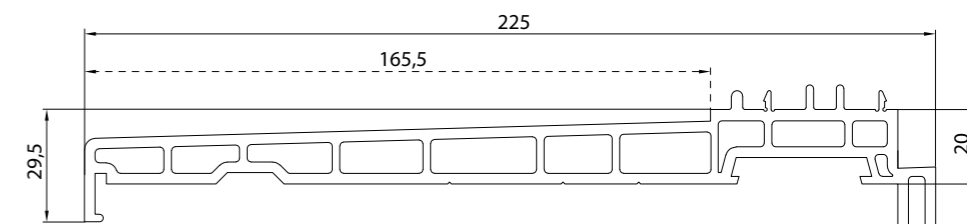

120192

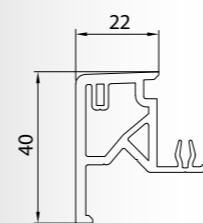

120193

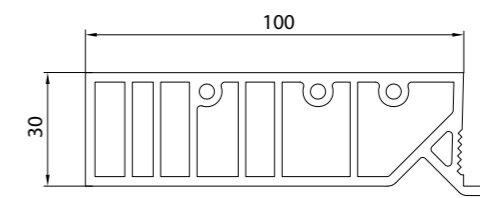

120112

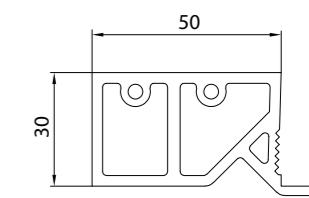

120113

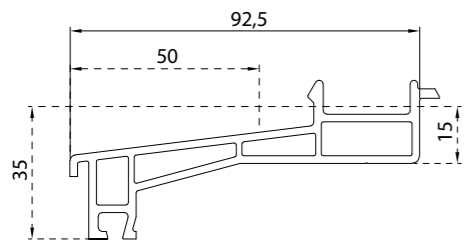

120246

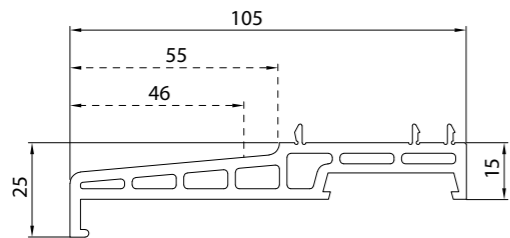

120248

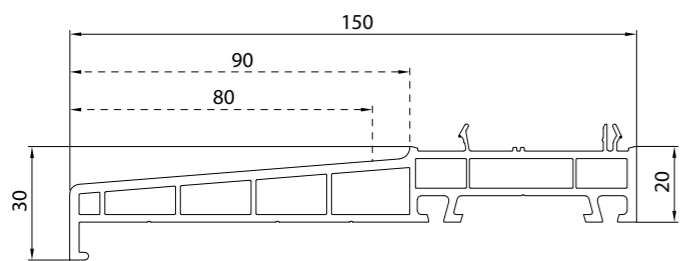

120249

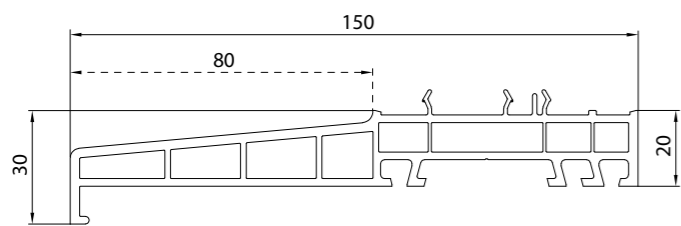

140238

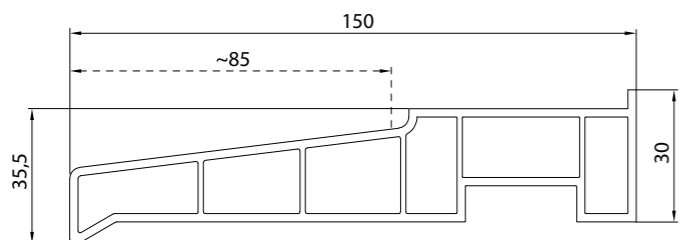

100220

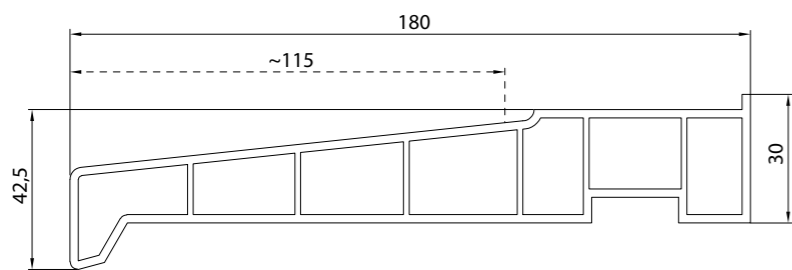

120108

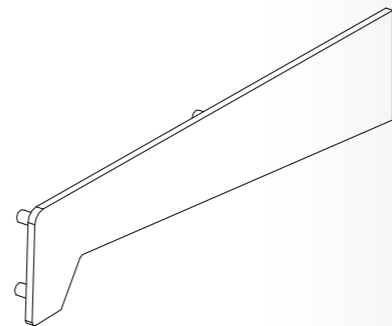

600020

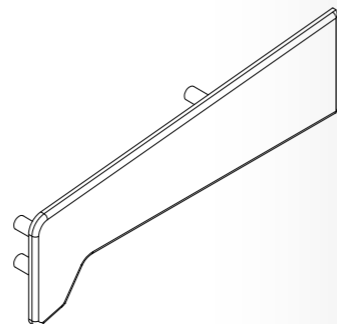

600220

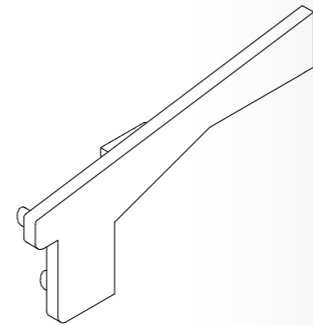

650921

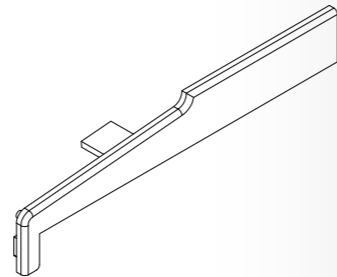

620249

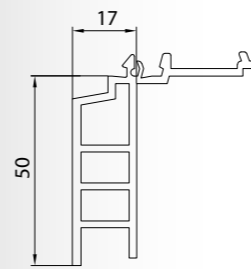

120210

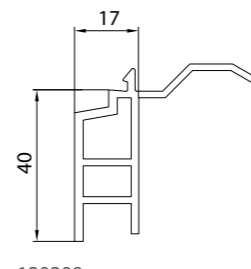

120209

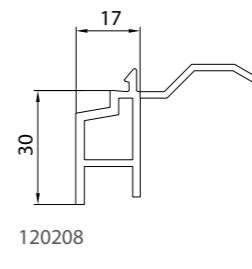

120208

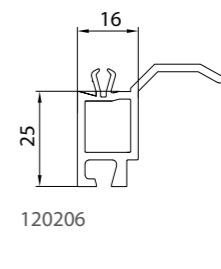

120206

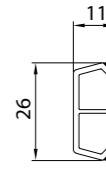

160376

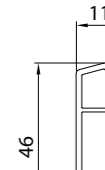

160378

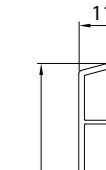

160479

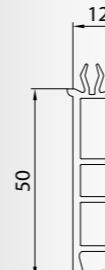

120102

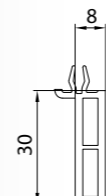

120237

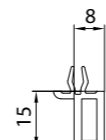

120236

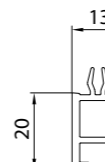

120106

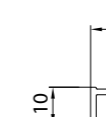

140277

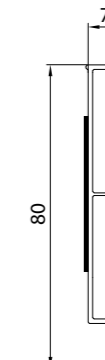

650780

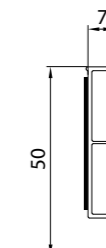

640756

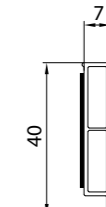

640746

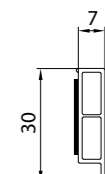

640736

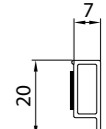

640726

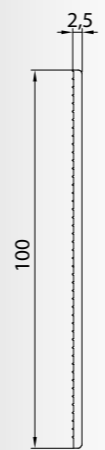

65025100

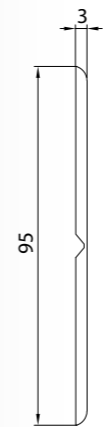

6465050

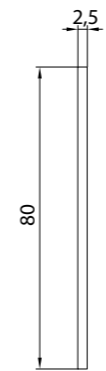

65025080



65025070

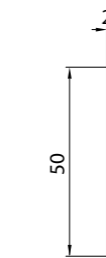

65025050

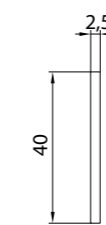

65025040

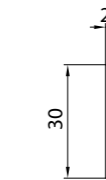

65025030

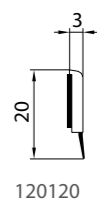

120120

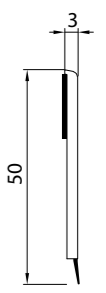

120283

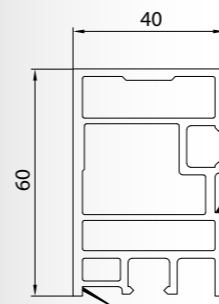

140276

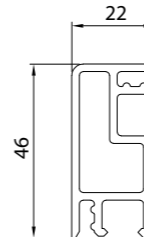

140275

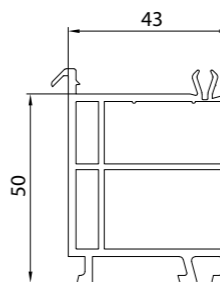

120238

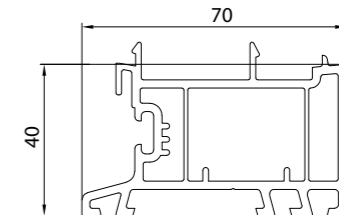

140200

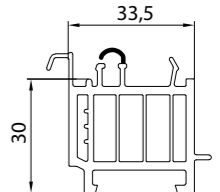

144247

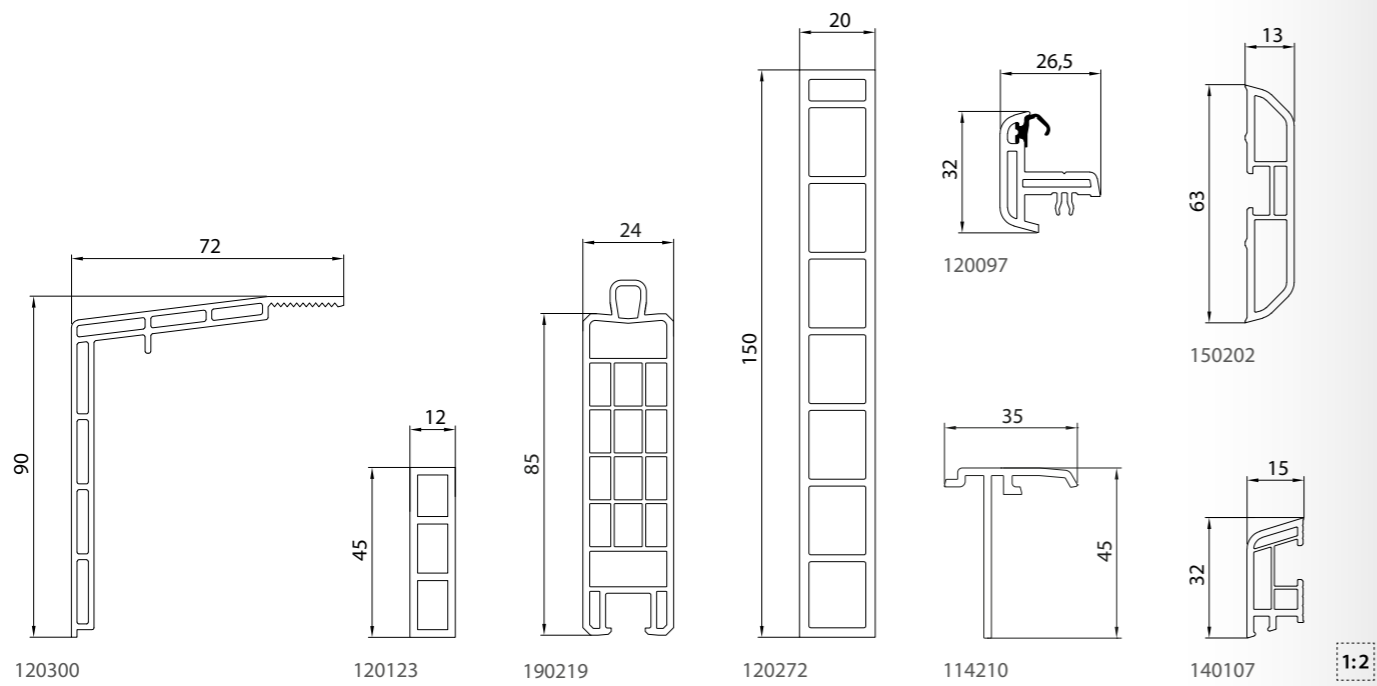
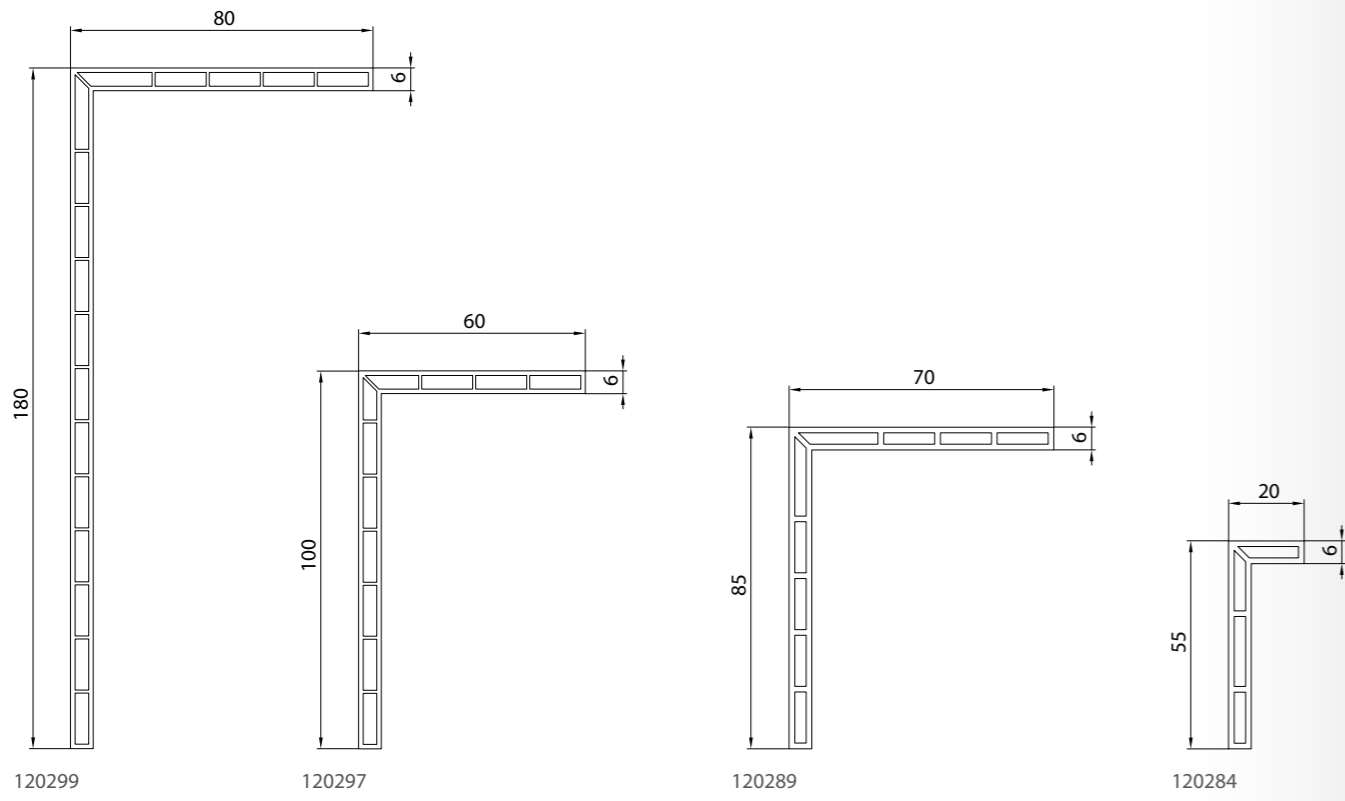
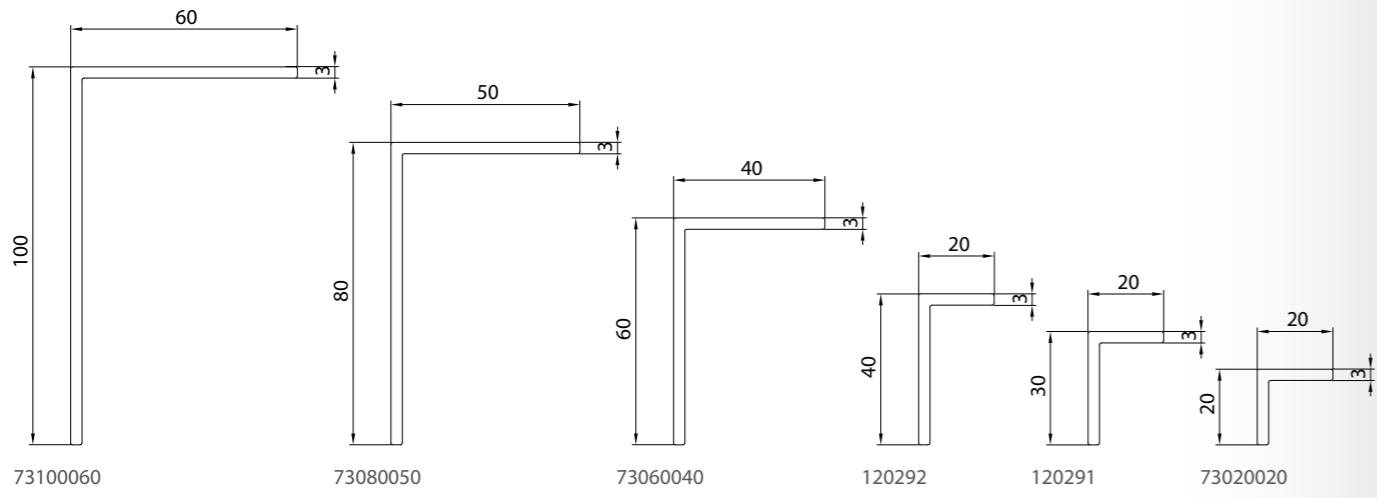

1:2

IDEAL





IDEAL

SALAMANDER[®]

WINDOW & DOOR SYSTEMS

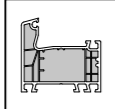
STREAMLINE 76

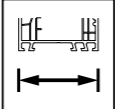
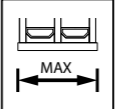
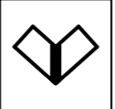

- 
5
- 
2
- 
76
- 
49
- 
**V-PERFECT
TECHNOLOGY**
- 
ALU



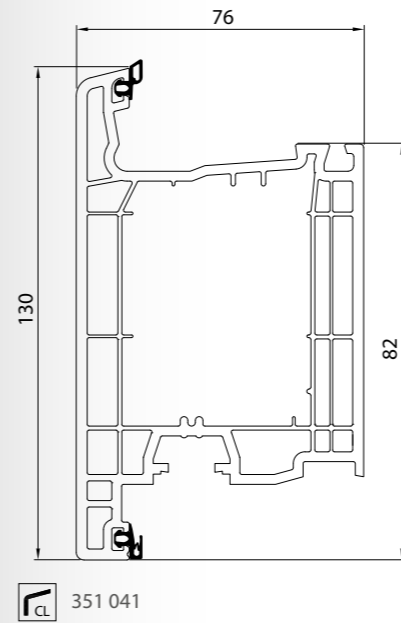
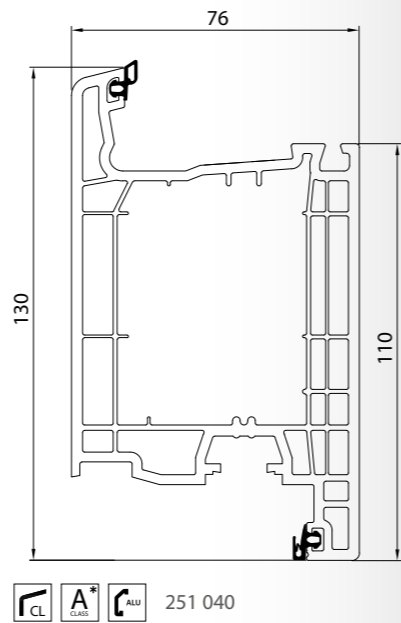
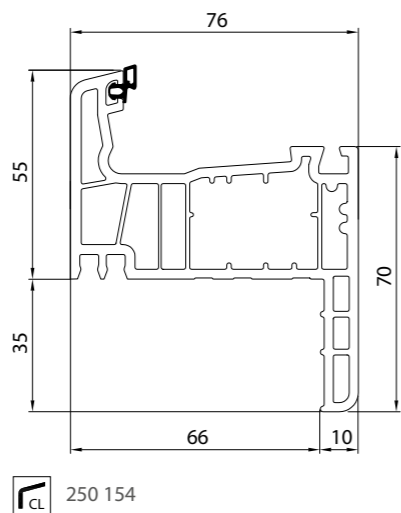
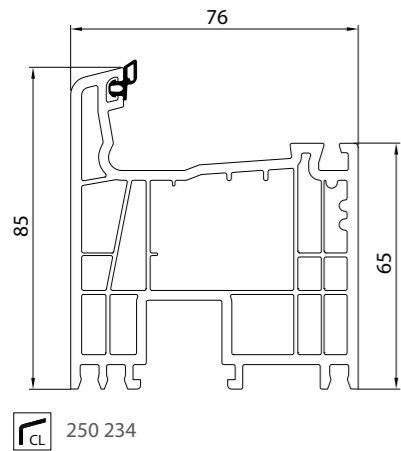
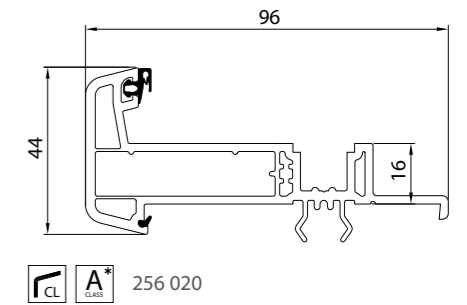
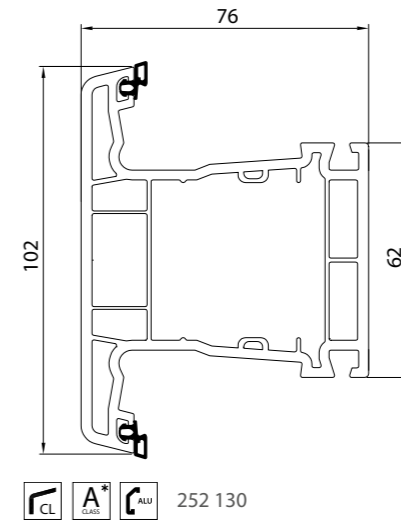
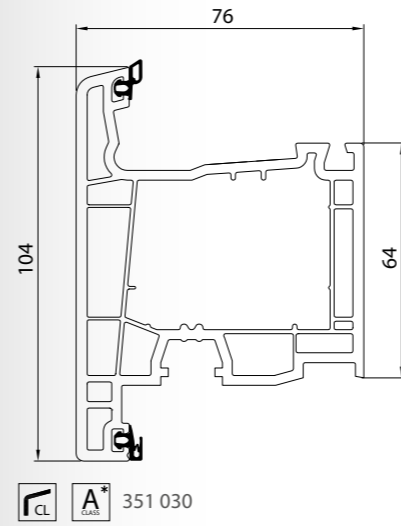
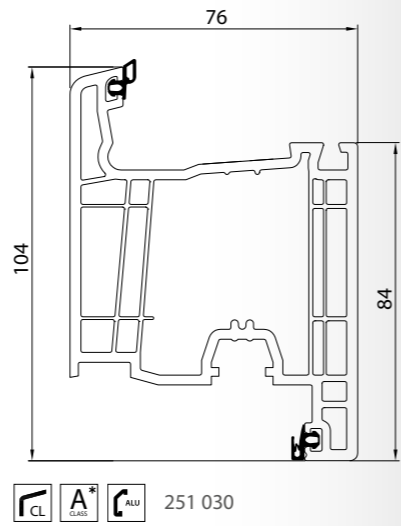
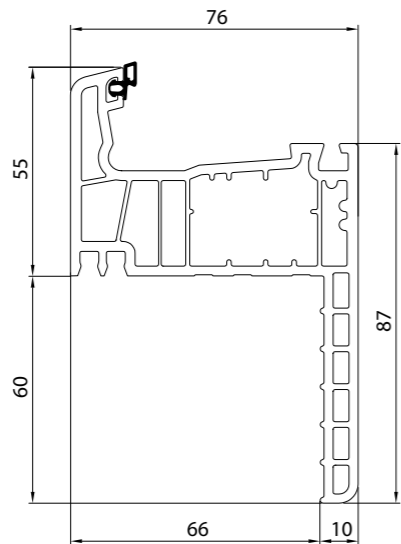
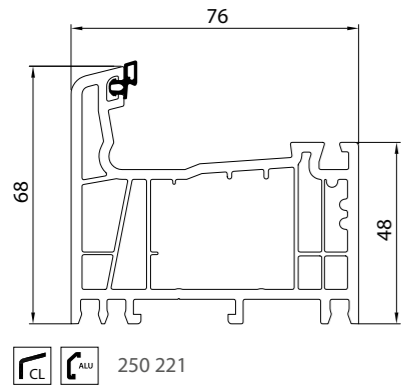
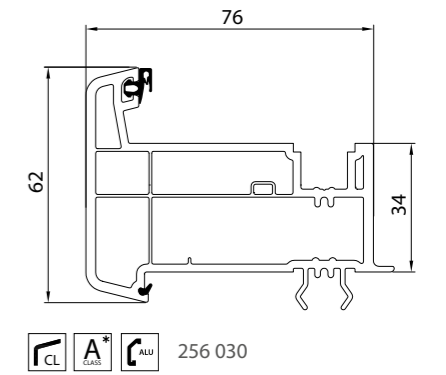
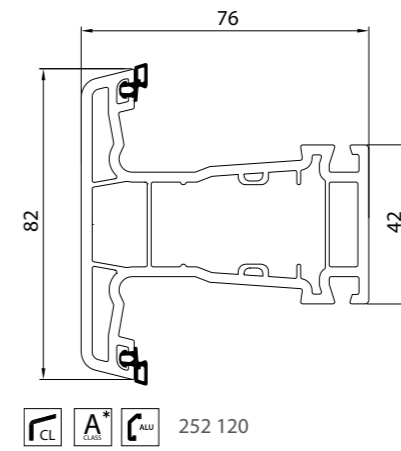
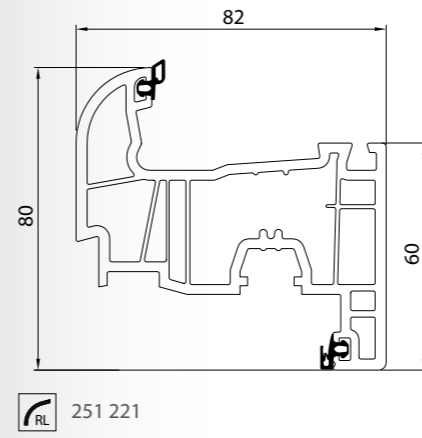
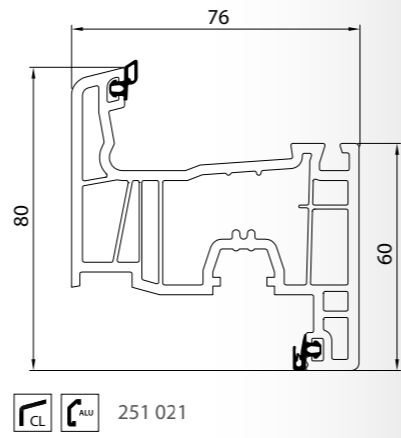
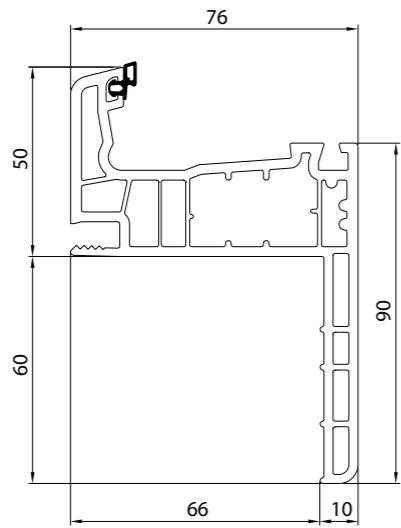
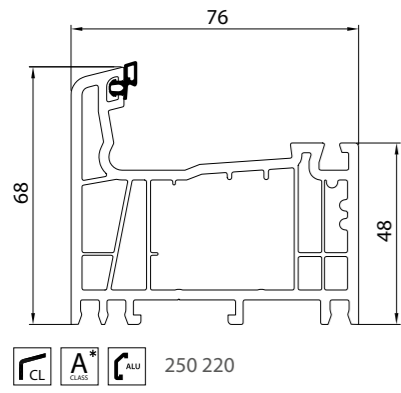

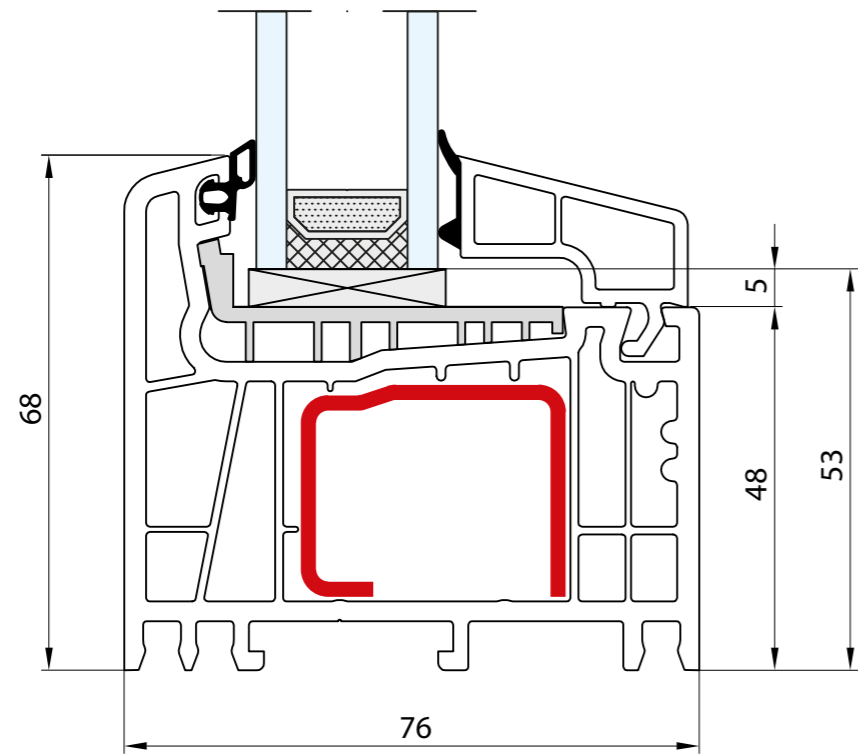

- Rama: 68 mm
- Dormant: 68 mm
- Frame: 68 mm
- Rahmen: 68 mm
- Telaio: 68 mm

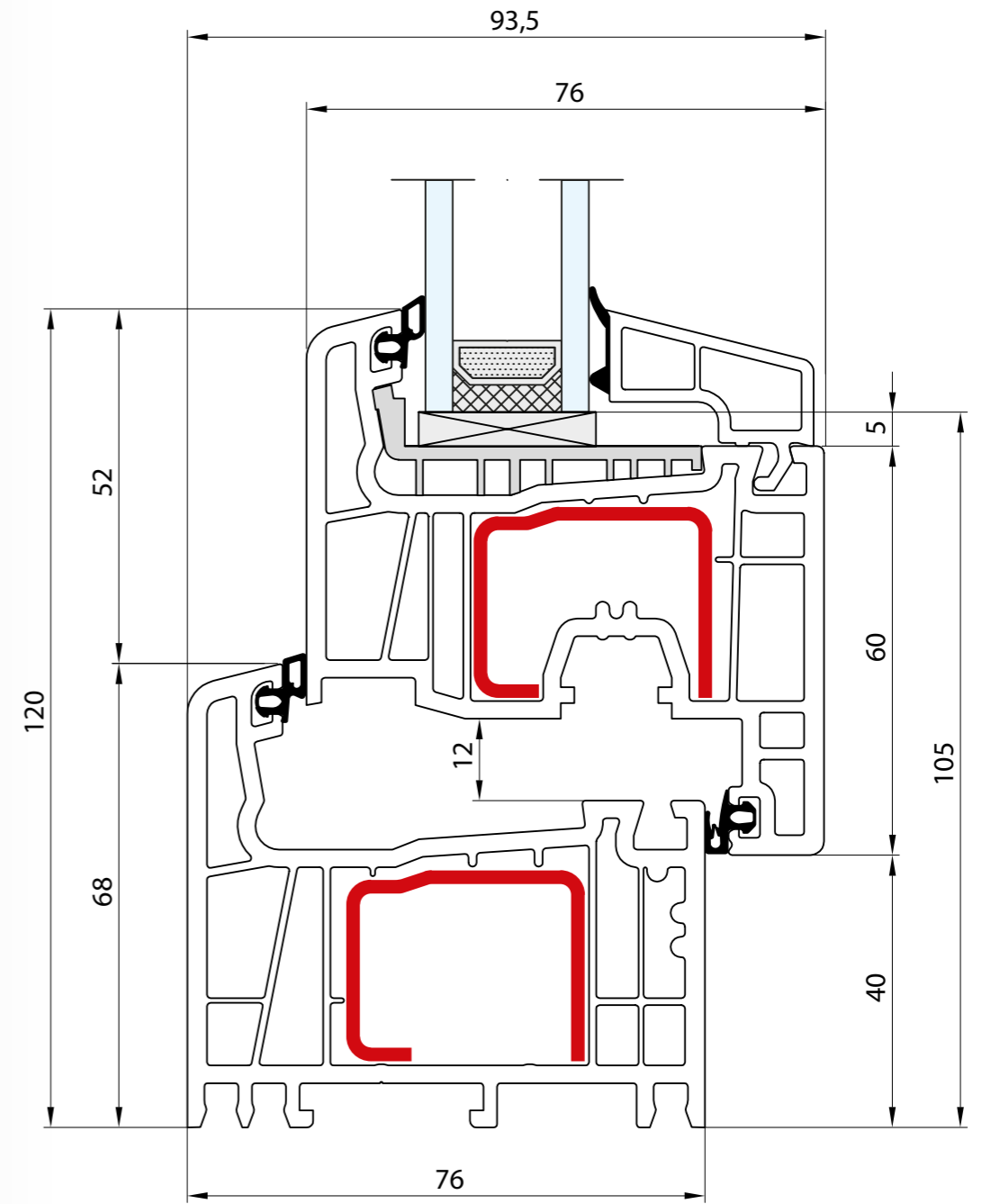
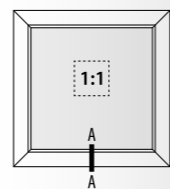

- Rama: 68 mm · Skrzydło: 80 mm
- Dormant: 68 mm · Vantail: 80 mm
- Frame: 68 mm · Sash: 80 mm
- Rahmen: 68 mm · Flügel: 80 mm
- Telaio: 68 mm · Anta: 80 mm

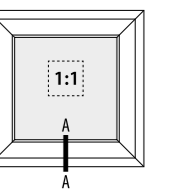

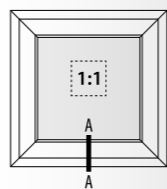
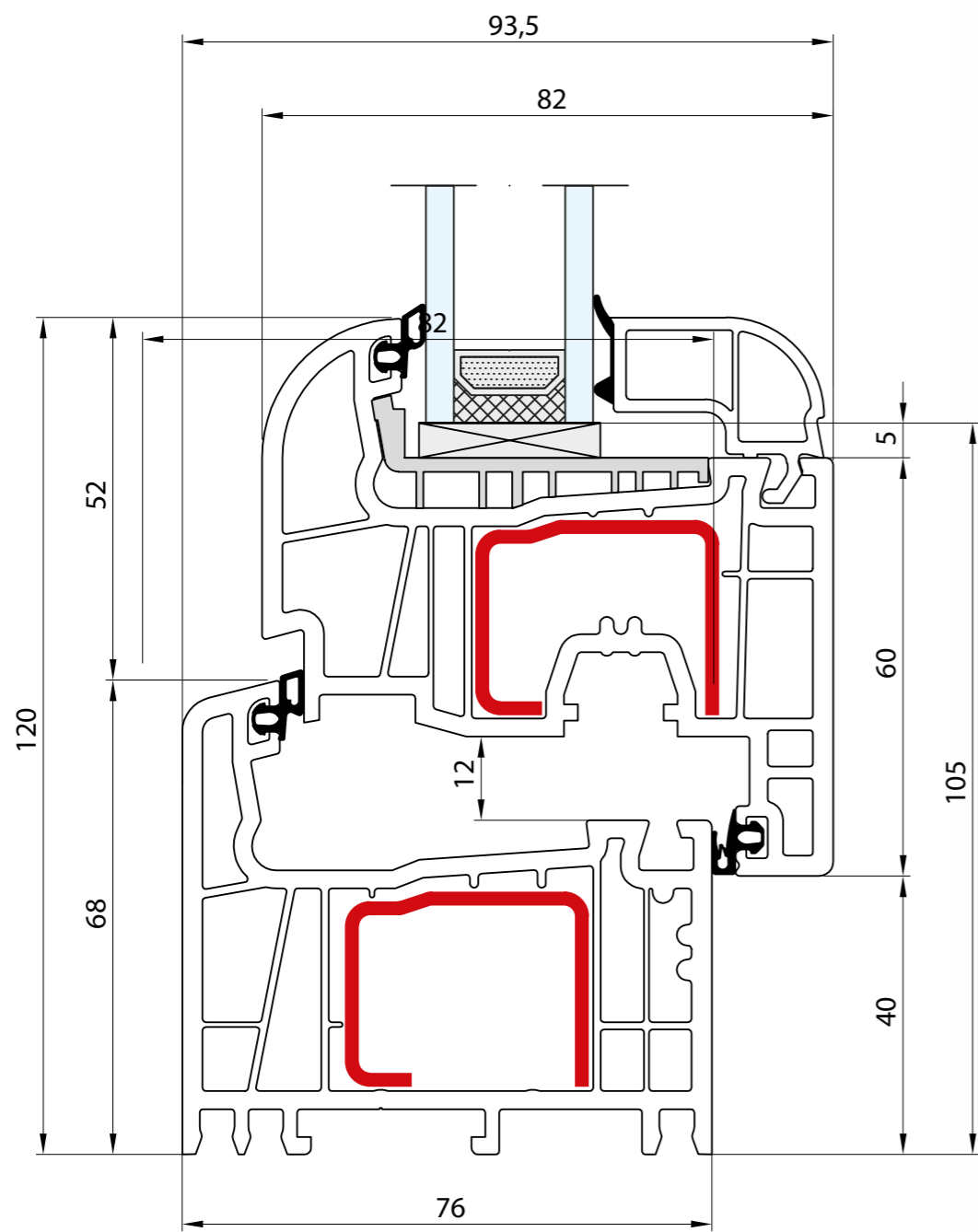

- Rama: 68 mm · Skrzydło: 80 mm
- Dormant: 68 mm · Vantail: 80 mm
- Frame: 68 mm · Sash: 80 mm
- Rahmen: 68 mm · Flügel: 80 mm
- Telaio: 68 mm · Anta: 80 mm

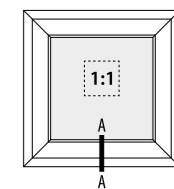
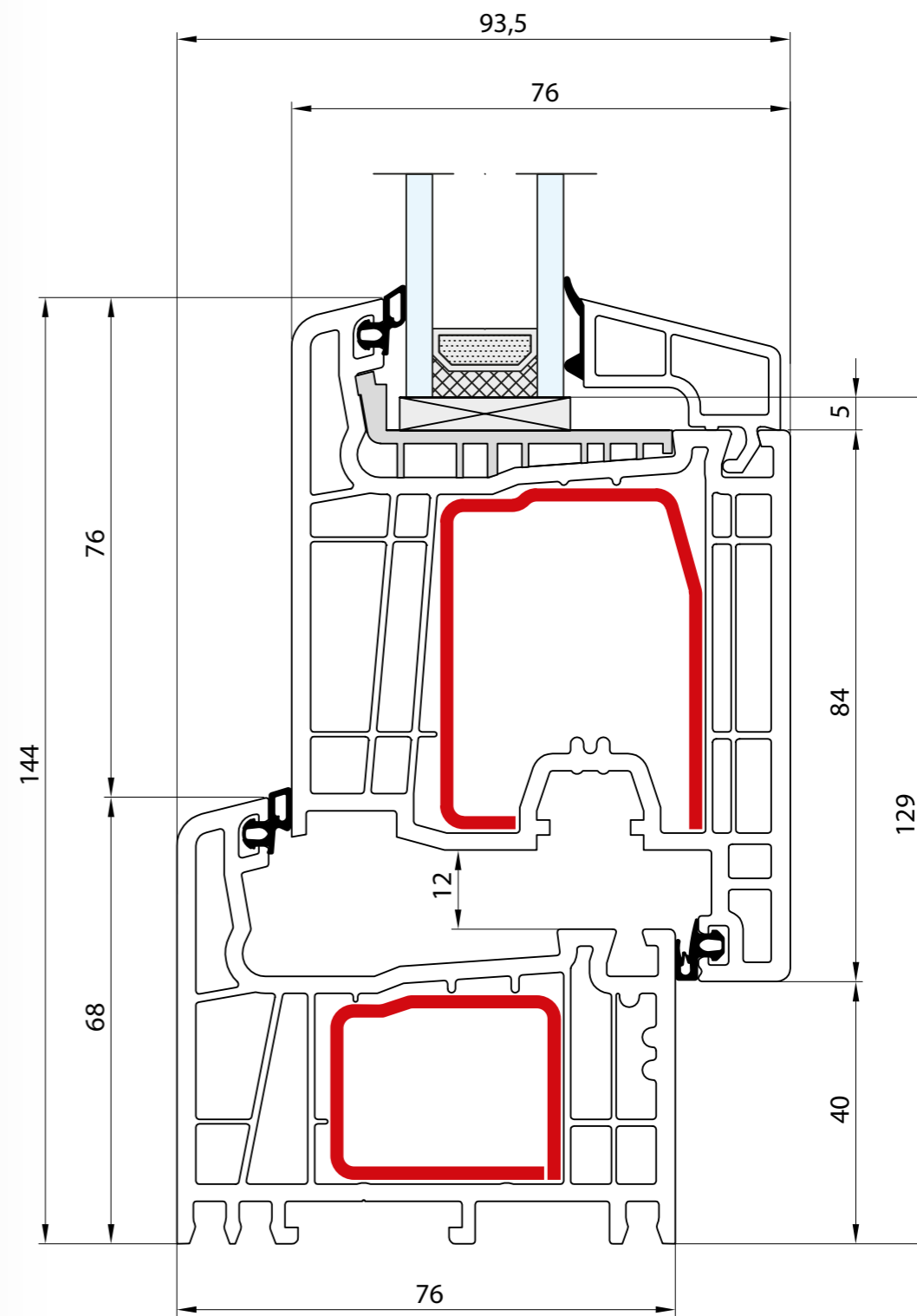

- Rama: 68 mm · Skrzydło: 104 mm
- Dormant: 68 mm · Vantail: 104 mm
- Frame: 68 mm · Sash: 104 mm
- Rahmen: 68 mm · Flügel: 104 mm
- Telaio: 68 mm · Anta: 104 mm

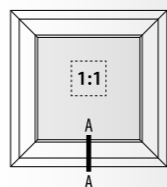
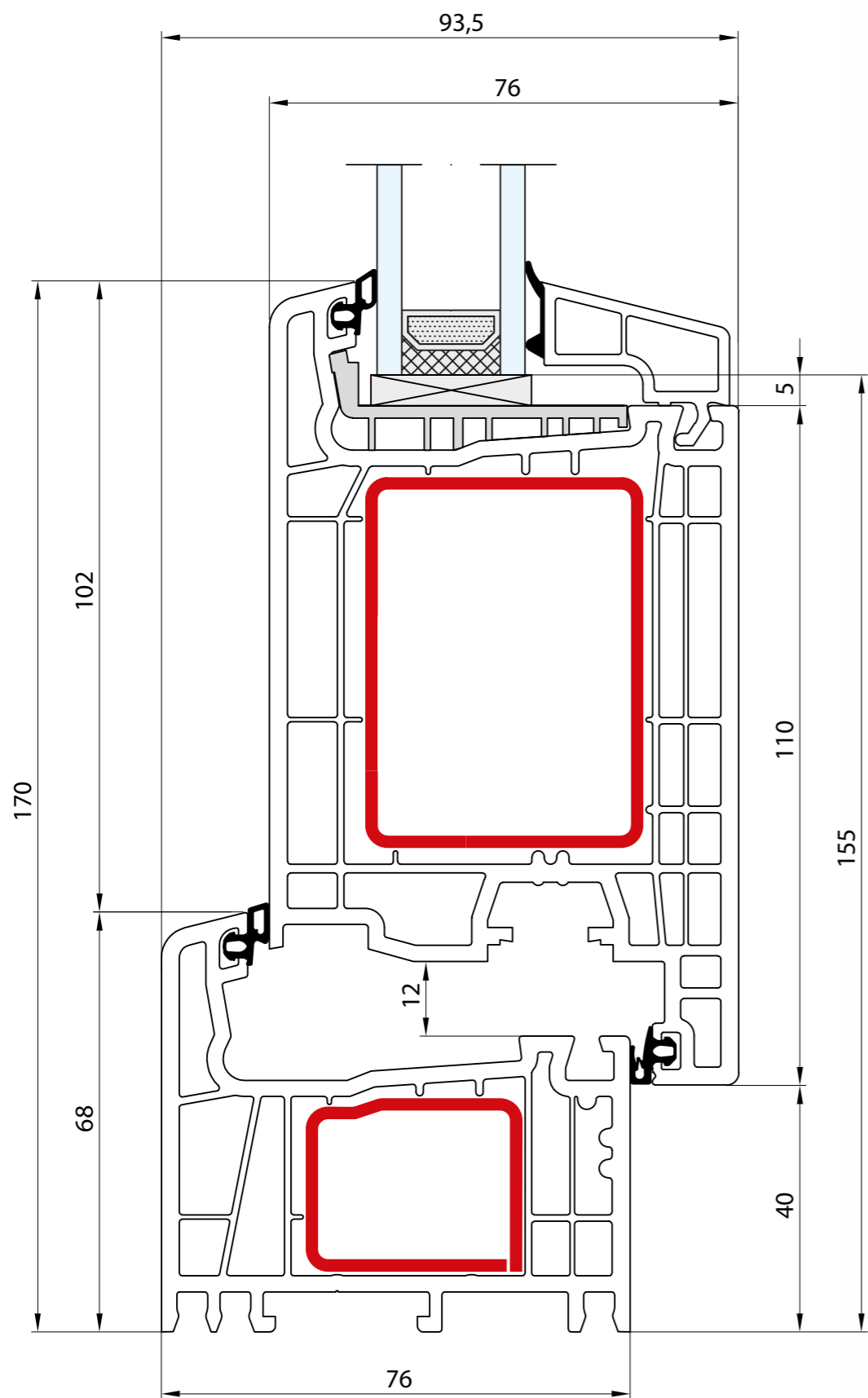

- Rama: 68 mm · Skrzydło: 130 mm
- Dormant: 68 mm · Vantail: 130 mm
- Frame: 68 mm · Sash: 130 mm
- Rahmen: 68 mm · Flügel: 130 mm
- Telaio: 68 mm · Anta: 130 mm

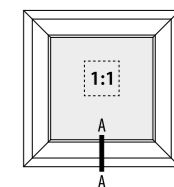
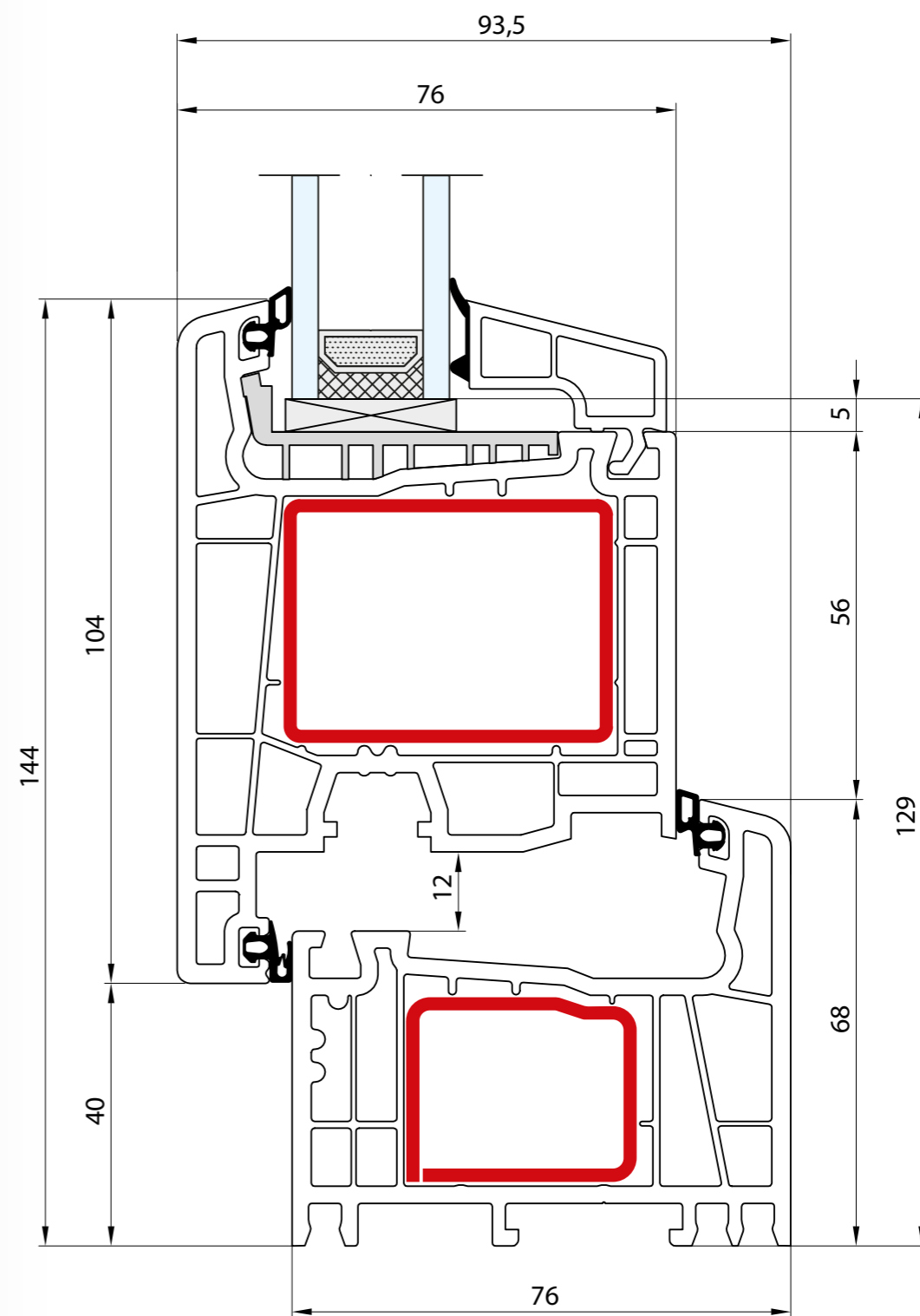

- Rama: 68 mm · Skrzydło: 104 mm
- Dormant: 68 mm · Vantail: 104 mm
- Frame: 68 mm · Sash: 104 mm
- Rahmen: 68 mm · Flügel: 104 mm
- Telaio: 68 mm · Anta: 104 mm

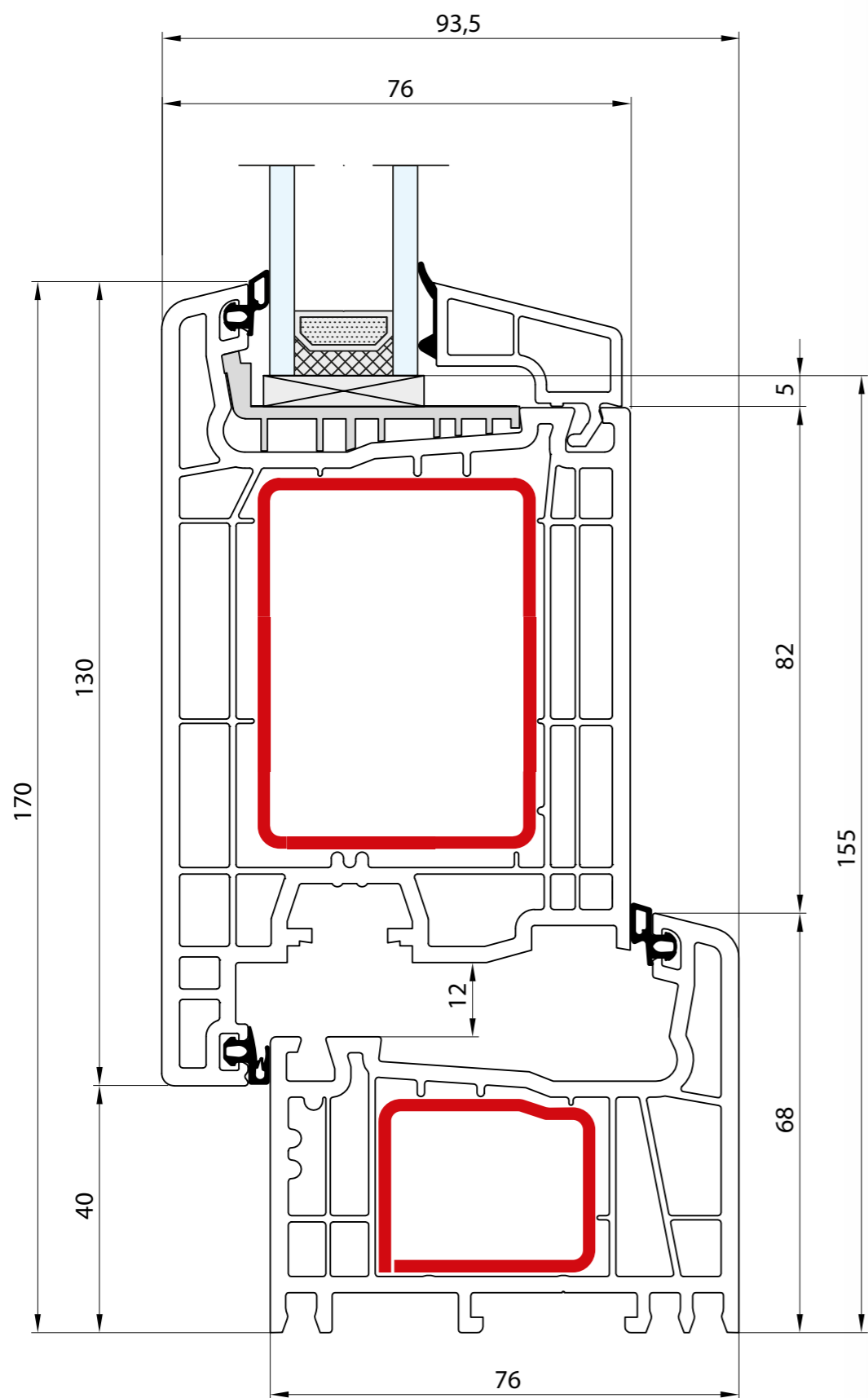

- Rama: 68 mm · Skrzydło: 130 mm
- Dormant: 68 mm · Vantail: 130 mm
- Frame: 68 mm · Sash: 130 mm
- Rahmen: 68 mm · Flügel: 130 mm
- Telaio: 68 mm · Anta: 130 mm

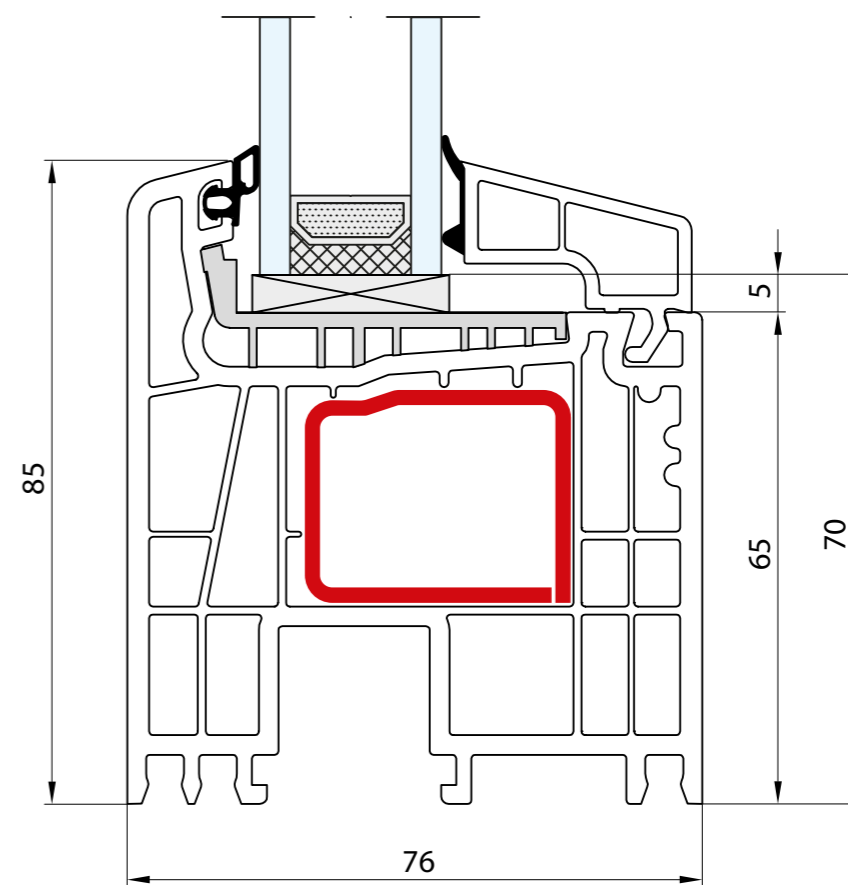
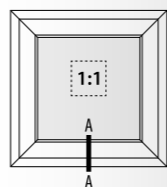

- Rama: 85 mm
- Dormant: 85 mm
- Frame: 85 mm
- Rahmen: 85 mm
- Telaio: 85 mm

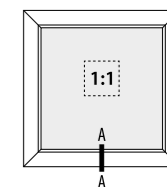

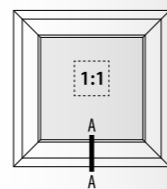
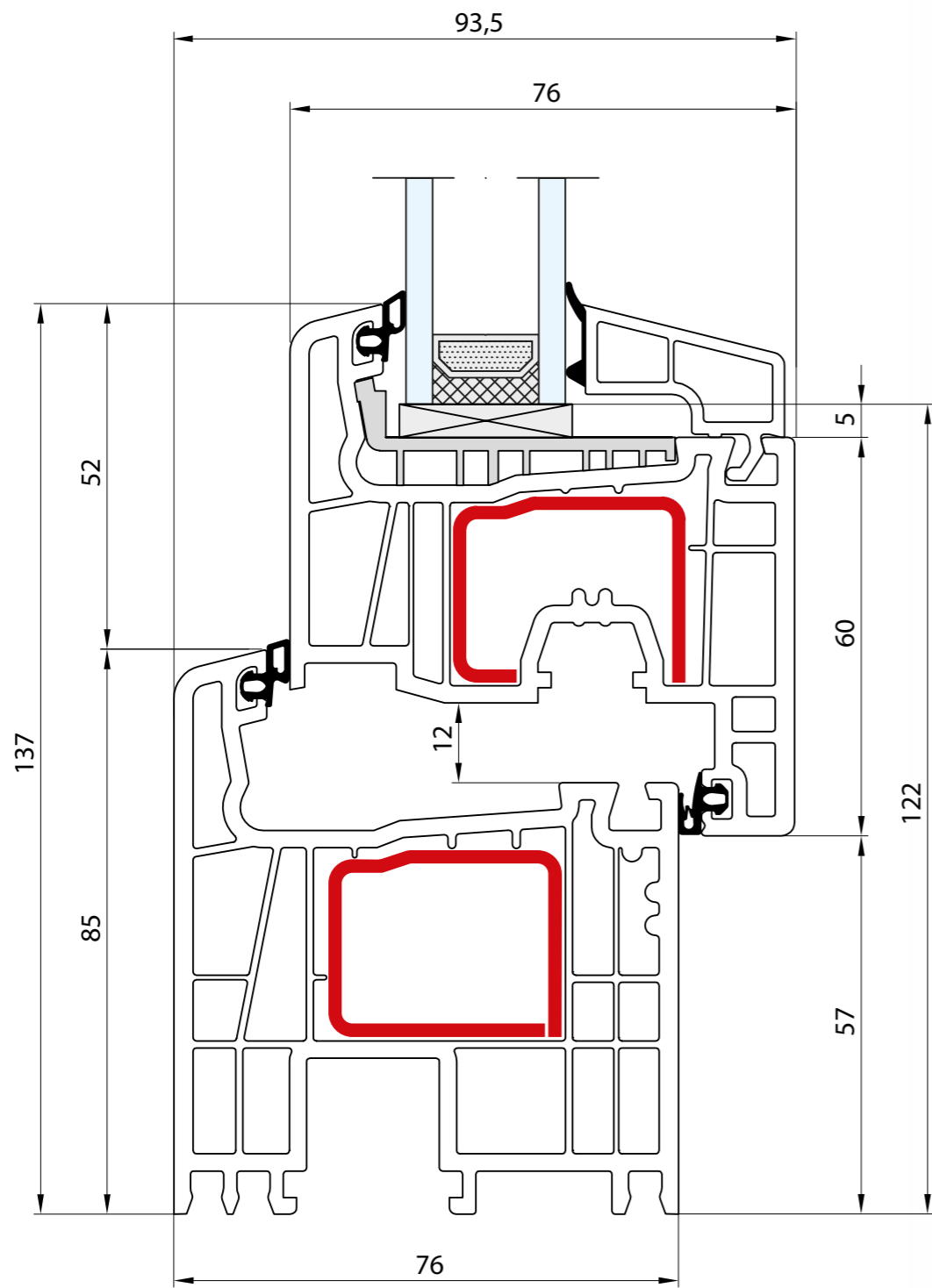

- Rama: 85 mm · Skrzydło: 80 mm
- Dormant: 85 mm · Vantail: 80 mm
- Frame: 85 mm · Sash: 80 mm
- Rahmen: 85 mm · Flügel: 80 mm
- Telaio: 85 mm · Anta: 80 mm

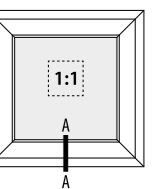
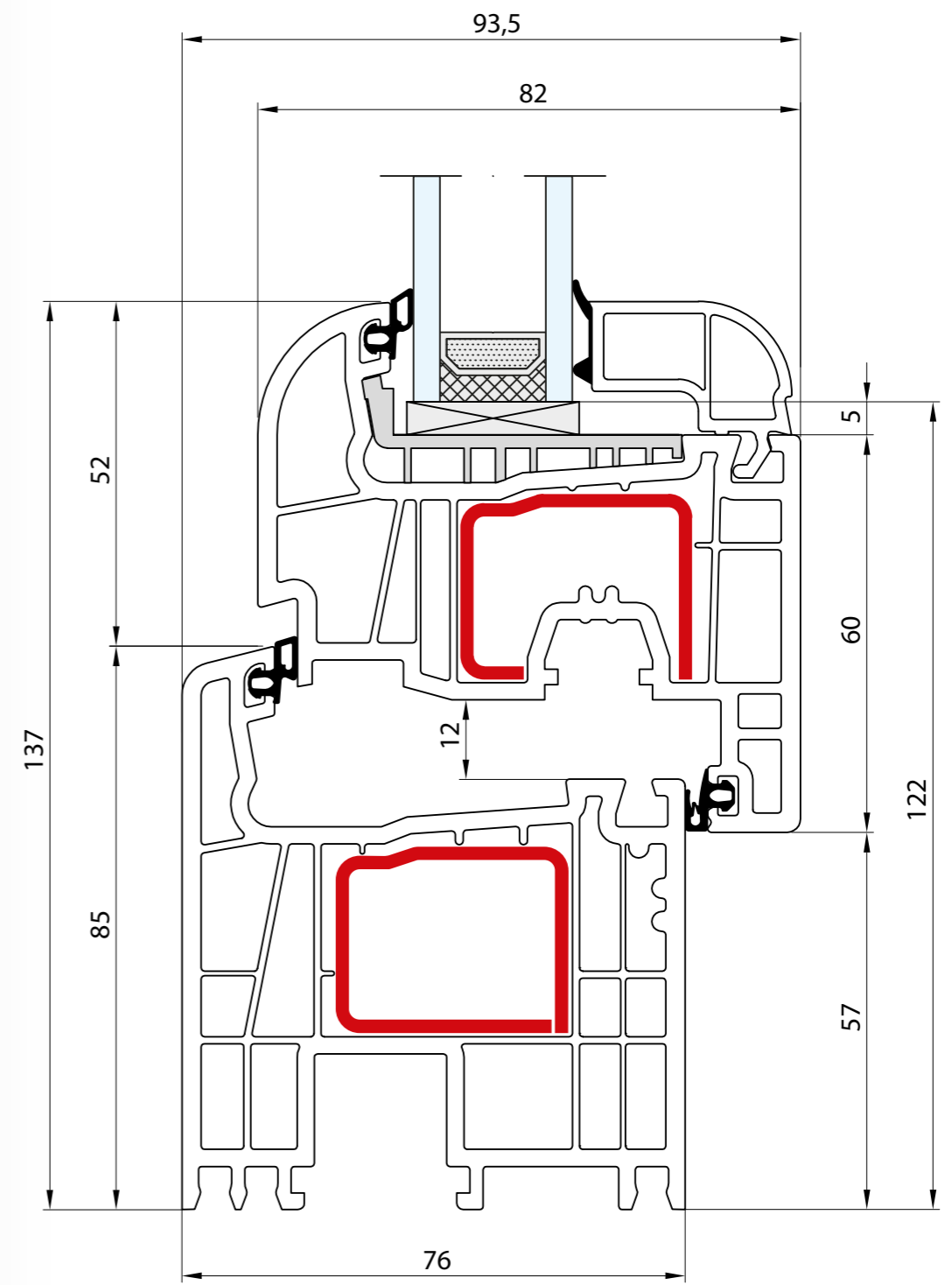

- Rama: 85 mm · Skrzydło: 80 mm
- Dormant: 85 mm · Vantail: 80 mm
- Frame: 85 mm · Sash: 80 mm
- Rahmen: 85 mm · Flügel: 80 mm
- Telaio: 85 mm · Anta: 80 mm

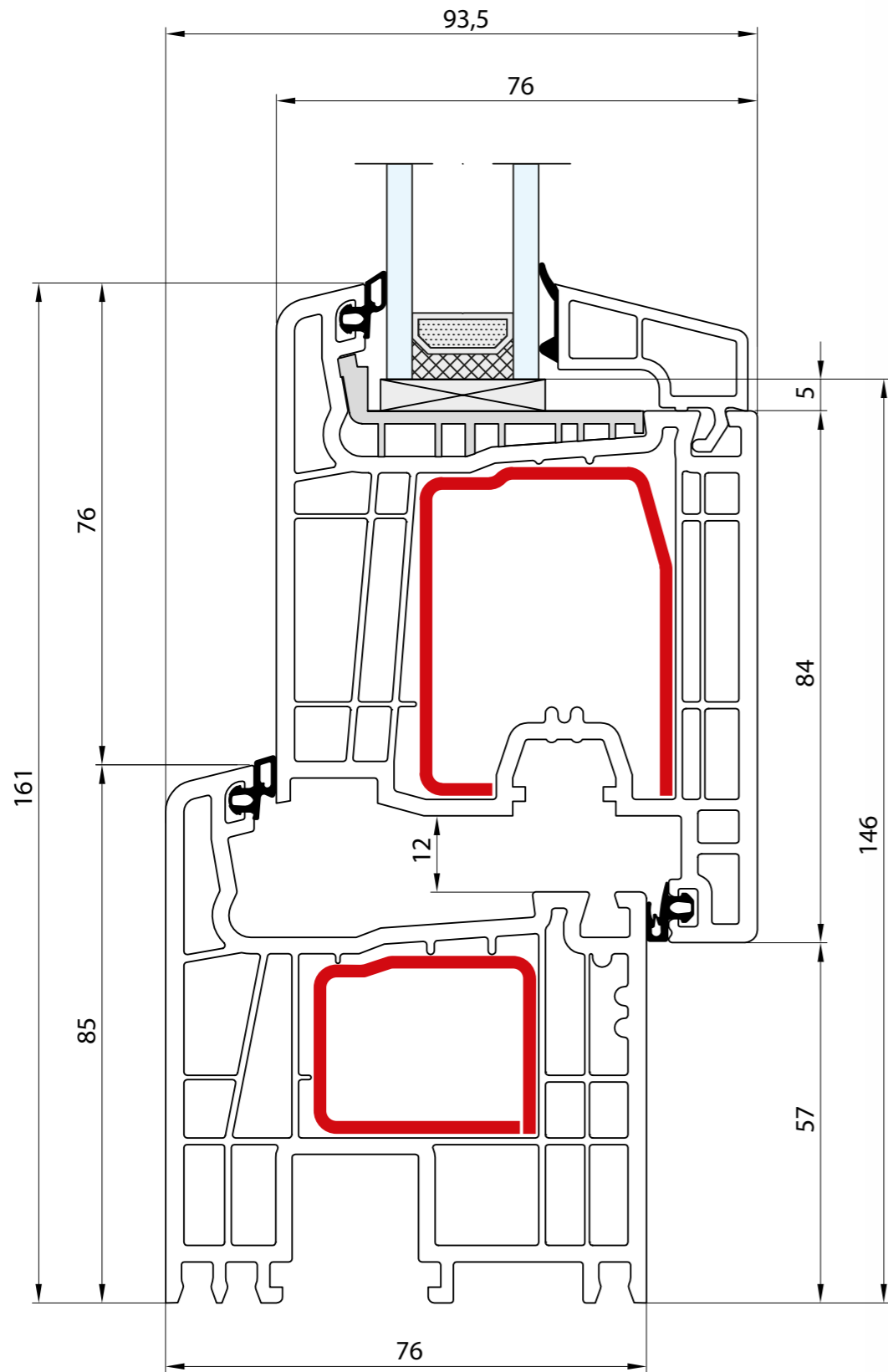

- Rama: 85 mm · Skrzydło: 104 mm
- Dormant: 85 mm · Vantail: 104 mm
- Frame: 85 mm · Sash: 104 mm
- Rahmen: 85 mm · Flügel: 104 mm
- Telaio: 85 mm · Anta: 104 mm

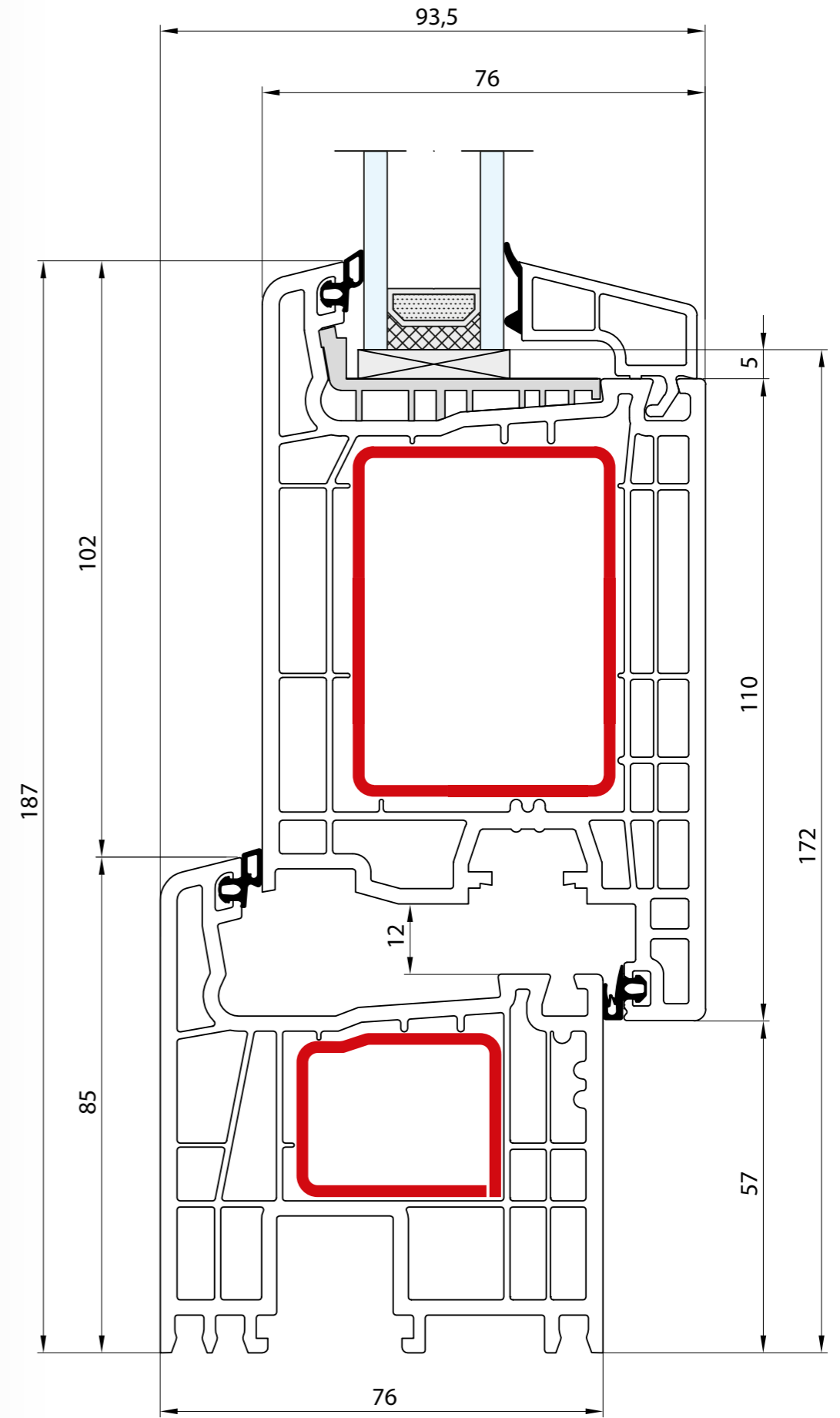
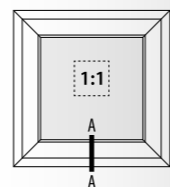

- Rama: 85 mm · Skrzydło: 130 mm
- Dormant: 85 mm · Vantail: 130 mm
- Frame: 85 mm · Sash: 130 mm
- Rahmen: 85 mm · Flügel: 130 mm
- Telaio: 85 mm · Anta: 130 mm

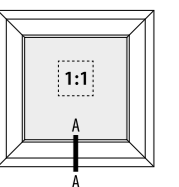

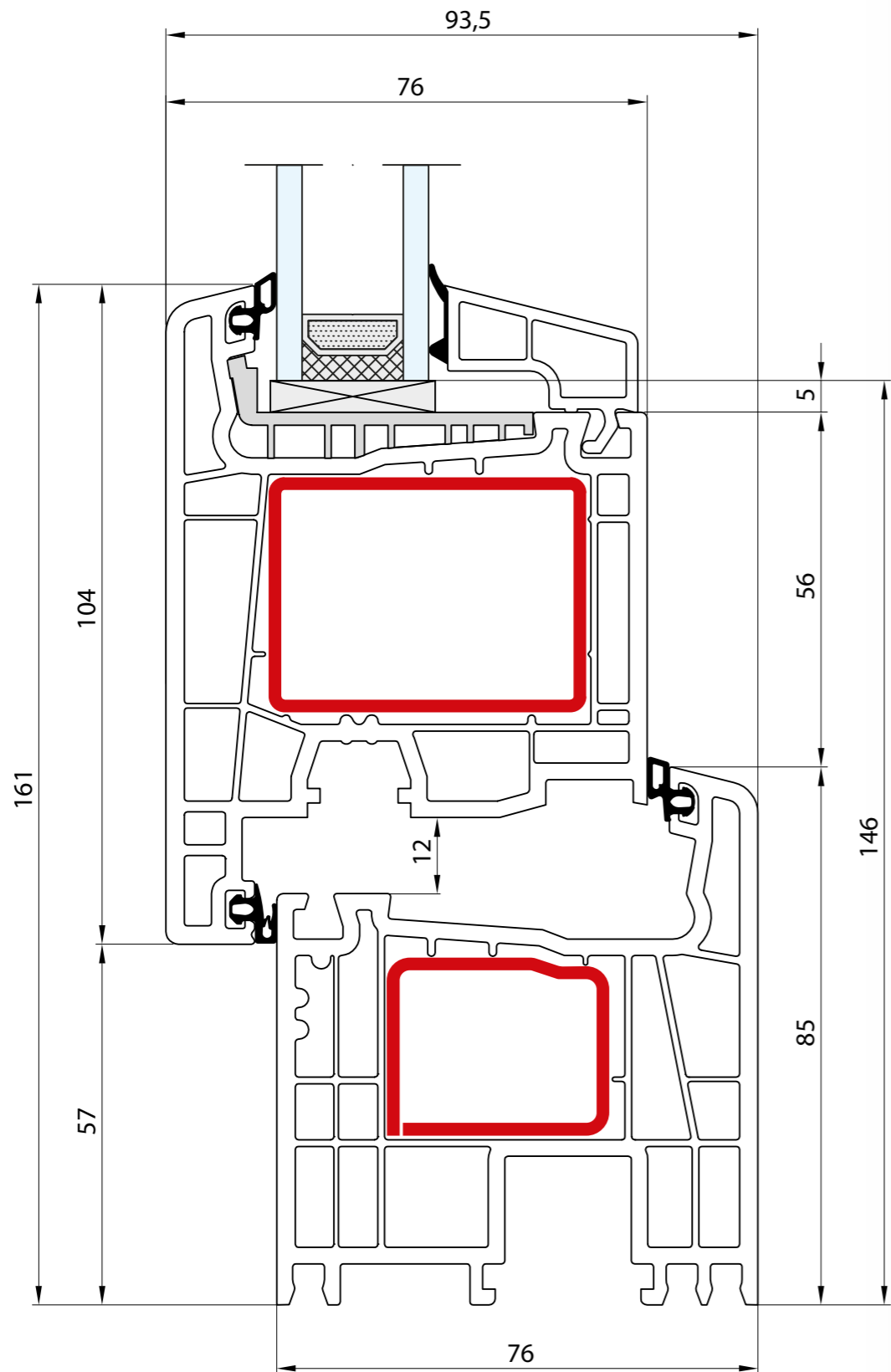

- Rama: 85 mm · Skrzydło: 104 mm
- Dormant: 85 mm · Vantail: 104 mm
- Frame: 85 mm · Sash: 104 mm
- Rahmen: 85 mm · Flügel: 104 mm
- Telaio: 85 mm · Anta: 104 mm

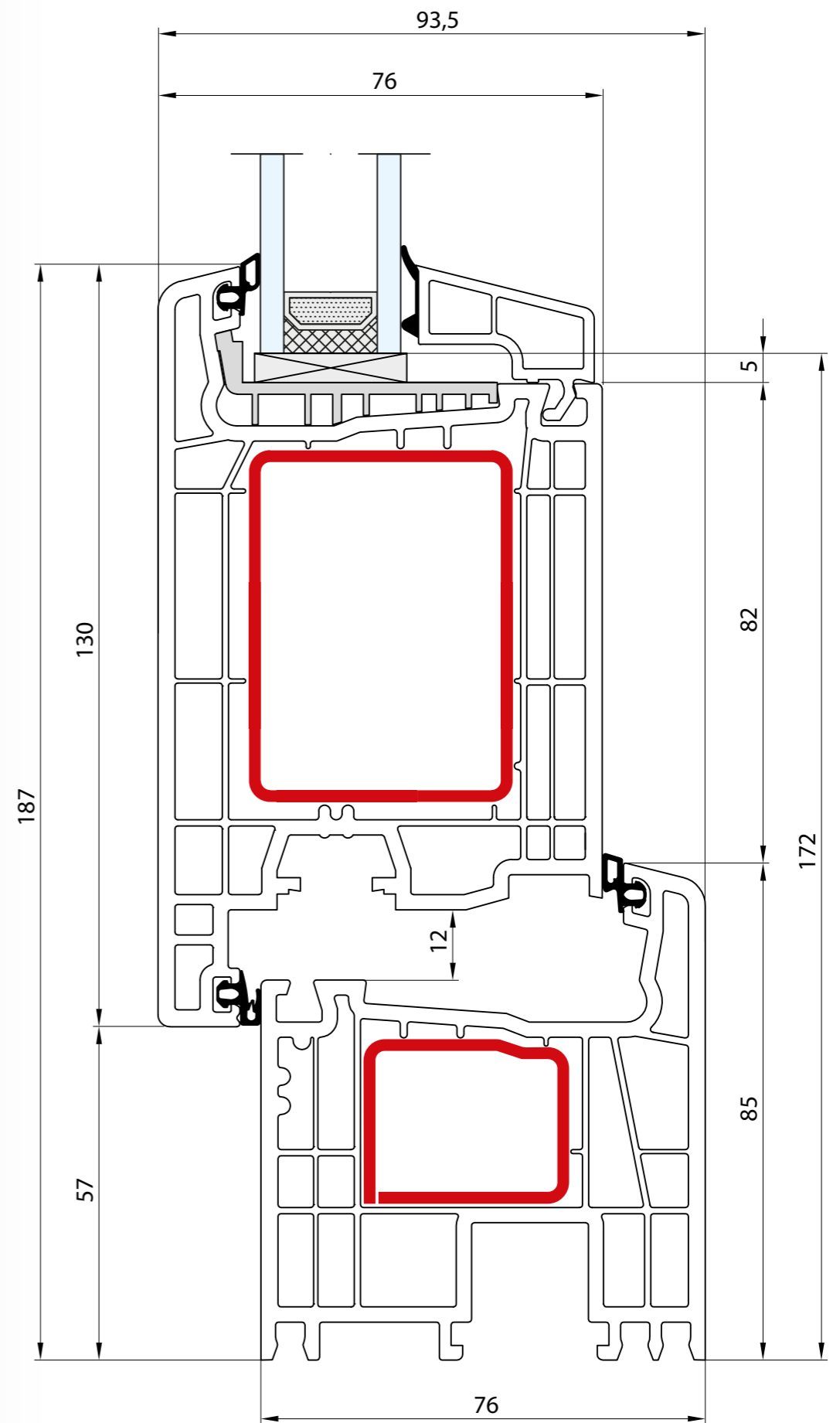
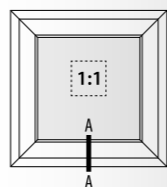

- Rama: 85 mm · Skrzydło: 130 mm
- Dormant: 85 mm · Vantail: 130 mm
- Frame: 85 mm · Sash: 130 mm
- Rahmen: 85 mm · Flügel: 130 mm
- Telaio: 85 mm · Anta: 130 mm

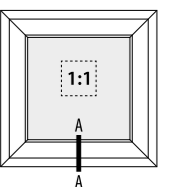

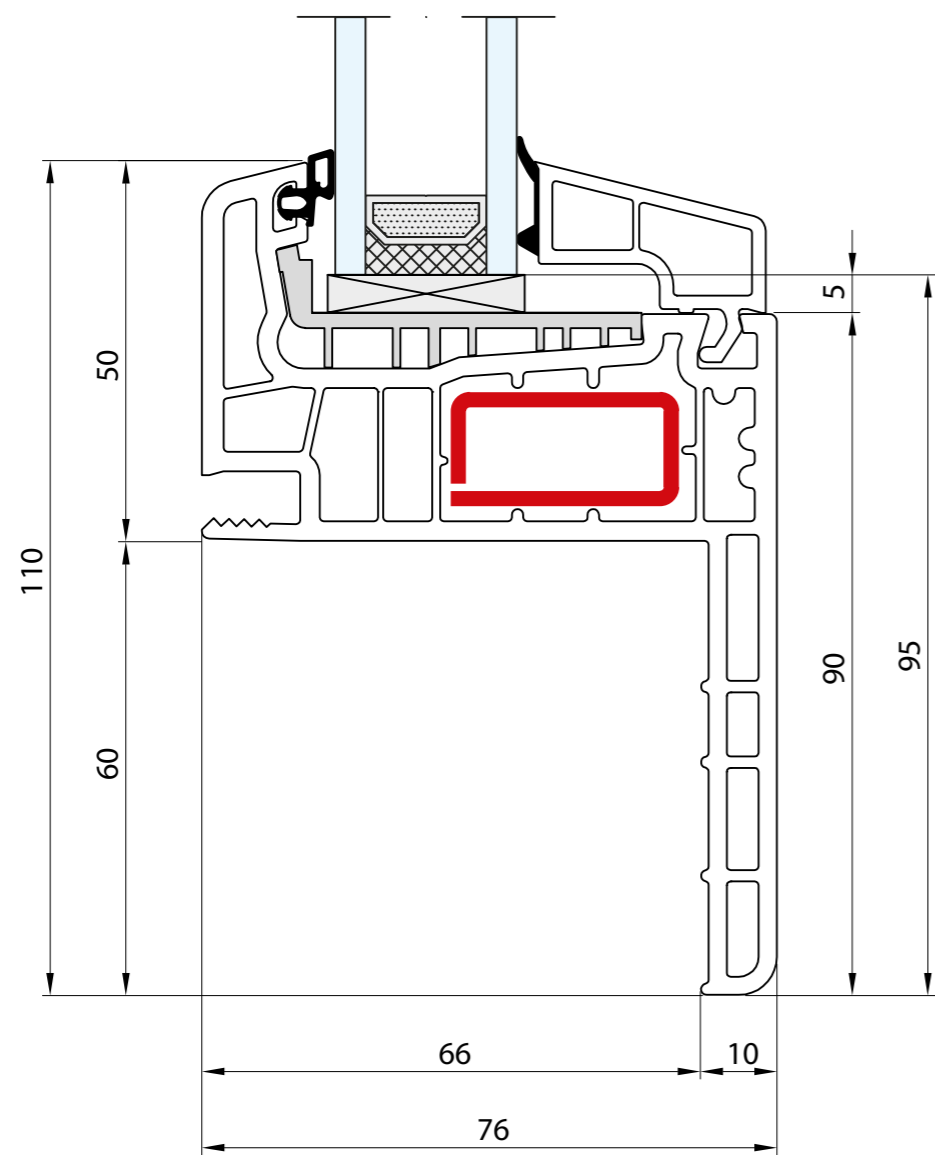

- RENOWACJA - Pletwa: 60 mm · Rama: 50 mm
- RÉNOVATION - Lip: 60 mm · Dormant: 50 mm
- RENOVATION - Strip: 60 mm · Frame: 50 mm
- RENOVIERUNG - Flosse: 60 mm · Rahmen: 50 mm
- RINNOVAZIONE - Aletta da: 60 mm · Telaio: 50 mm

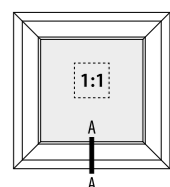
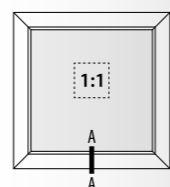

A

A

1:1

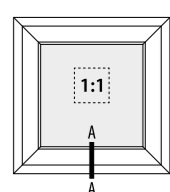

A

A

1:1

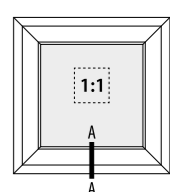

A

A

1:1

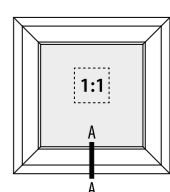

A

A

1:1

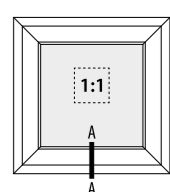

A

A

1:1

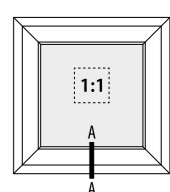

A

A

1:1

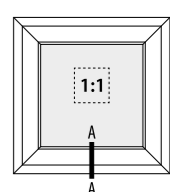

A

A

1:1

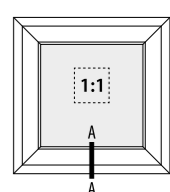

A

A

1:1

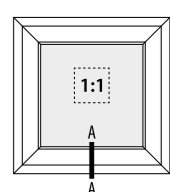

A

A

1:1

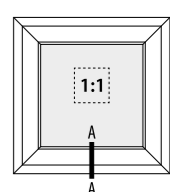

A

A

1:1

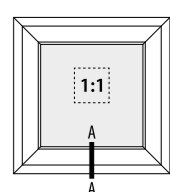

A

A

1:1

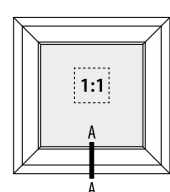

A

A

1:1

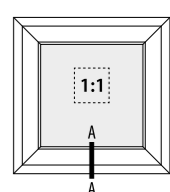

A

A

1:1

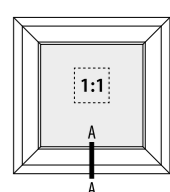

A

A

1:1

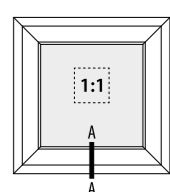

A

A

1:1

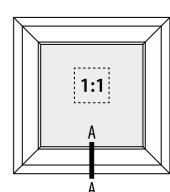

A

A

1:1

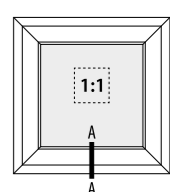

A

A

1:1

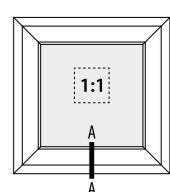

A

A

1:1

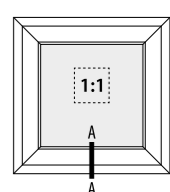

A

A

1:1

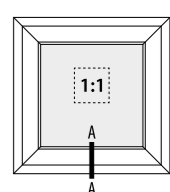

A

A

1:1

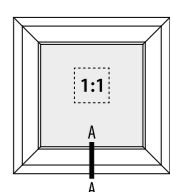

A

A

1:1

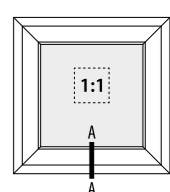

A

A

1:1

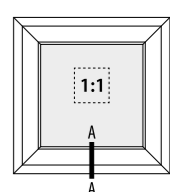

A

A

1:1

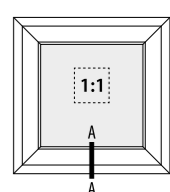

A

A

1:1

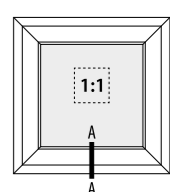

A

A

1:1

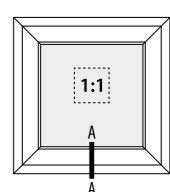

A

A

1:1

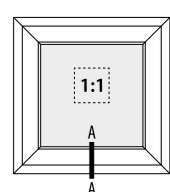

A

A

1:1

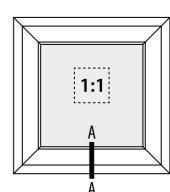

A

A

1:1

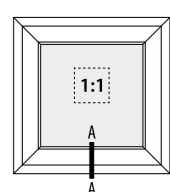

A

A

1:1

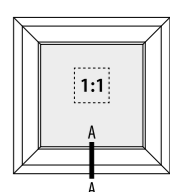

A

A

1:1

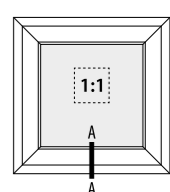

A

A

1:1

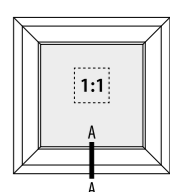

A

A

1:1

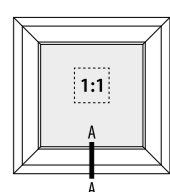

A

A

1:1

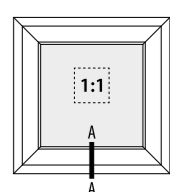

A

A

1:1

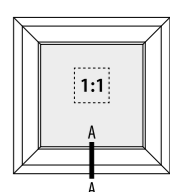

A

A

1:1

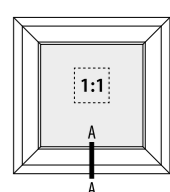

A

A

1:1

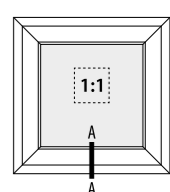

A

A

1:1

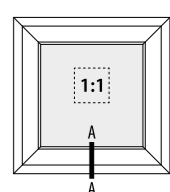

A

A

1:1

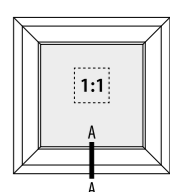

A

A

1:1

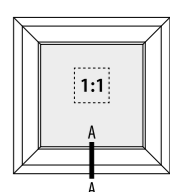

A

A

1:1

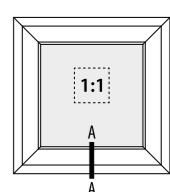

A

A

1:1

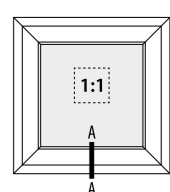

A

A

1:1

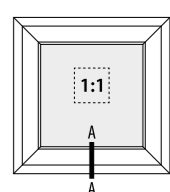

A

A

1:1

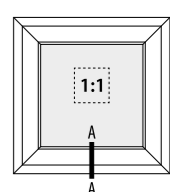

A

A

1:1

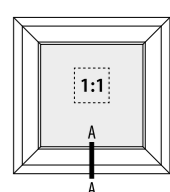

A

A

1:1

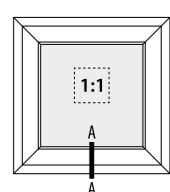

A

A

1:1

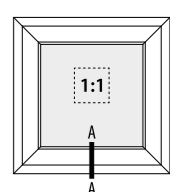

A

A

1:1

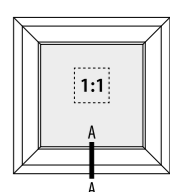

A

A

1:1

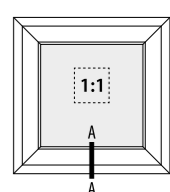

A

A

1:1

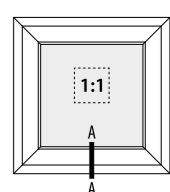

A

A

1:1

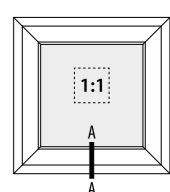

A

A

1:1

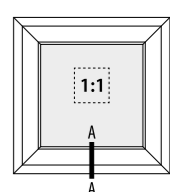

A

A

1:1

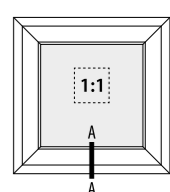

A

A

1:1

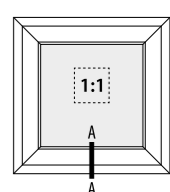

A

A

1:1

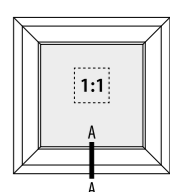

A

A

1:1

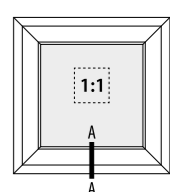

A

A

1:1

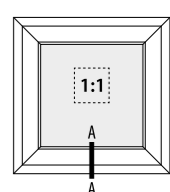

A

A

1:1

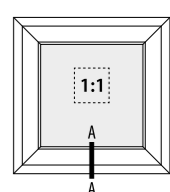

A

A

1:1

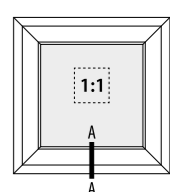

A

A

1:1

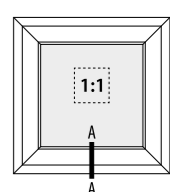

A

A

1:1

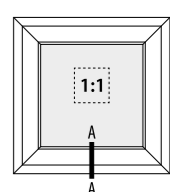

A

A

1:1

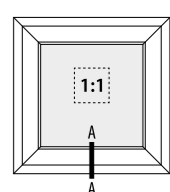

A

A

1:1

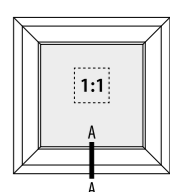

A

A

1:1

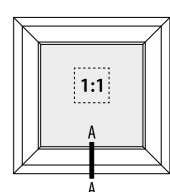

A

A

1:1

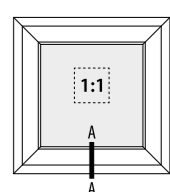

A

A

1:1

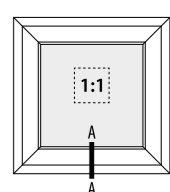

A

A

1:1

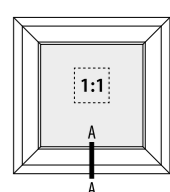

A

A

1:1

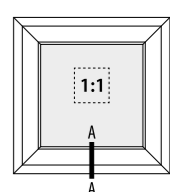

A

A

1:1

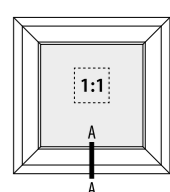

A

A

1:1

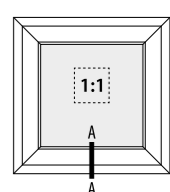

A

A

1:1

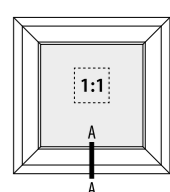

A

A

1:1

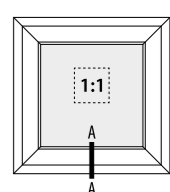

A

A

1:1

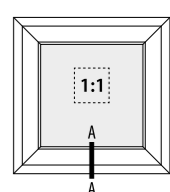

A

A

1:1

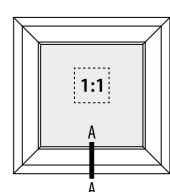

A

A

1:1

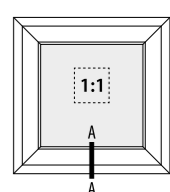

A

A

1:1

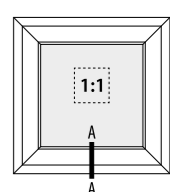

A

A

1:1

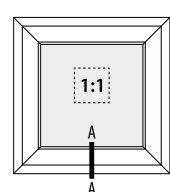

A

A

1:1

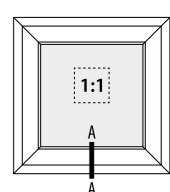

A

A

1:1

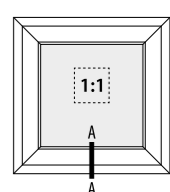

A

A

1:1

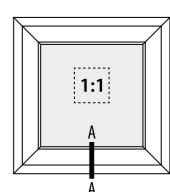

A

A

1:1

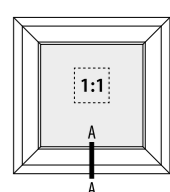

A

A

1:1

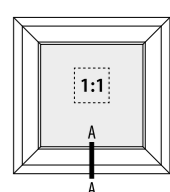

A

A

1:1

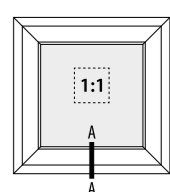

A

A

1:1

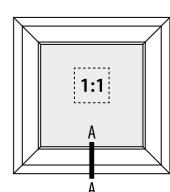

A

A

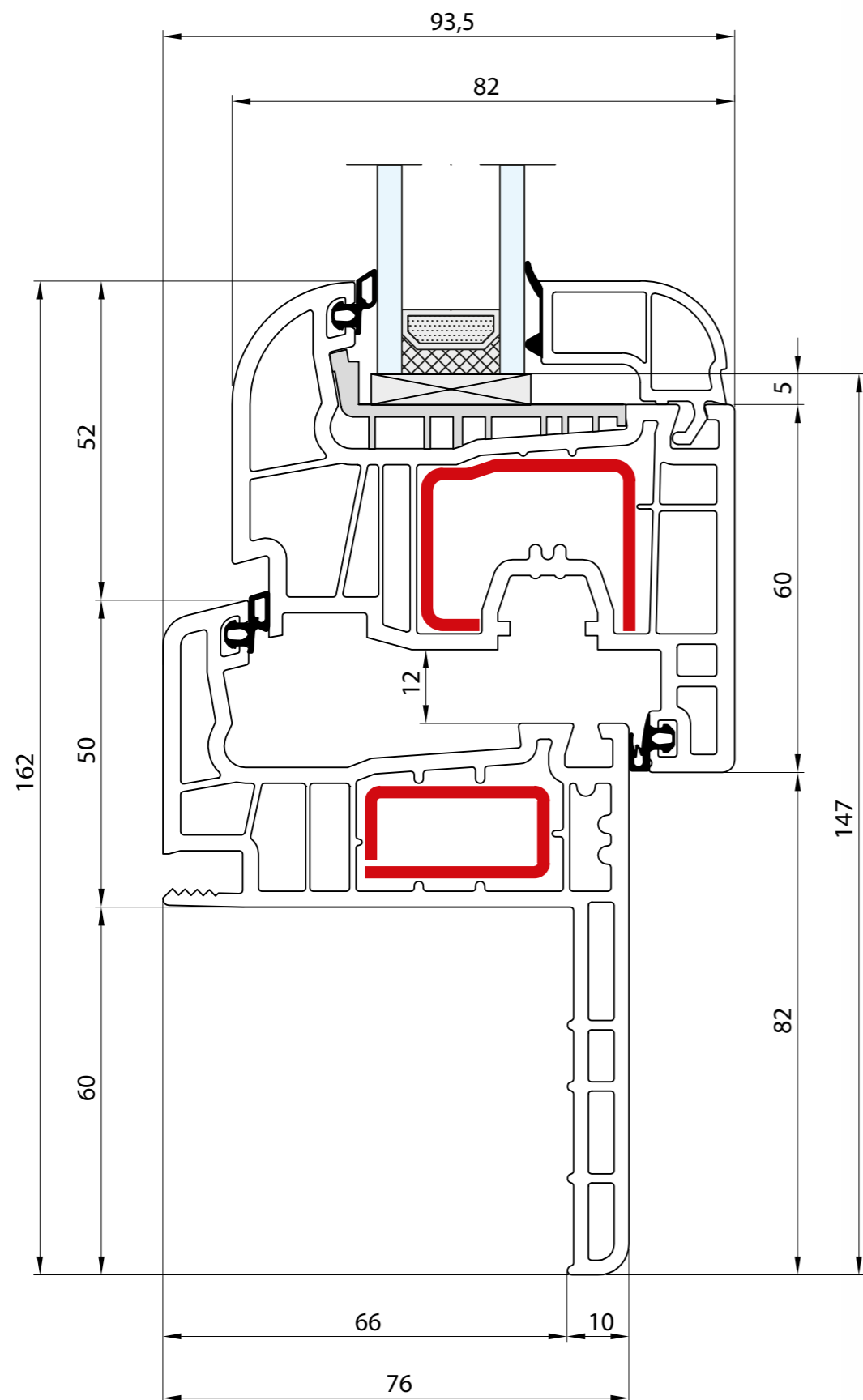

- RENOWACJA - Pletwa: 60 mm · Rama: 50 mm · Skrzydło: 80 mm
- RÉNOVATION - Lip: 60 mm · Dormant: 50 mm · Vantail: 80 mm
- RENOVATION - Strip: 60 mm · Frame: 50 mm · Sash: 80 mm
- RENOVIERUNG - Flosse: 60 mm · Rahmen: 50 mm · Flügel: 80 mm
- RINNOVAZIONE - Aletta da: 60 mm · Telaio: 50 mm · Anta: 80 mm

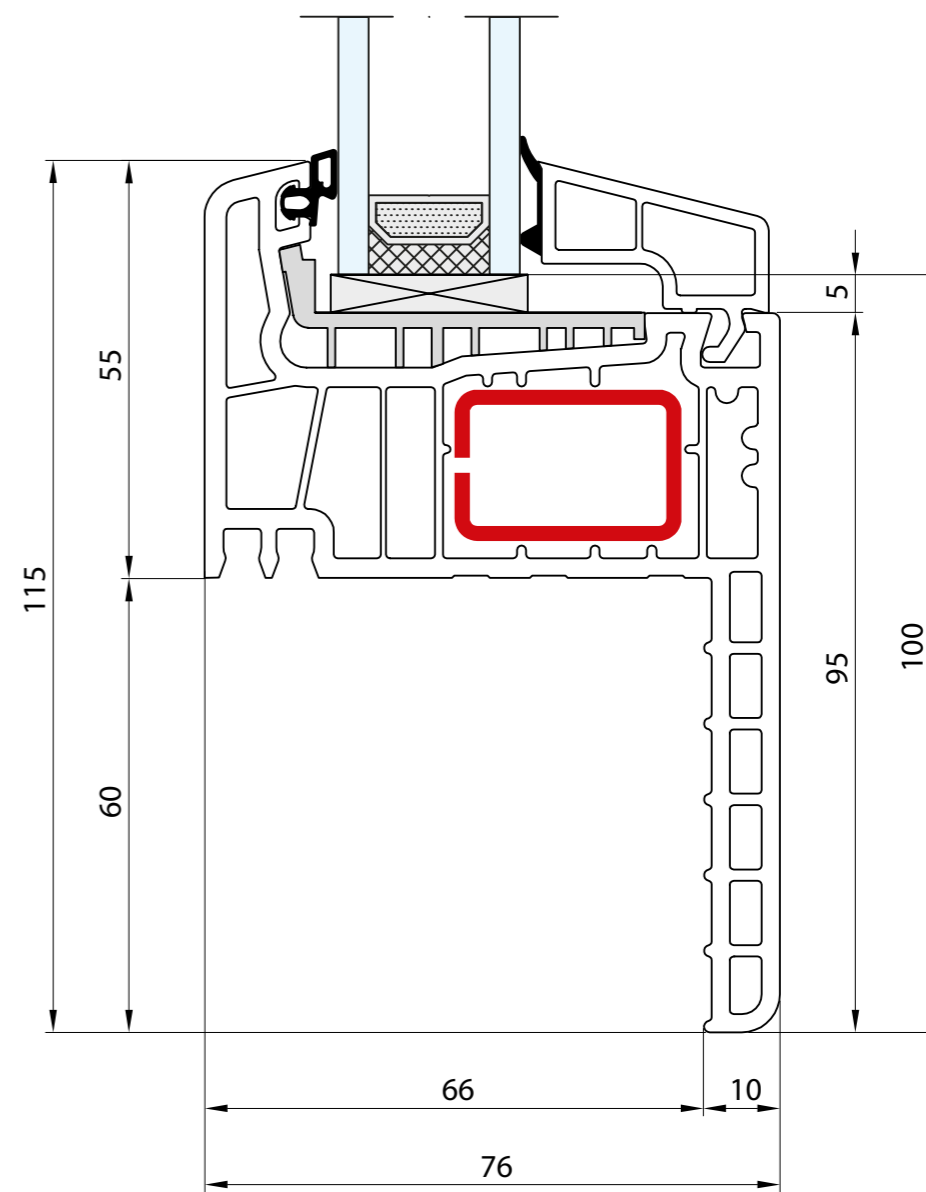
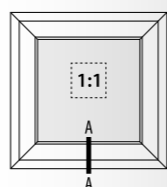

- RENOWACJA - Pletwa: 60 mm · Rama: 55 mm
- RÉNOVATION - Lip: 60 mm · Dormant: 55 mm
- RENOVATION - Strip: 60 mm · Frame: 55 mm
- RENOVIERUNG - Flosse: 60 mm · Rahmen: 55 mm
- RINNOVAZIONE - Aletta da: 60 mm · Telaio: 55 mm

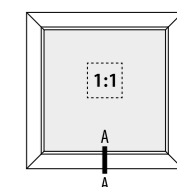

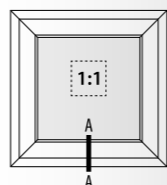
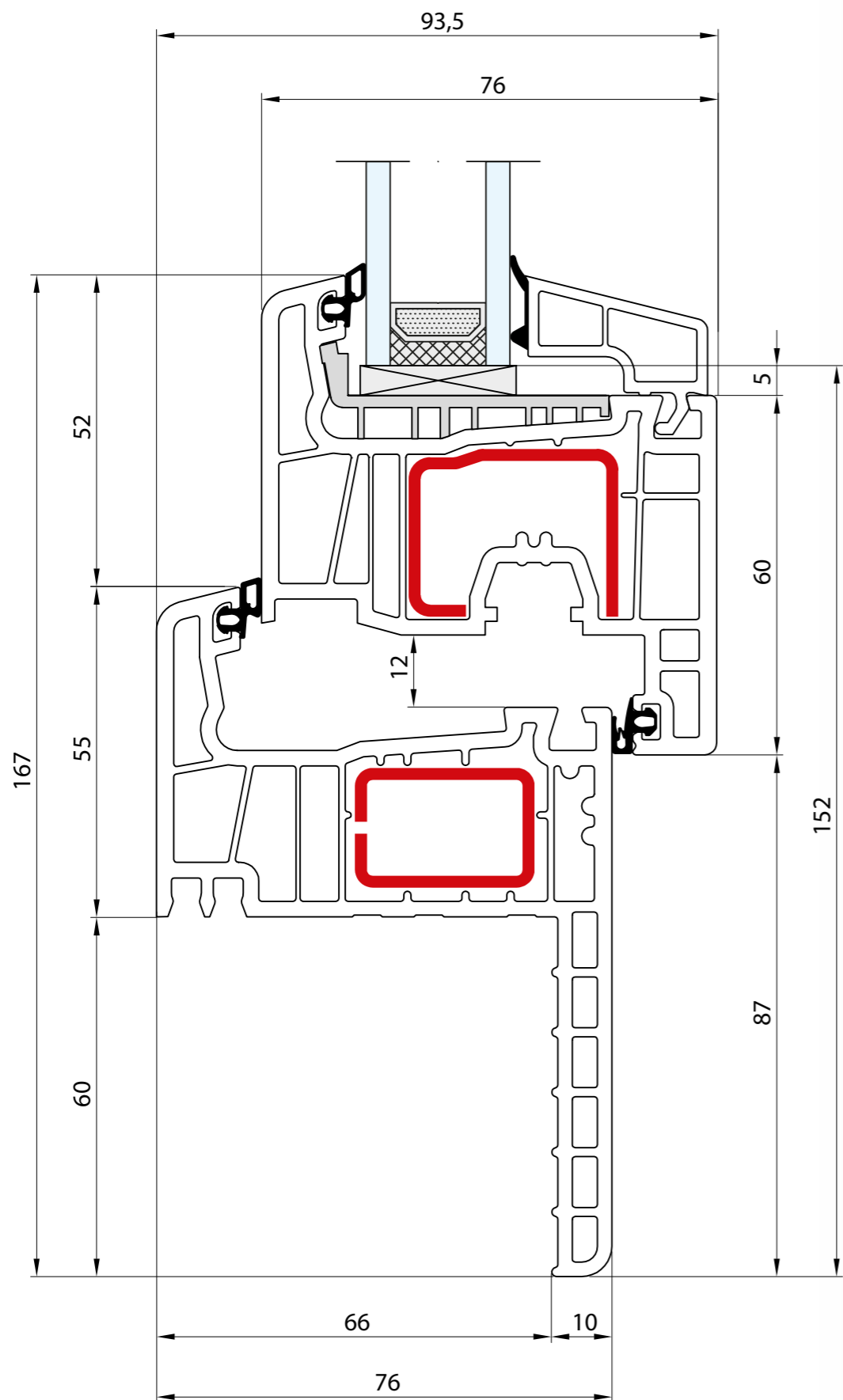

- RENOWACJA - Pletwa: 60 mm · Rama: 55 mm · Skrzydło: 80 mm
- RÉNOVATION - Lip: 60 mm · Dormant: 55 mm · Vantail: 80 mm
- RENOVATION - Strip: 60 mm · Frame: 55 mm · Sash: 80 mm
- RENOVIERUNG - Flosse: 60 mm · Rahmen: 55 mm · Flügel: 80 mm
- RINNOVAZIONE - Aletta da: 60 mm · Telaio: 55 mm · Anta: 80 mm

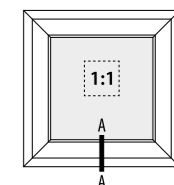
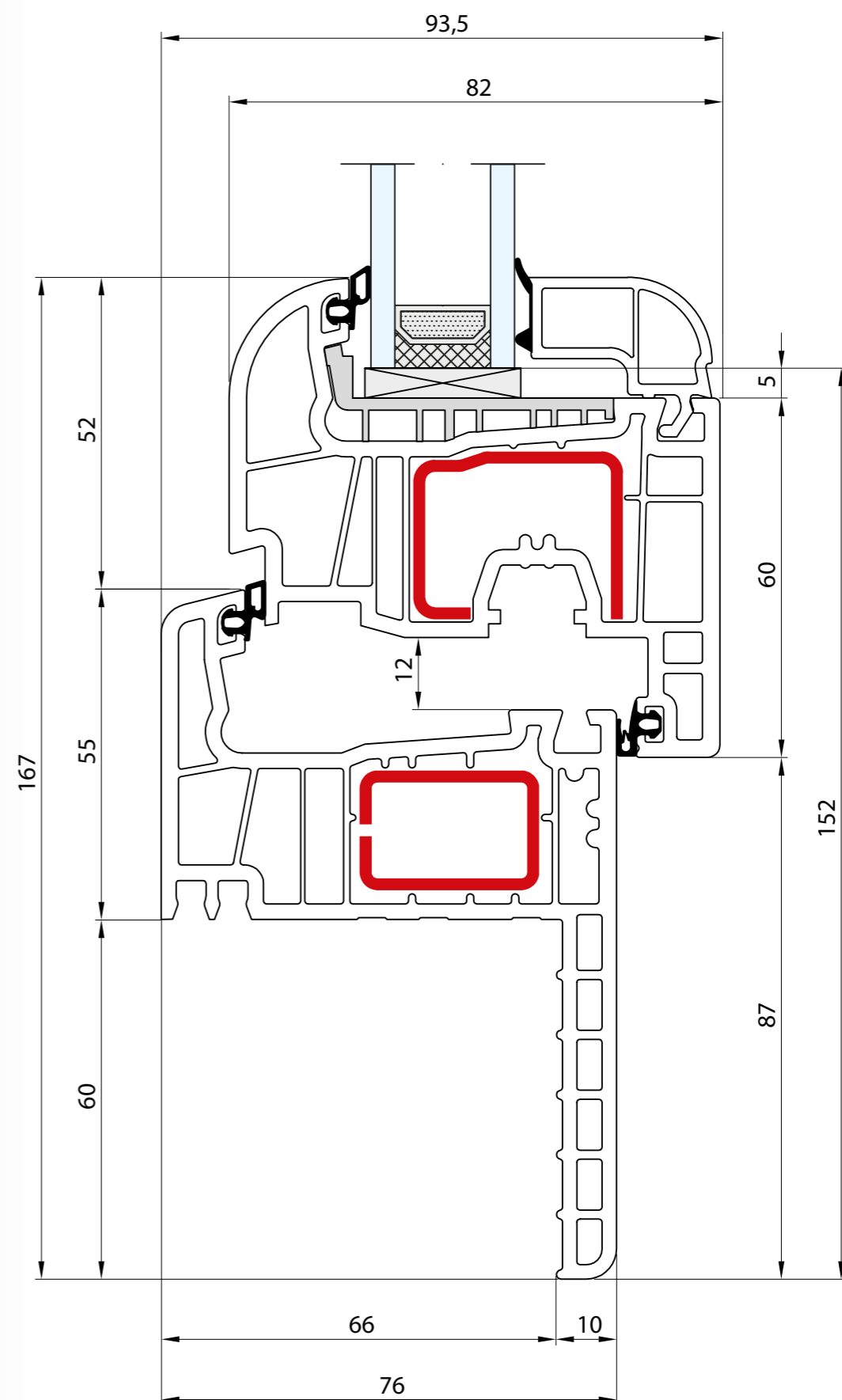

- RENOWACJA - Pletwa: 60 mm · Rama: 55 mm · Skrzydło: 80 mm
- RÉNOVATION - Lip: 60 mm · Dormant: 55 mm · Vantail: 80 mm
- RENOVATION - Strip: 60 mm · Frame: 55 mm · Sash: 80 mm
- RENOVIERUNG - Flosse: 60 mm · Rahmen: 55 mm · Flügel: 80 mm
- RINNOVAZIONE - Aletta da: 60 mm · Telaio: 55 mm · Anta: 80 mm

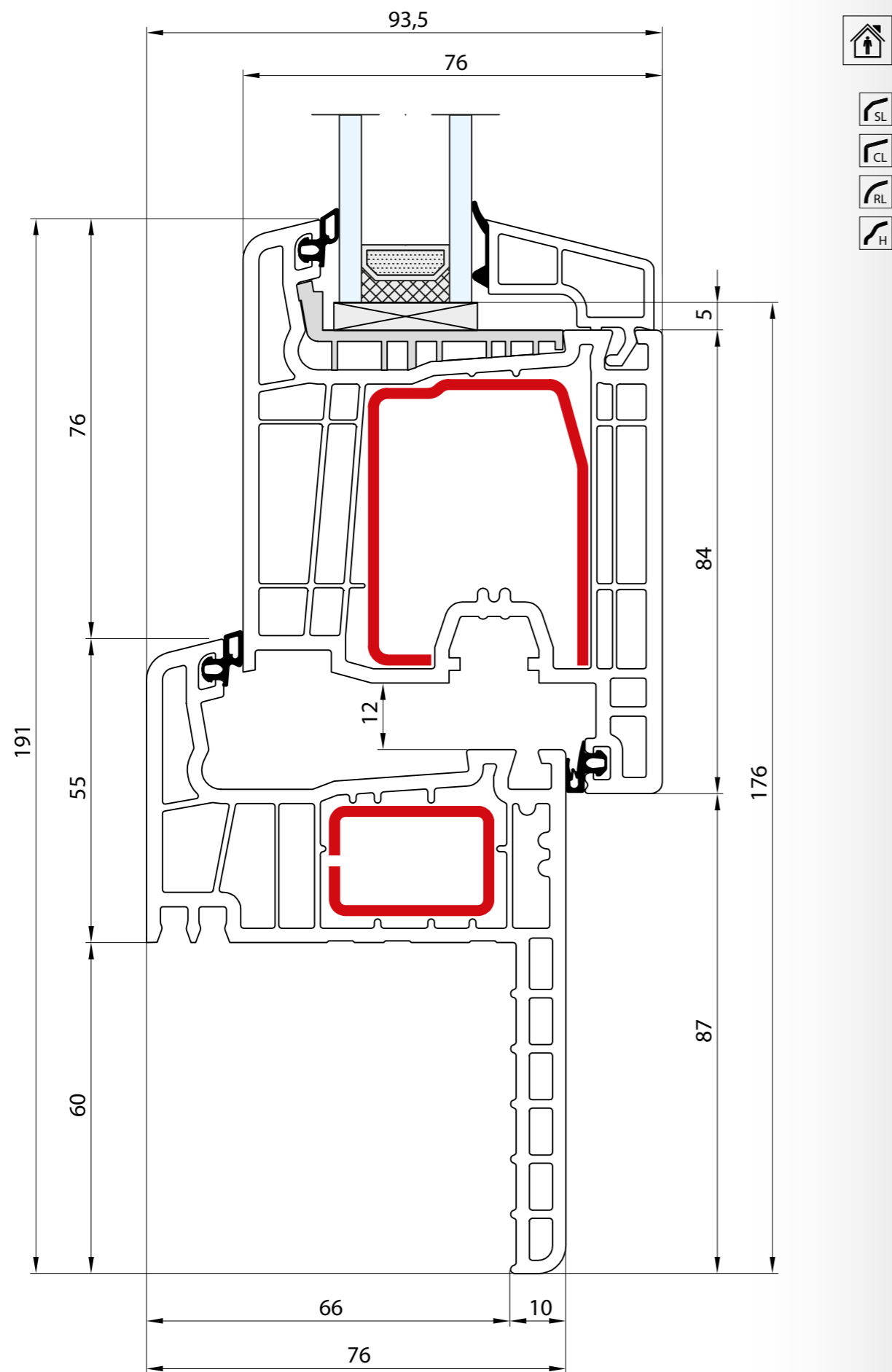

- RENOWACJA - Pletwa: 60 mm · Rama: 55 mm · Skrzydło: 104 mm
- RÉNOVATION - Lip: 60 mm · Dormant: 55 mm · Vantail: 104 mm
- RENOVATION - Strip: 60 mm · Frame: 55 mm · Sash: 104 mm
- RENOVIERUNG - Flosse: 60 mm · Rahmen: 55 mm · Flügel: 104 mm
- RINNOVAZIONE - Aletta da: 60 mm · Telaio: 55 mm · Anta: 104 mm

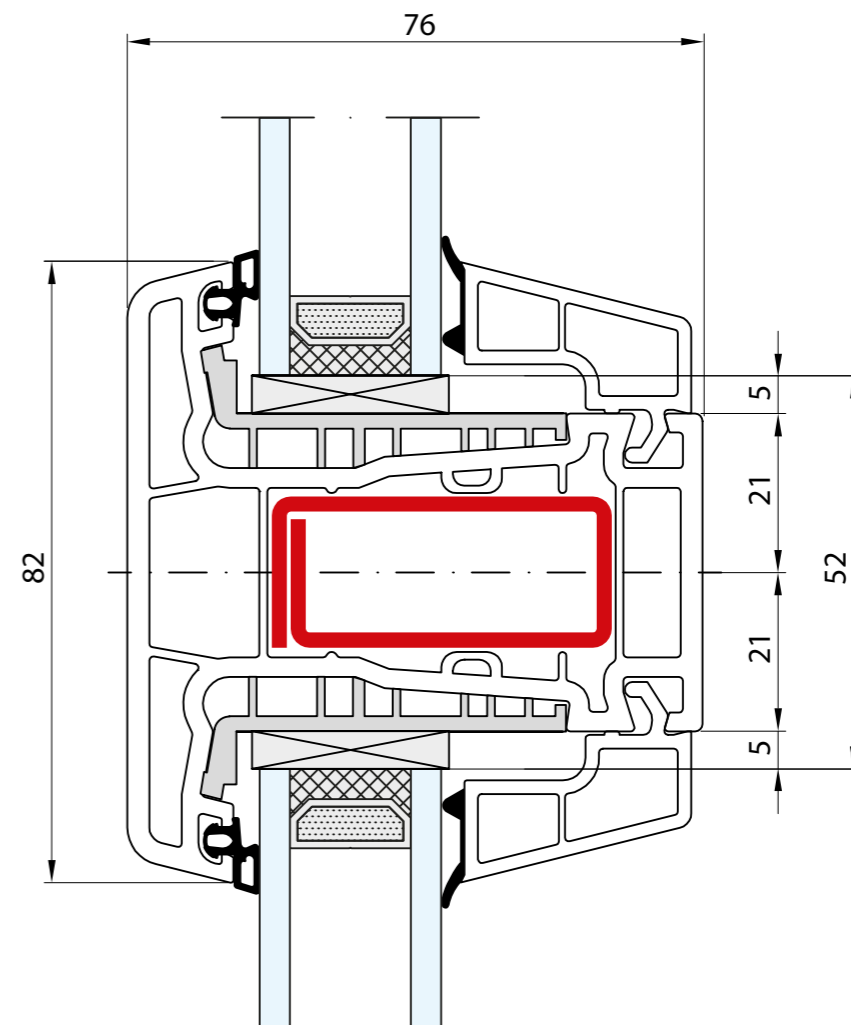
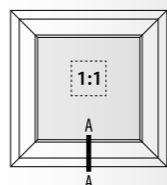

- Słupek stały: 82 mm
- Meneau fixe: 82 mm
- Fix post: 82 mm
- Festem Pfahl: 82 mm
- Montante fisso: 82 mm

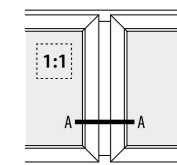

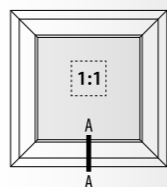
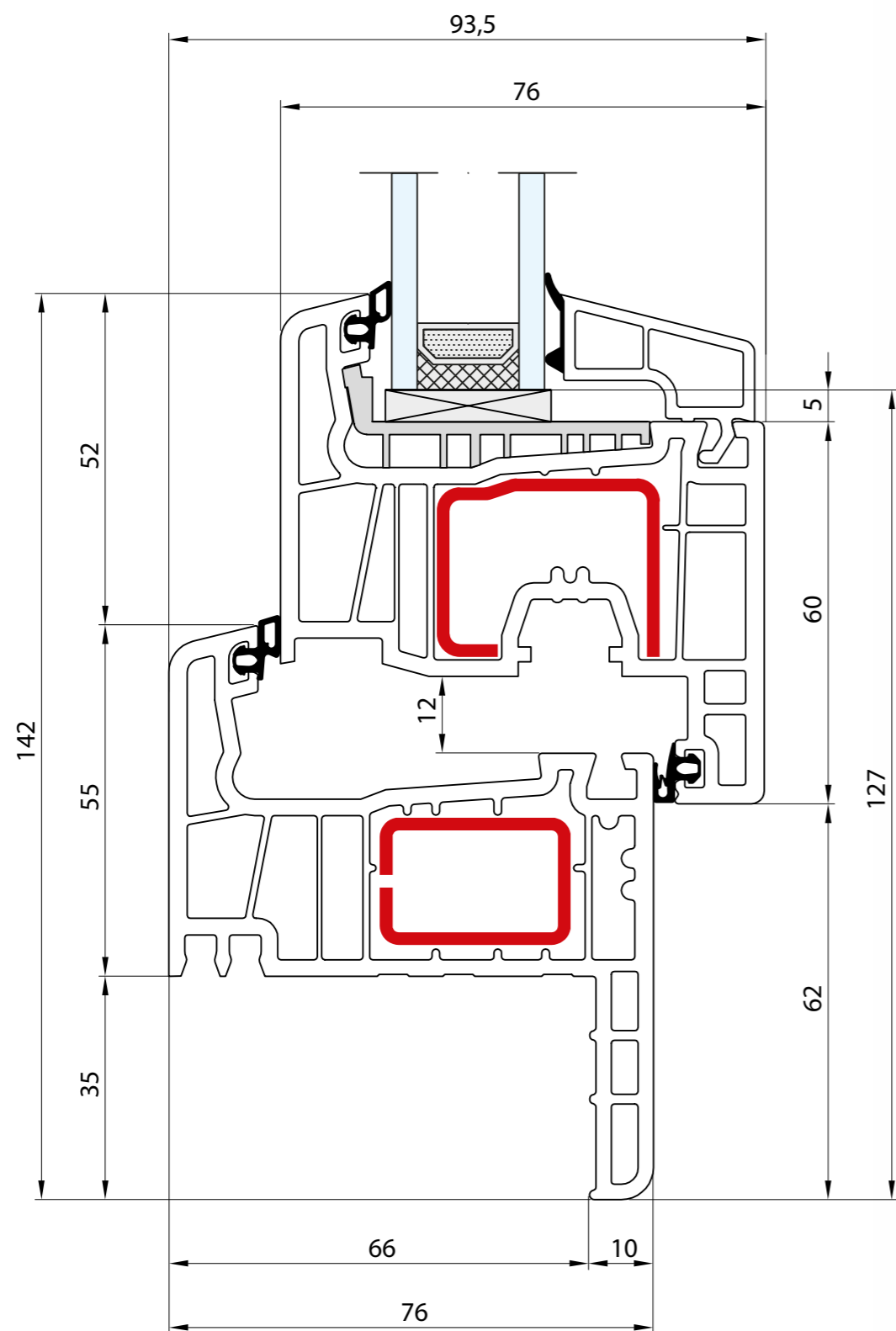

- RENOWACJA - Pletwa: 35 mm · Rama: 55 mm · Skrzydło: 80 mm
- RÉNOVATION - Lip: 35 mm · Dormant: 55 mm · Vantail: 80 mm
- RENOVATION - Strip: 35 mm · Frame: 55 mm · Sash: 80 mm
- RENOVIERUNG - Flosse: 35 mm · Rahmen: 55 mm · Flügel: 80 mm
- RINNOVAZIONE - Aletta da: 35 mm · Telaio: 55 mm · Anta: 80 mm

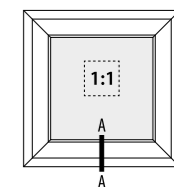
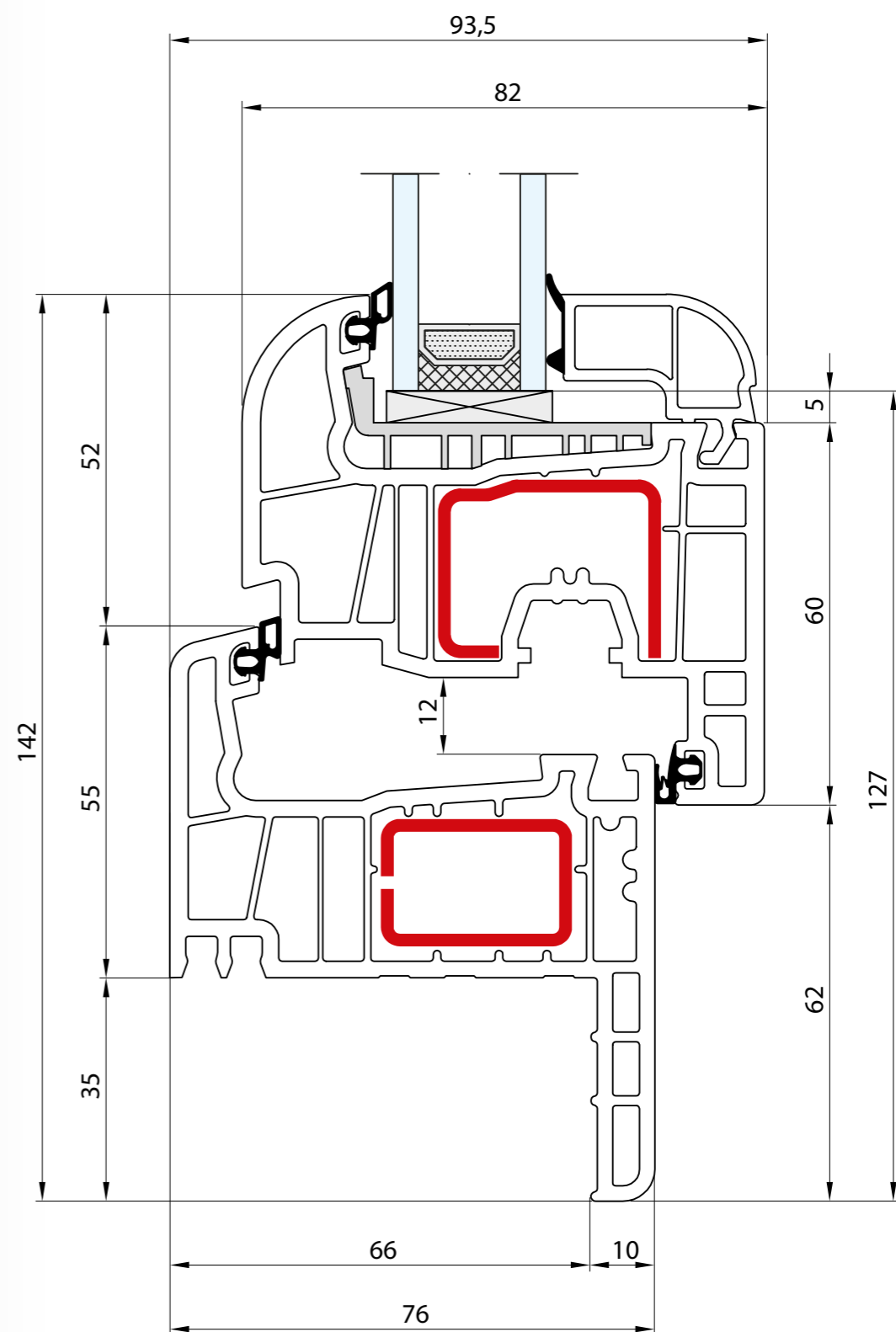

- RENOWACJA - Pletwa: 35 mm · Rama: 55 mm · Skrzydło: 80 mm
- RÉNOVATION - Lip: 35 mm · Dormant: 55 mm · Vantail: 80 mm
- RENOVATION - Strip: 35 mm · Frame: 55 mm · Sash: 80 mm
- RENOVIERUNG - Flosse: 35 mm · Rahmen: 55 mm · Flügel: 80 mm
- RINNOVAZIONE - Aletta da: 35 mm · Telaio: 55 mm · Anta: 80 mm

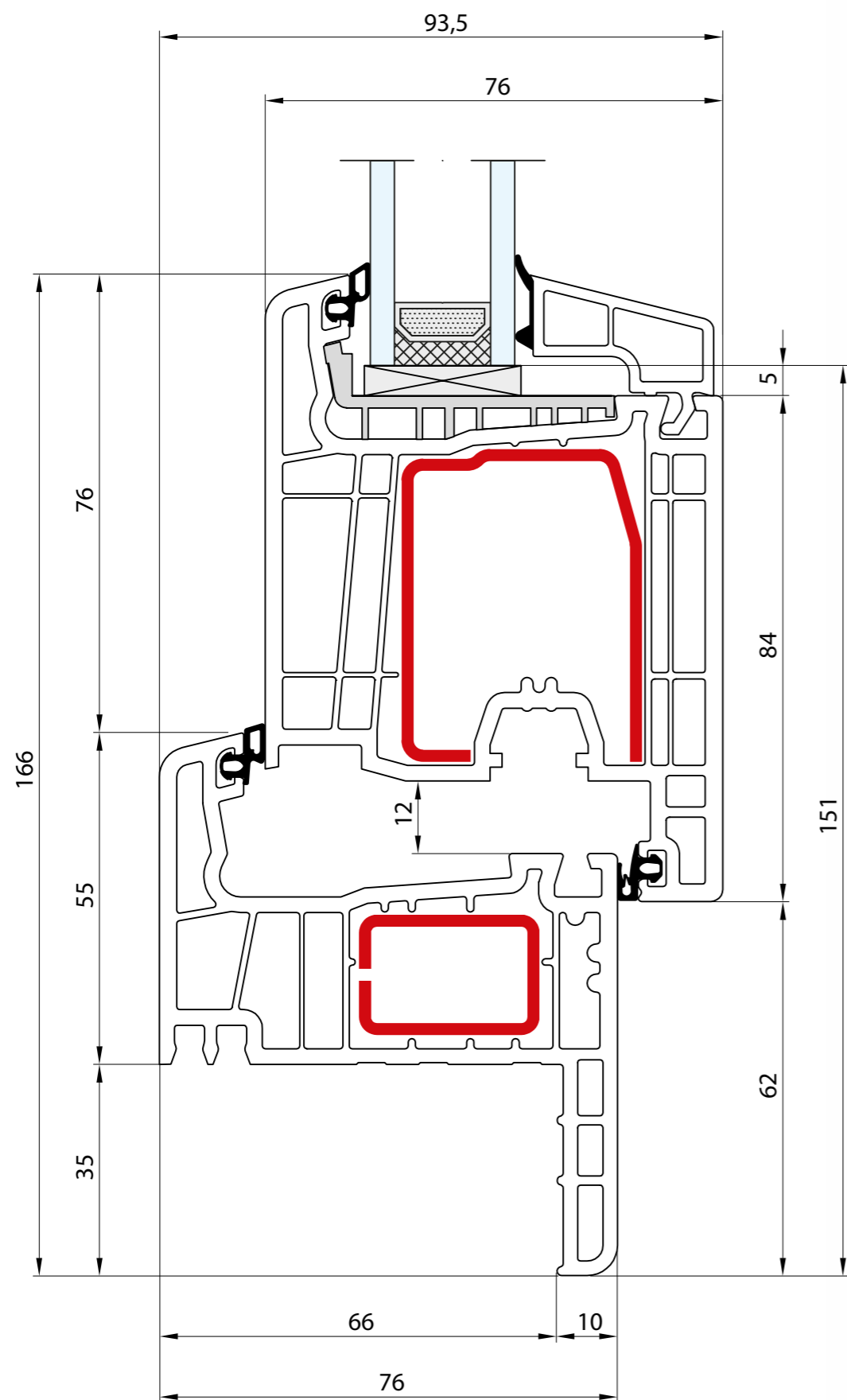

- RENOWACJA - Pletwa: 35 mm · Rama: 55 mm · Skrzydło: 104 mm
- RÉNOVATION - Lip: 35 mm · Dormant: 55 mm · Vantail: 104 mm
- RENOVATION - Strip: 35 mm · Frame: 55 mm · Sash: 104 mm
- RENOVIERUNG - Flosse: 35 mm · Rahmen: 55 mm · Flügel: 104 mm
- RINNOVAZIONE - Aletta da: 35 mm · Telaio: 55 mm · Anta: 104 mm

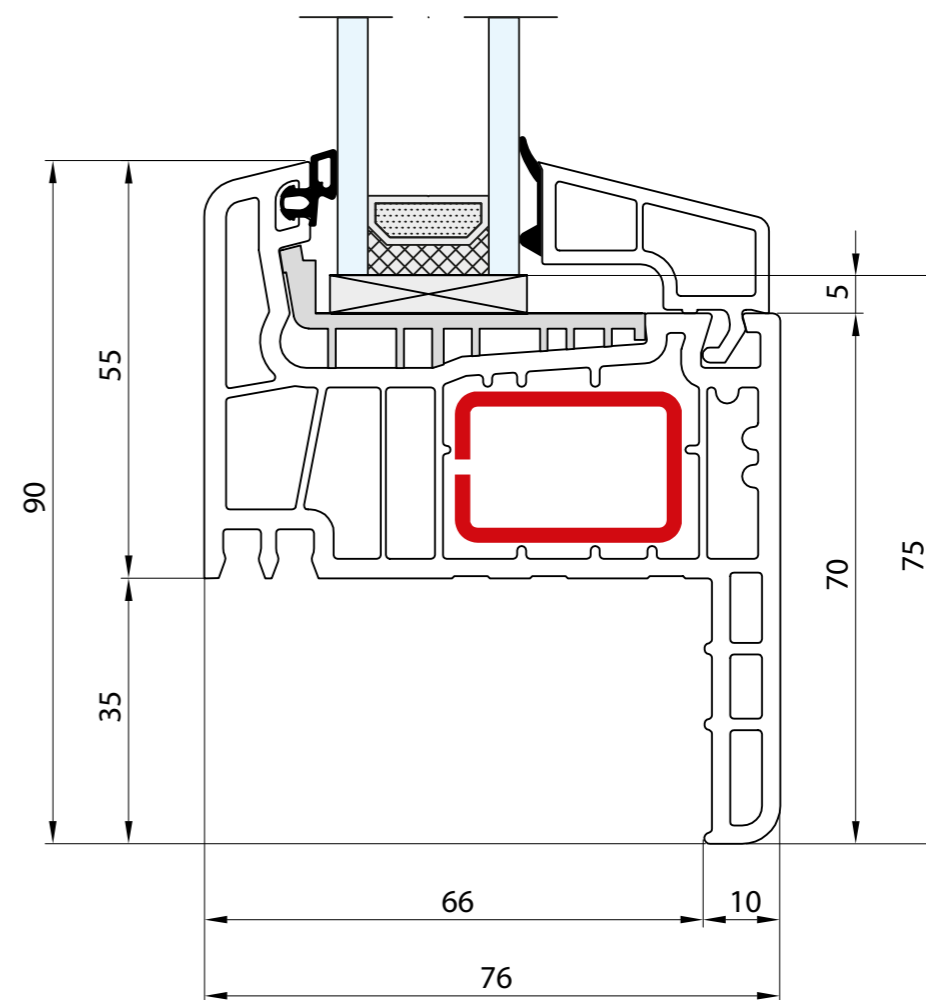
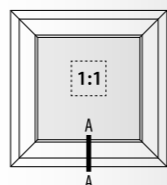

- RENOWACJA - Pletwa: 35 mm · Rama: 55 mm
- RÉNOVATION - Lip: 35 mm · Dormant: 55 mm
- RENOVATION - Strip: 35 mm · Frame: 55 mm
- RENOVIERUNG - Flosse: 35 mm · Rahmen: 55 mm
- RINNOVAZIONE - Aletta da: 35 mm · Telaio: 55 mm

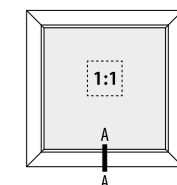

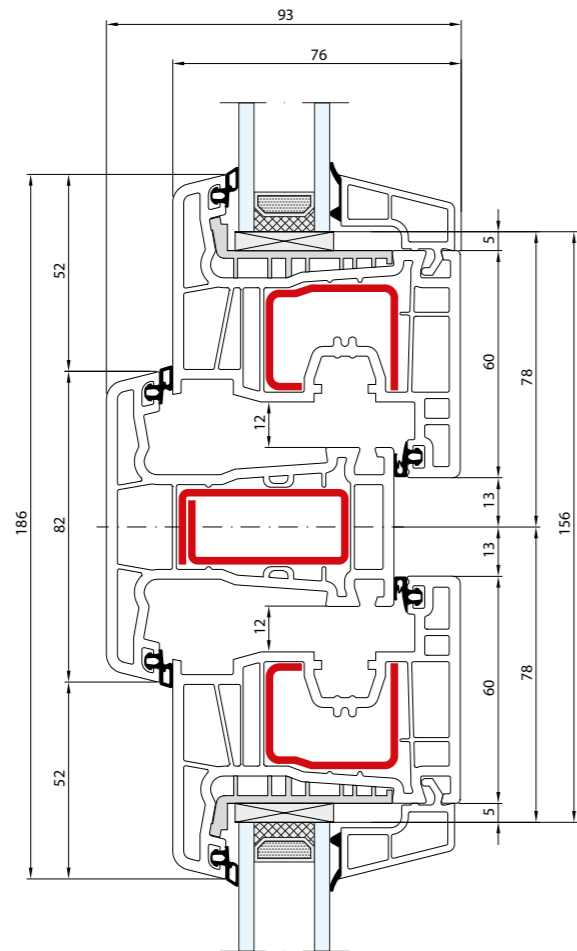

- Słupek stały: 82 mm · Skrzydło: 80 mm
- Meneau fixe: 82 mm · Vantail: 80 mm
- Fix post: 82 mm · Sash: 80 mm
- Festem Pfahl: 82 mm · Flügel: 80 mm
- Montante fisso: 82 mm · Anta: 80 mm

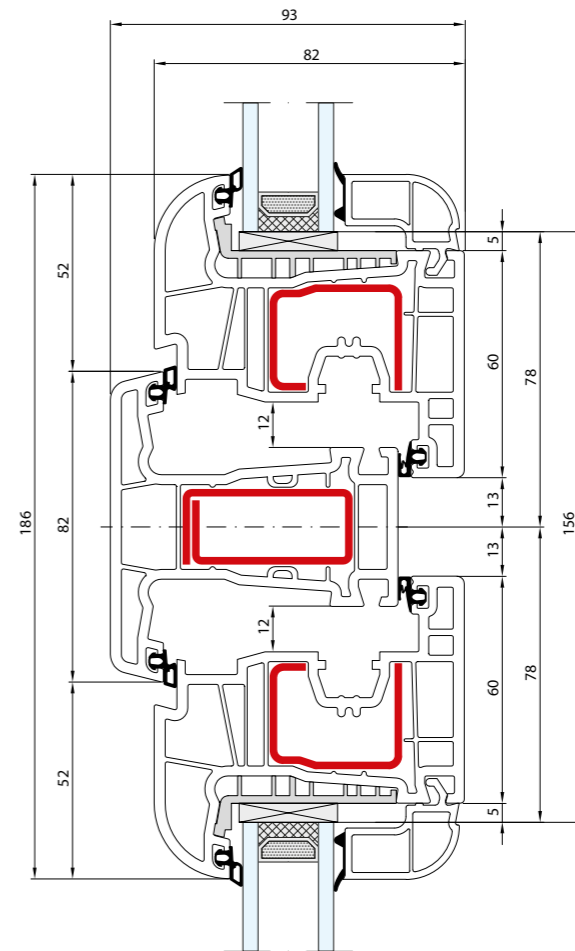
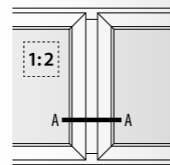

- Słupek stały: 82 mm · Skrzydło: 80 mm
- Meneau fixe: 82 mm · Vantail: 80 mm
- Fix post: 82 mm · Sash: 80 mm
- Festem Pfahl: 82 mm · Flügel: 80 mm
- Montante fisso: 82 mm · Anta: 80 mm

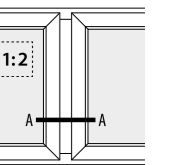

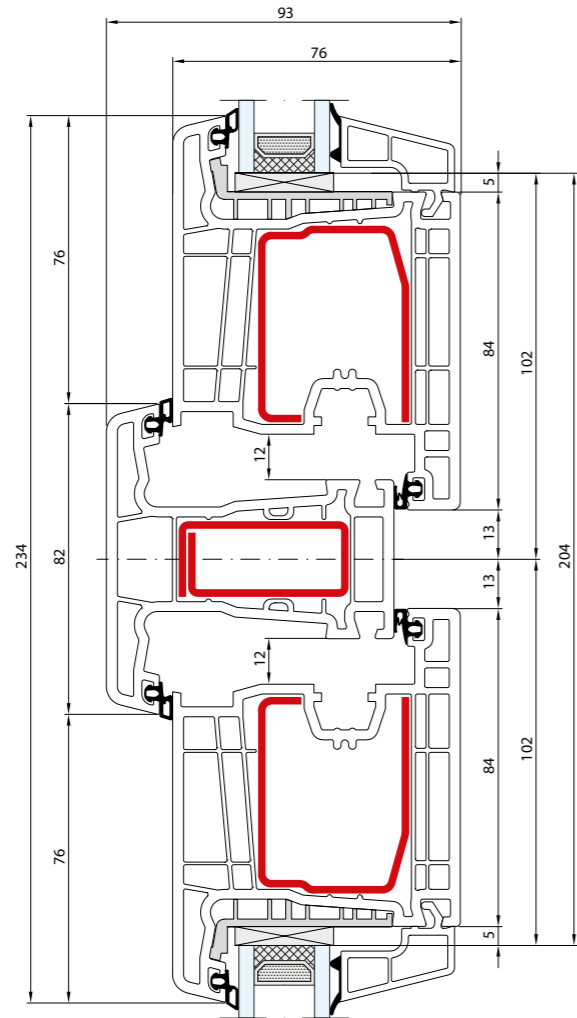

- Słupek stały: 82 mm · Skrzydło: 104 mm
- Meneau fixe: 82 mm · Vantail: 104 mm
- Fix post: 82 mm · Sash: 104 mm
- Festem Pfahl: 82 mm · Flügel: 104 mm
- Montante fisso: 82 mm · Anta: 104 mm

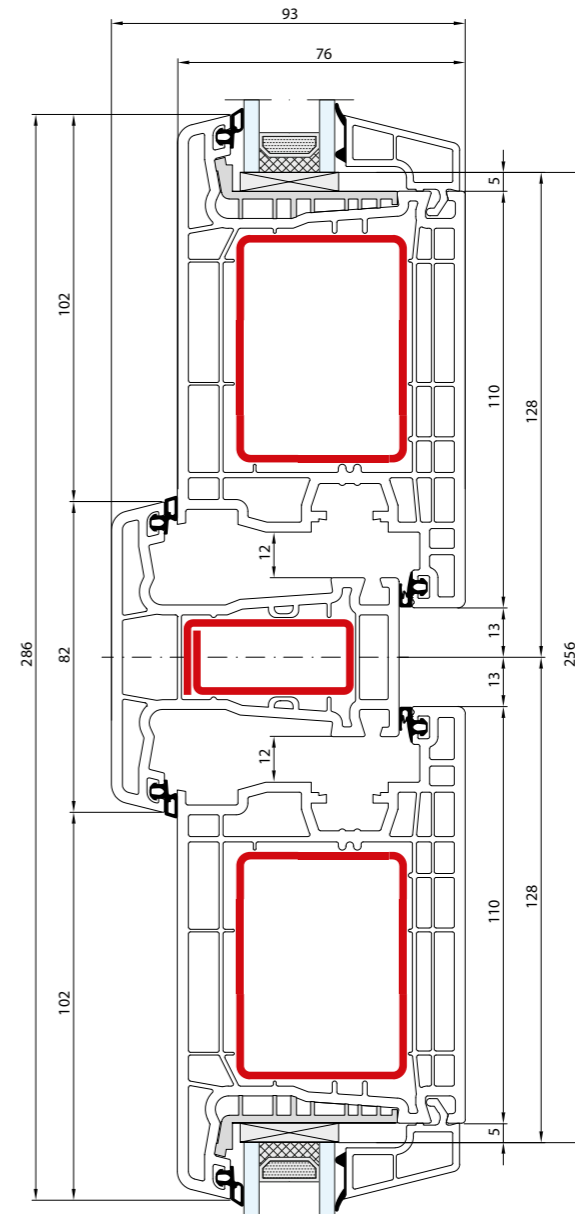
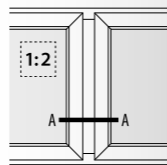

- Słupek stały: 82 mm · Skrzydło: 130 mm
- Meneau fixe: 82 mm · Vantail: 130 mm
- Fix post: 82 mm · Sash: 130 mm
- Festem Pfahl: 82 mm · Flügel: 130 mm
- Montante fisso: 82 mm · Anta: 130 mm

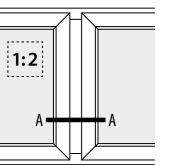

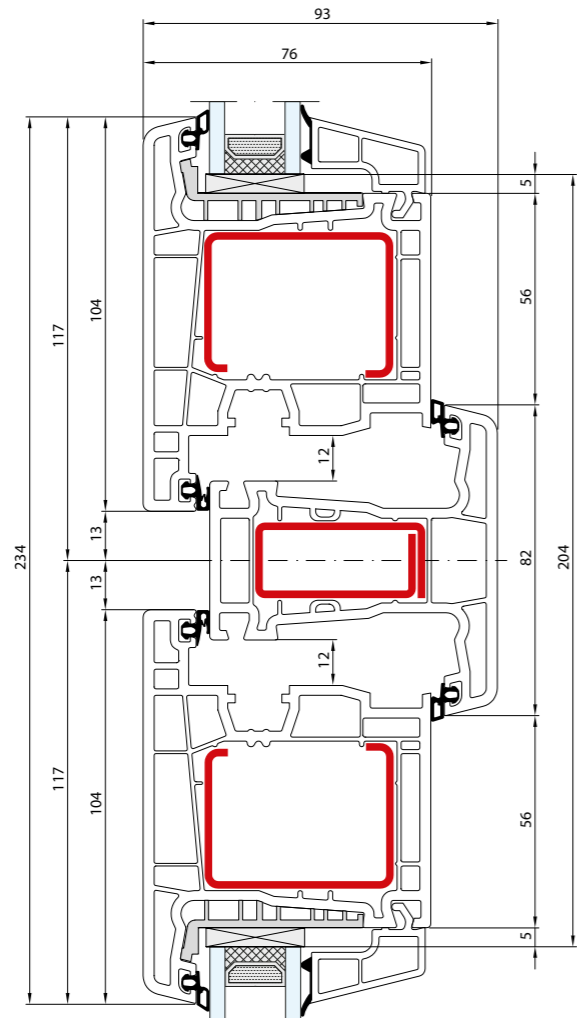

- Słupek stały: 82 mm · Skrzydło: 104 mm
- Meneau fixe: 82 mm · Vantail: 104 mm
- Fix post: 82 mm · Sash: 104 mm
- Festem Pfahl: 82 mm · Flügel: 104 mm
- Montante fisso: 82 mm · Anta: 104 mm

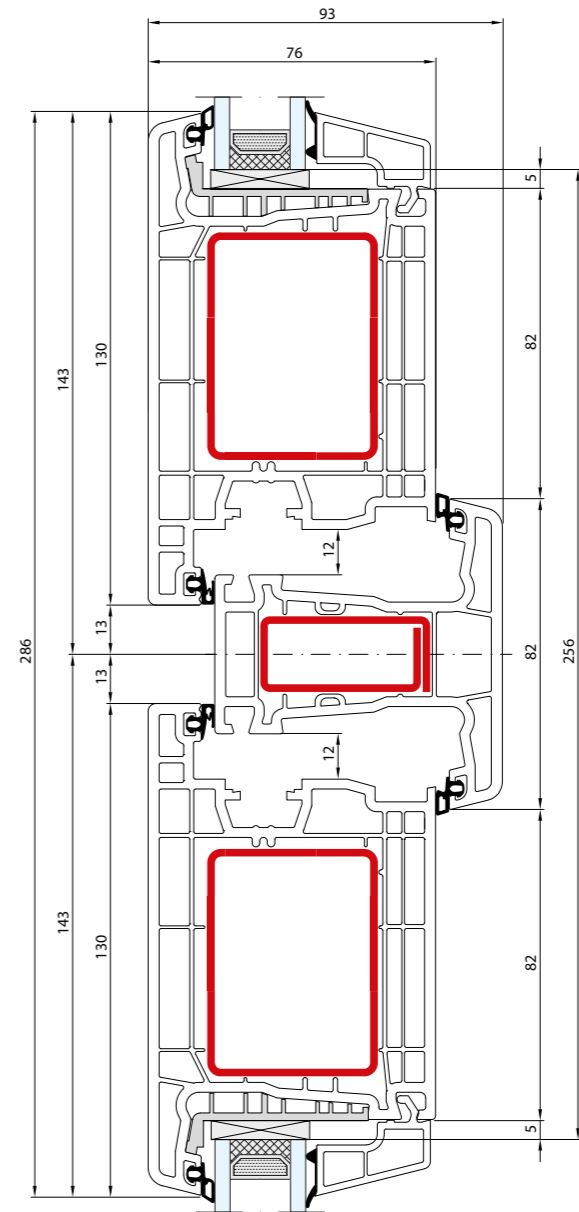
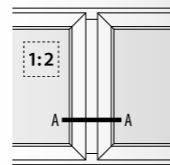

- Słupek stały: 82 mm · Skrzydło: 130 mm
- Meneau fixe: 82 mm · Vantail: 130 mm
- Fix post: 82 mm · Sash: 130 mm
- Festem Pfahl: 82 mm · Flügel: 130 mm
- Montante fisso: 82 mm · Anta: 130 mm

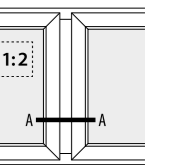

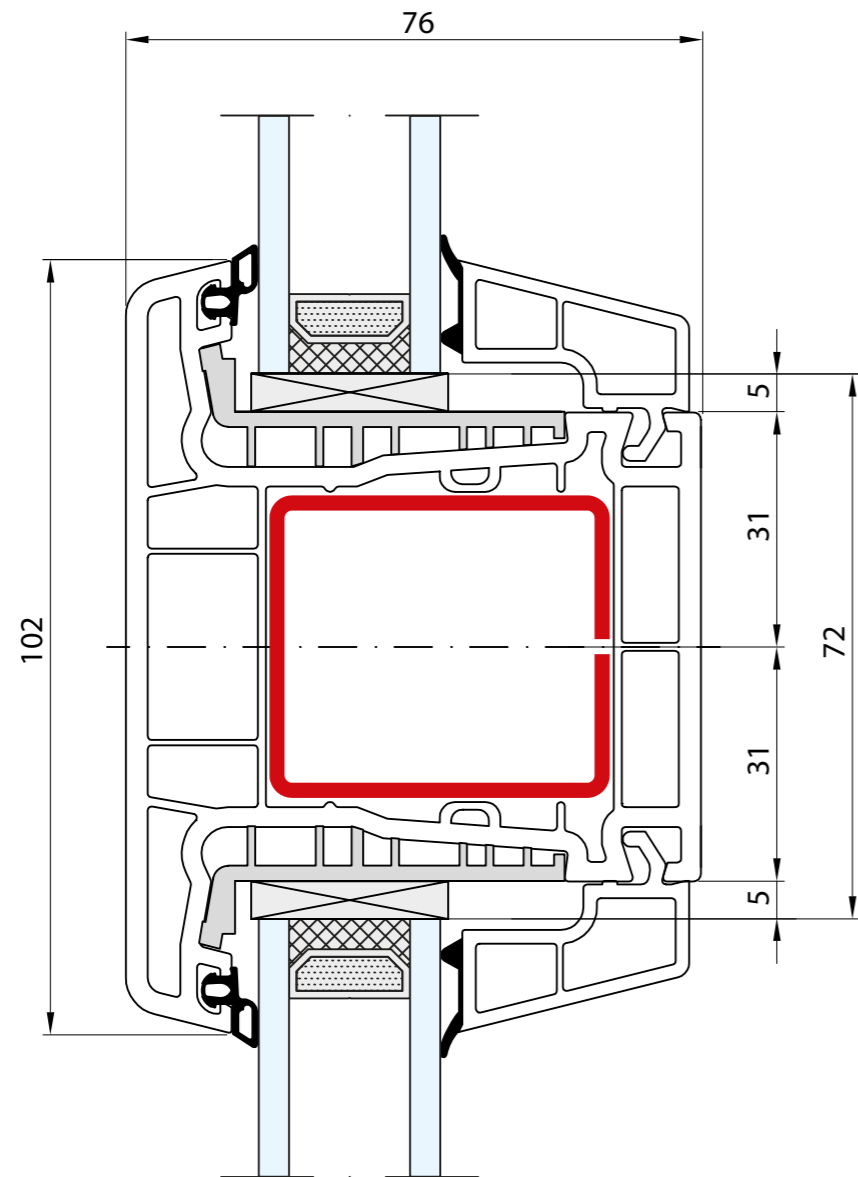

- Słupek stały: 102 mm
- Meneau fixe: 102 mm
- Fix post: 102 mm
- Festem Pfahl: 102 mm
- Montante fisso: 102 mm

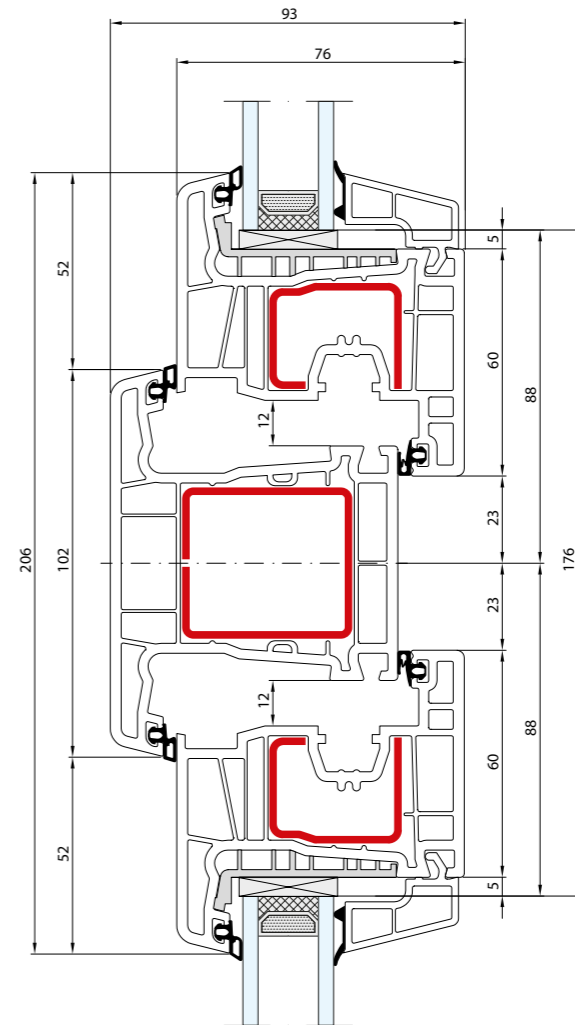
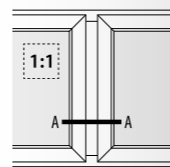

- Słupek stały: 102 mm · Skrzydło: 80 mm
- Meneau fixe: 102 mm · Vantail: 80 mm
- Fix post: 102 mm · Sash: 80 mm
- Festem Pfahl: 102 mm · Flügel: 80 mm
- Montante fisso: 102 mm · Anta: 80 mm

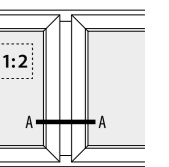

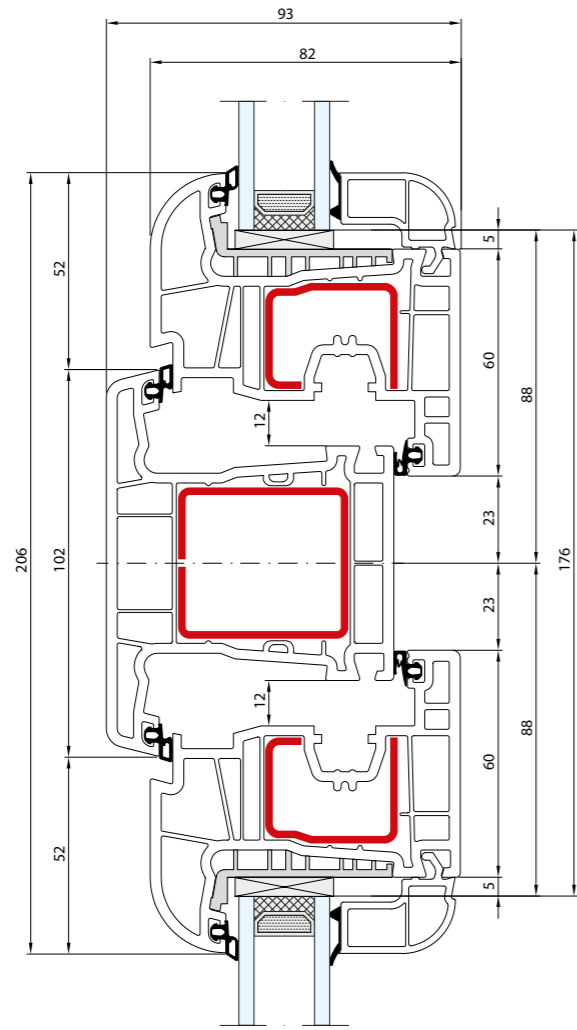

-  Słupek stały: 102 mm · Skrzydło: 80 mm
-  Meneau fixe: 102 mm · Vantail: 80 mm
-  Fix post: 102 mm · Sash: 80 mm
-  Festem Pfahl: 102 mm · Flügel: 80 mm
-  Montante fisso: 102 mm · Anta: 80 mm

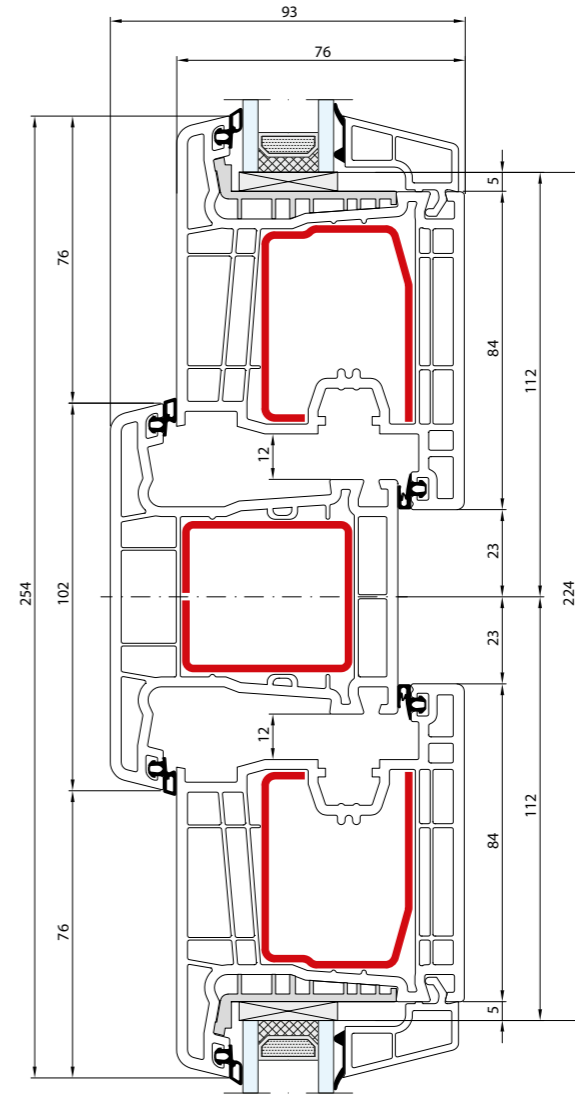
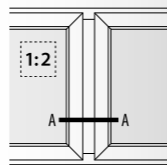

-  Słupek stały: 102 mm · Skrzydło: 104 mm
-  Meneau fixe: 102 mm · Vantail: 104 mm
-  Fix post: 102 mm · Sash: 104 mm
-  Festem Pfahl: 102 mm · Flügel: 104 mm
-  Montante fisso: 102 mm · Anta: 104 mm

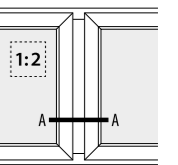

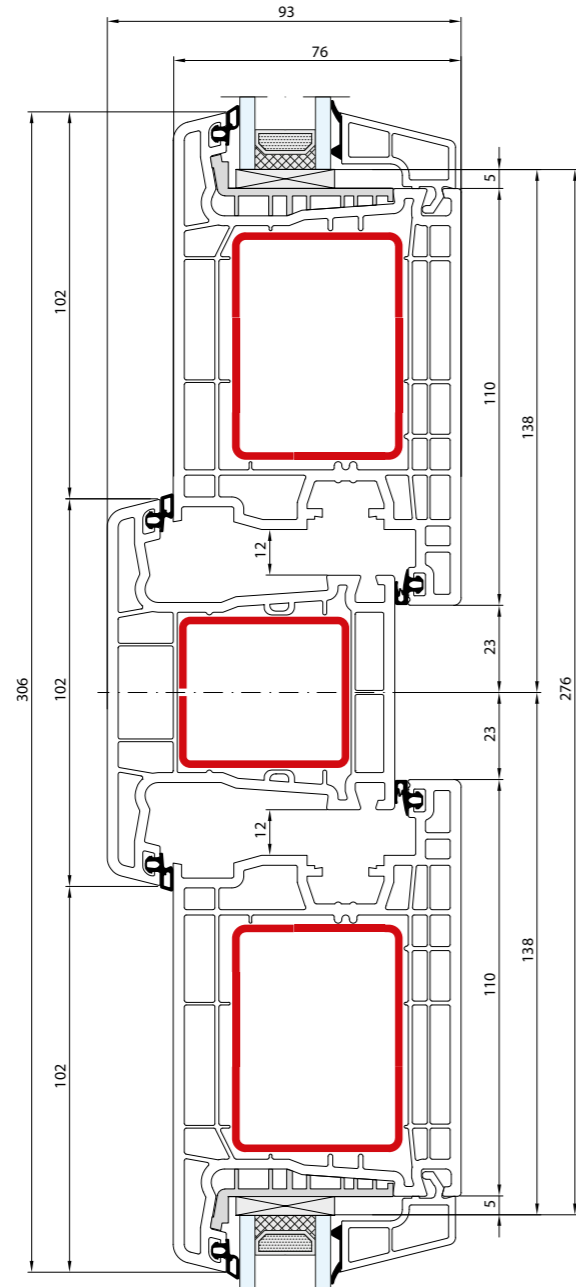

- Słupek stały: 102 mm · Skrzydło: 130 mm
- Meneau fixe: 102 mm · Vantail: 130 mm
- Fix post: 102 mm · Sash: 130 mm
- Festem Pfahl: 102 mm · Flügel: 130 mm
- Montante fisso: 102 mm · Anta: 130 mm

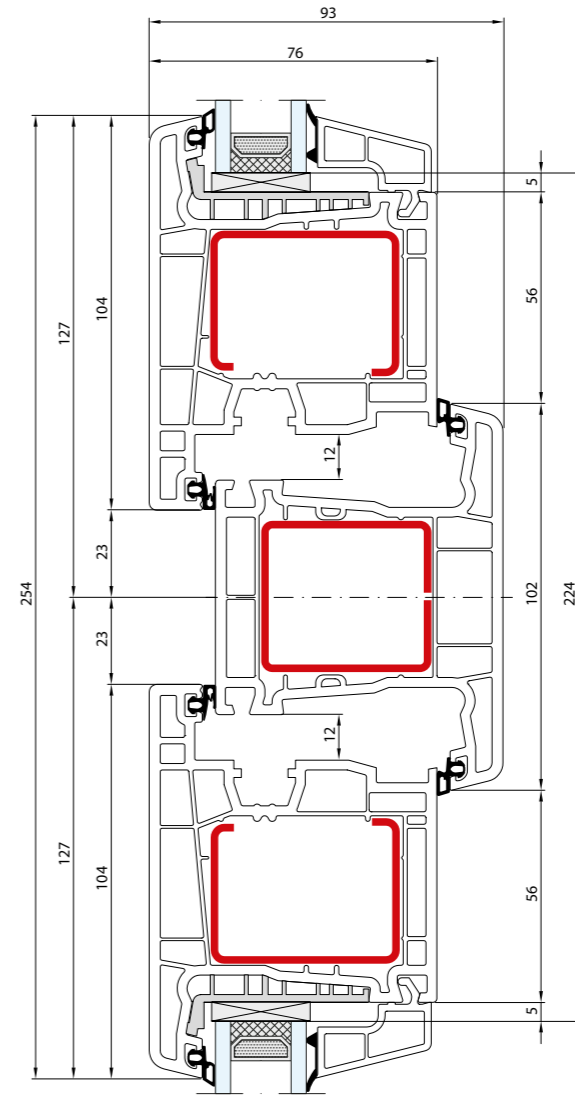
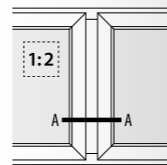

- Słupek stały: 102 mm · Skrzydło: 104 mm
- Meneau fixe: 102 mm · Vantail: 104 mm
- Fix post: 102 mm · Sash: 104 mm
- Festem Pfahl: 102 mm · Flügel: 104 mm
- Montante fisso: 102 mm · Anta: 104 mm

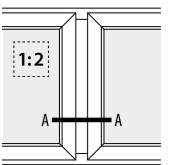

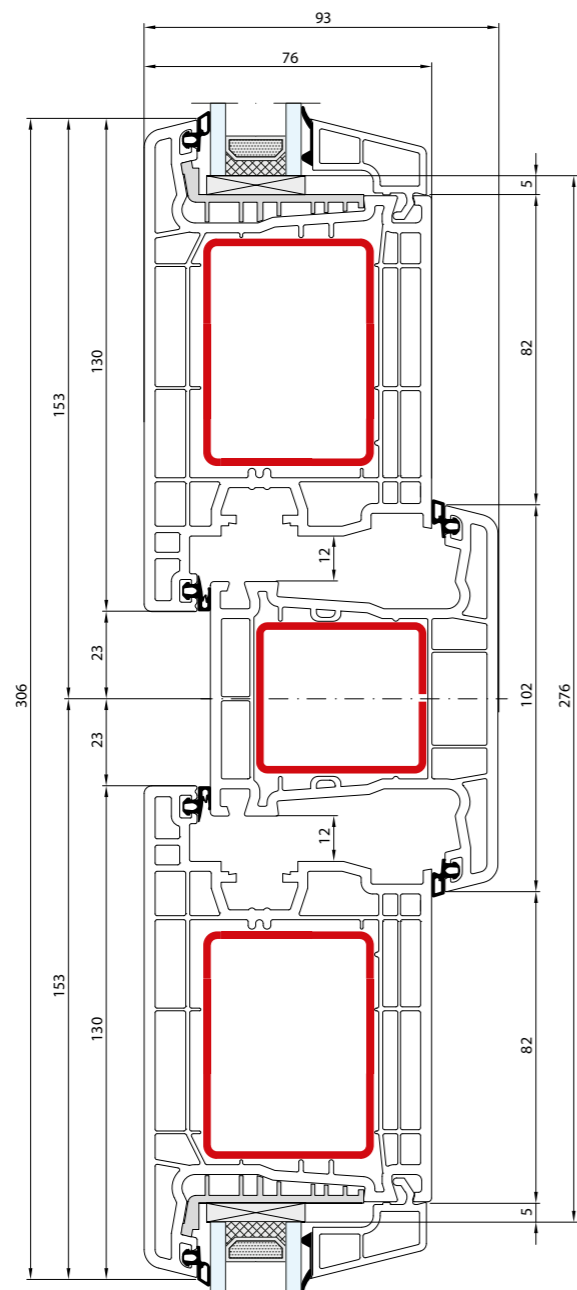

- Słupek stały: 102 mm · Skrzydło: 130 mm
- Meneau fixe: 102 mm · Vantail: 130 mm
- Fix post: 102 mm · Sash: 130 mm
- Festem Pfahl: 102 mm · Flügel: 130 mm
- Montante fisso: 102 mm · Anta: 130 mm

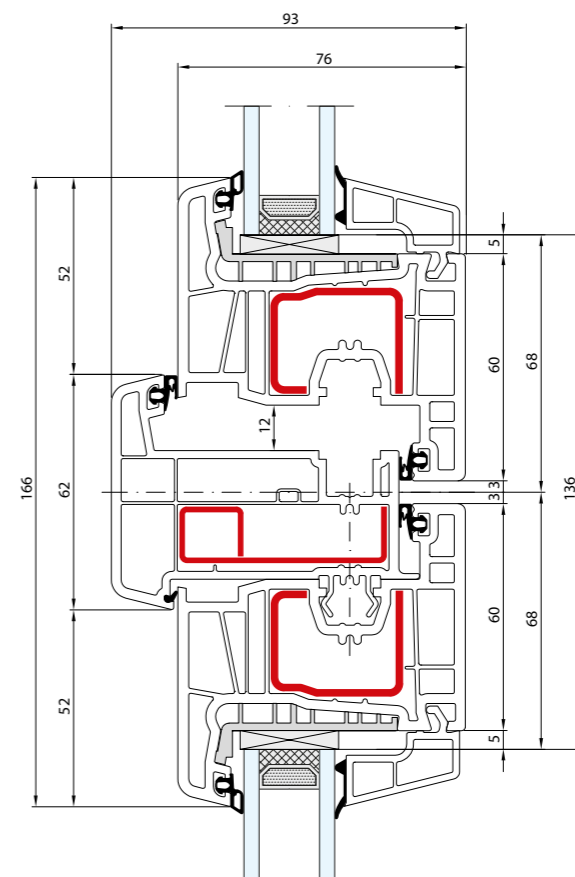
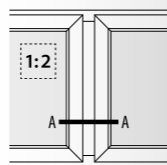

- Słupek ruchomy: 62 mm · Skrzydło: 80 mm
- Meneau mobile: 62 mm · Vantail: 80 mm
- Movable post: 62 mm · Sash: 80 mm
- Stulp: 62 mm · Flügel: 80 mm
- Montante mobile: 62 mm · Anta: 80 mm

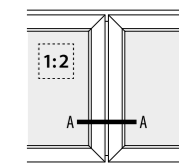

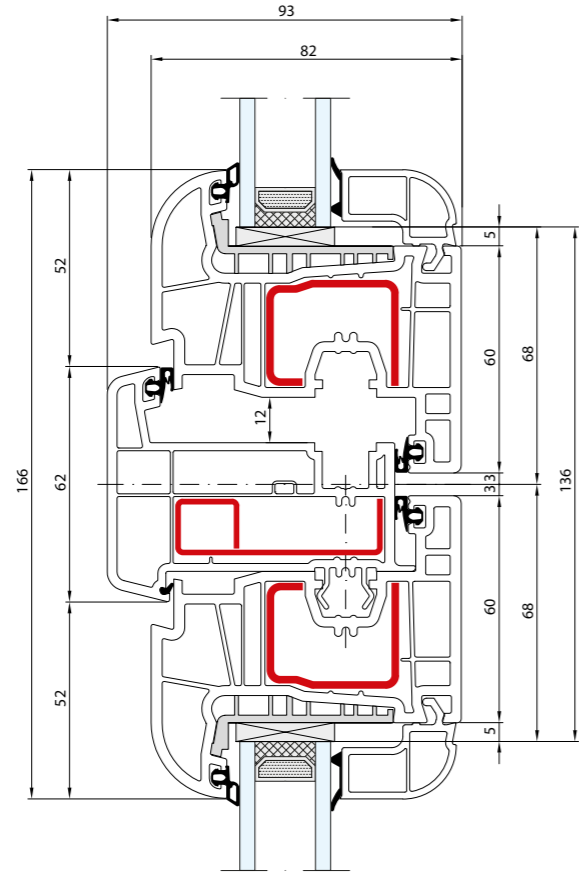

- Słupek ruchomy: 62 mm · Skrzydło: 80 mm
- Meneau mobile: 62 mm · Vantail: 80 mm
- Movable post: 62 mm · Sash: 80 mm
- Stulp: 62 mm · Flügel: 80 mm
- Montante mobile: 62 mm · Anta: 80 mm

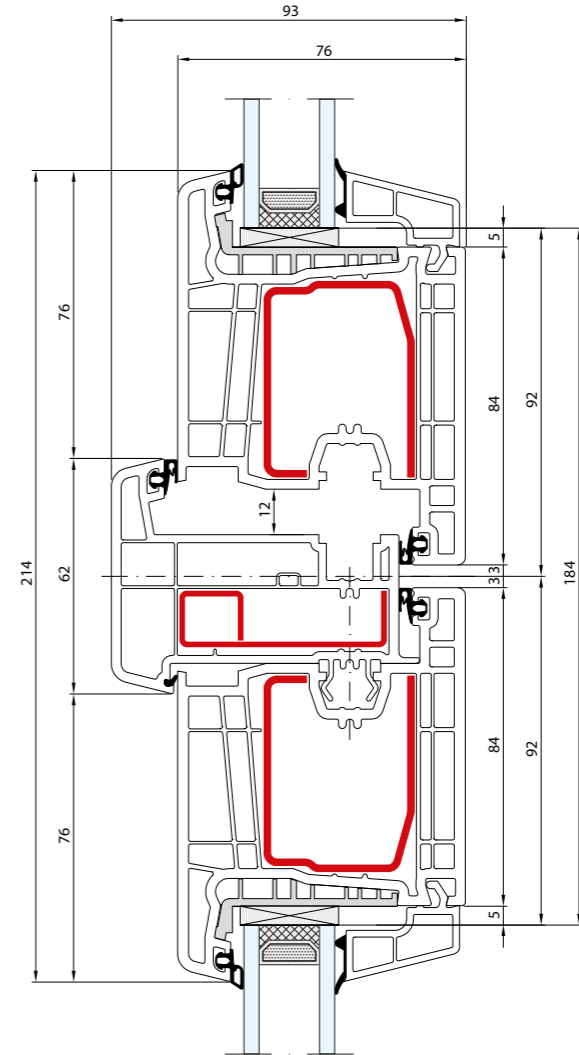
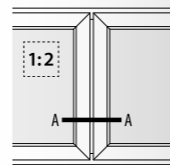

- Słupek ruchomy: 62 mm · Skrzydło: 104 mm
- Meneau mobile: 62 mm · Vantail: 104 mm
- Movable post: 62 mm · Sash: 104 mm
- Stulp: 62 mm · Flügel: 104 mm
- Montante mobile: 62 mm · Anta: 104 mm

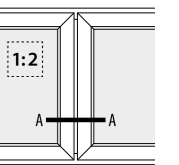

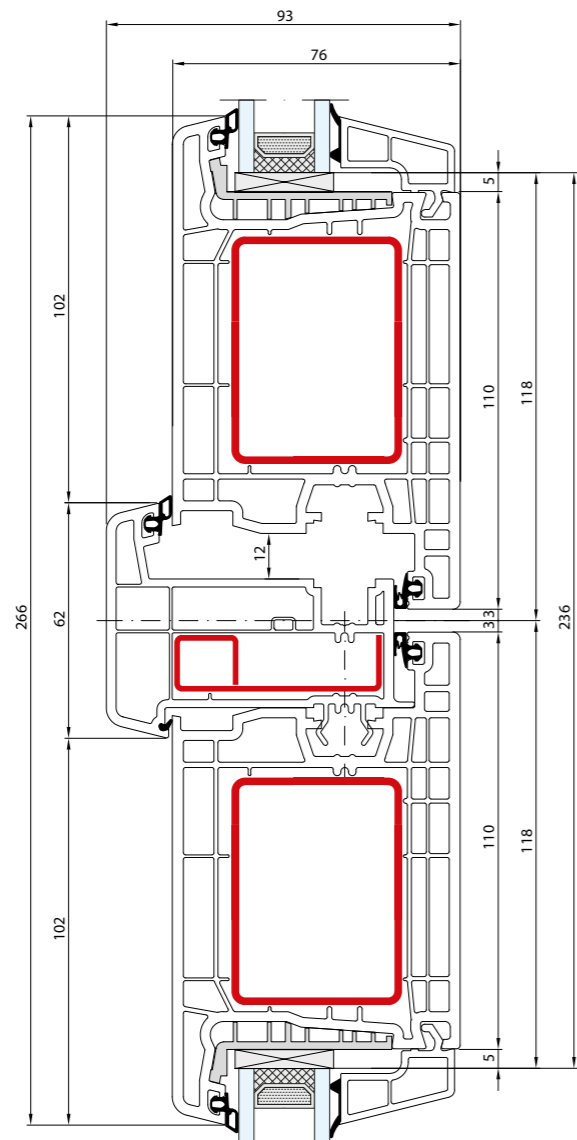

- Słupek ruchomy: 62 mm · Skrzydło: 130 mm
- Meneau mobile: 62 mm · Vantail: 130 mm
- Movable post: 62 mm · Sash: 130 mm
- Stulp: 62 mm · Flügel: 130 mm
- Montante mobile: 62 mm · Anta: 130 mm

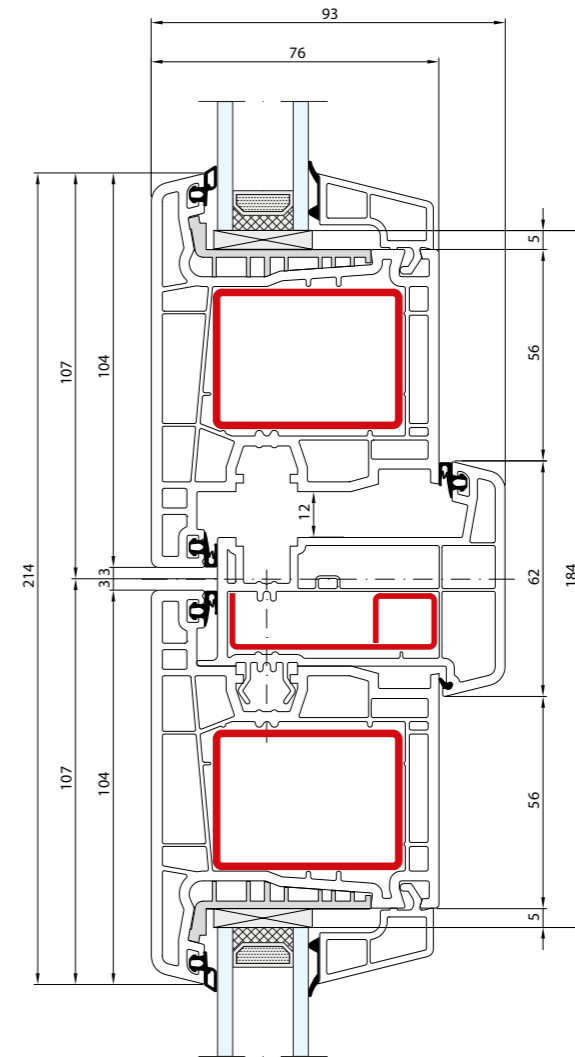
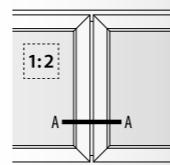

- Słupek ruchomy: 62 mm · Skrzydło: 104 mm
- Meneau mobile: 62 mm · Vantail: 104 mm
- Movable post: 62 mm · Sash: 104 mm
- Stulp: 62 mm · Flügel: 104 mm
- Montante mobile: 62 mm · Anta: 104 mm

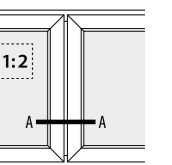

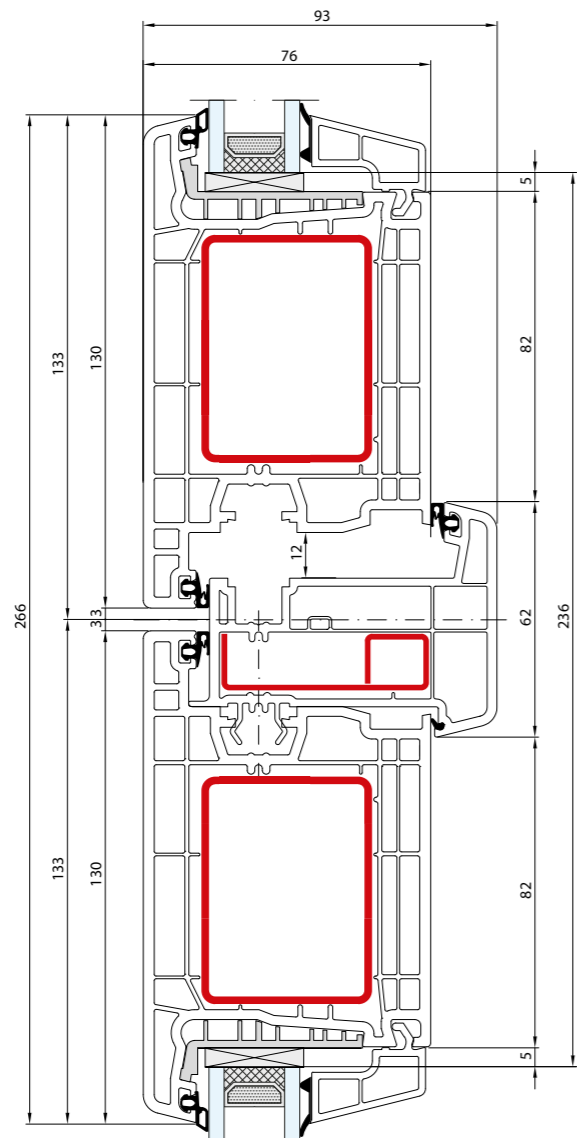

- Słupek ruchomy: 62 mm · Skrzydło: 130 mm
- Meneau mobile: 62 mm · Vantail: 130 mm
- Movable post: 62 mm · Sash: 130 mm
- Stulp: 62 mm · Flügel: 130 mm
- Montante mobile: 62 mm · Anta: 130 mm

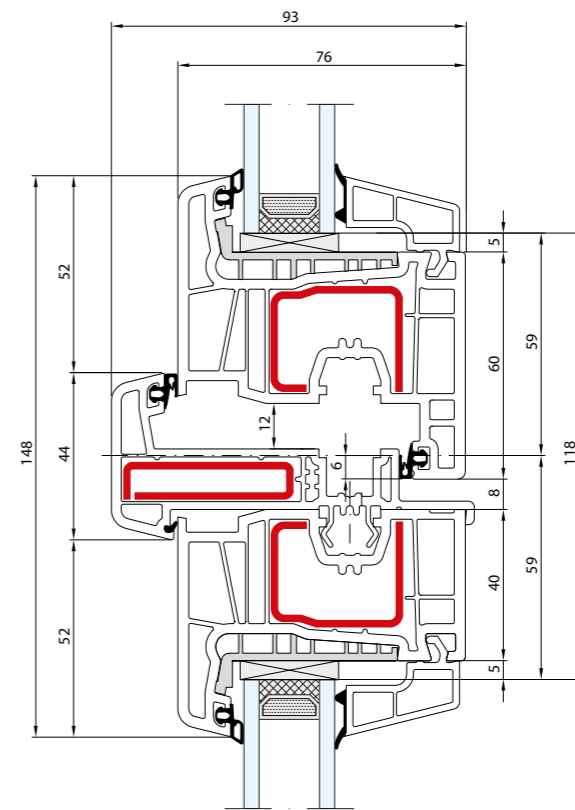
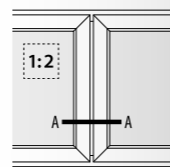

- Słupek ruchomy: 44 mm · Skrzydło: 80 mm / 60 mm
- Meneau mobile: 44 mm · Vantail: 80 mm / 60 mm
- Movable post: 44 mm · Sash: 80 mm / 60 mm
- Stulp: 44 mm · Flügel: 80 mm / 60 mm
- Montante mobile: 44 mm · Anta: 80 mm / 60 mm

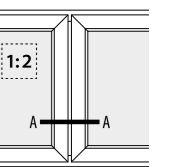

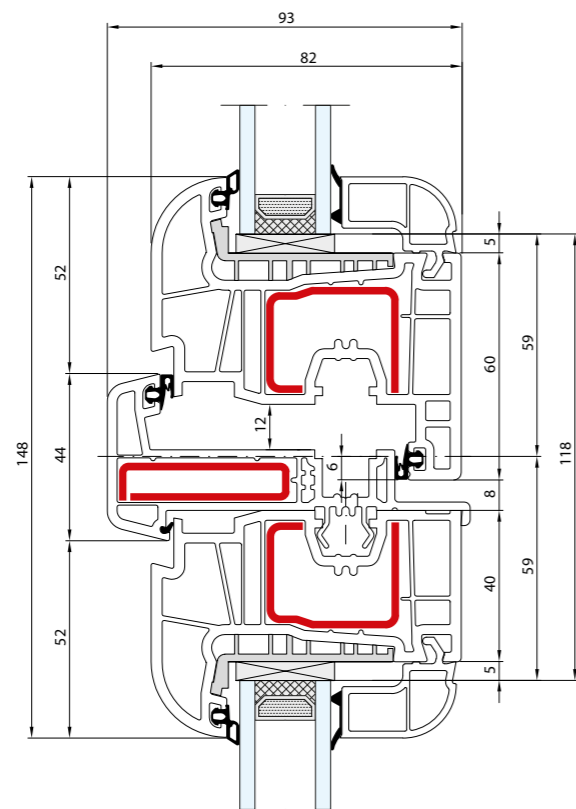

- Słupek ruchomy: 44 mm · Skrzydło: 80 mm / 60 mm
- Meneau mobile: 44 mm · Vantail: 80 mm / 60 mm
- Movable post: 44 mm · Sash: 80 mm / 60 mm
- Stulp: 44 mm · Flügel: 80 mm / 60 mm
- Montante mobile: 44 mm · Anta: 80 mm / 60 mm

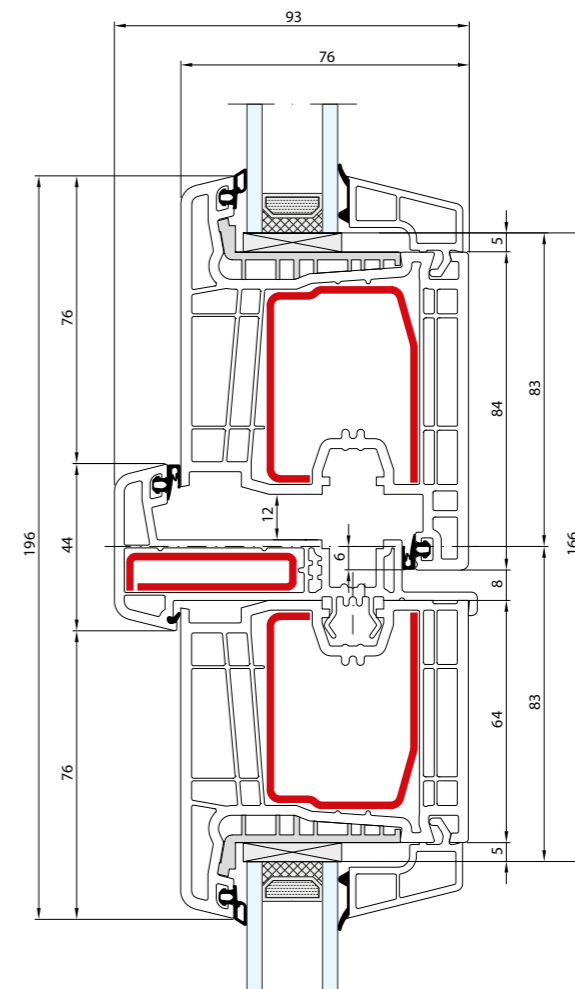
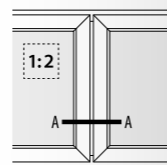

- Słupek ruchomy: 44 mm · Skrzydło: 104 mm / 84 mm
- Meneau mobile: 44 mm · Vantail: 104 mm / 84 mm
- Movable post: 44 mm · Sash: 104 mm / 84 mm
- Stulp: 44 mm · Flügel: 104 mm / 84 mm
- Montante mobile: 44 mm · Anta: 104 mm / 84 mm

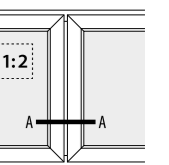

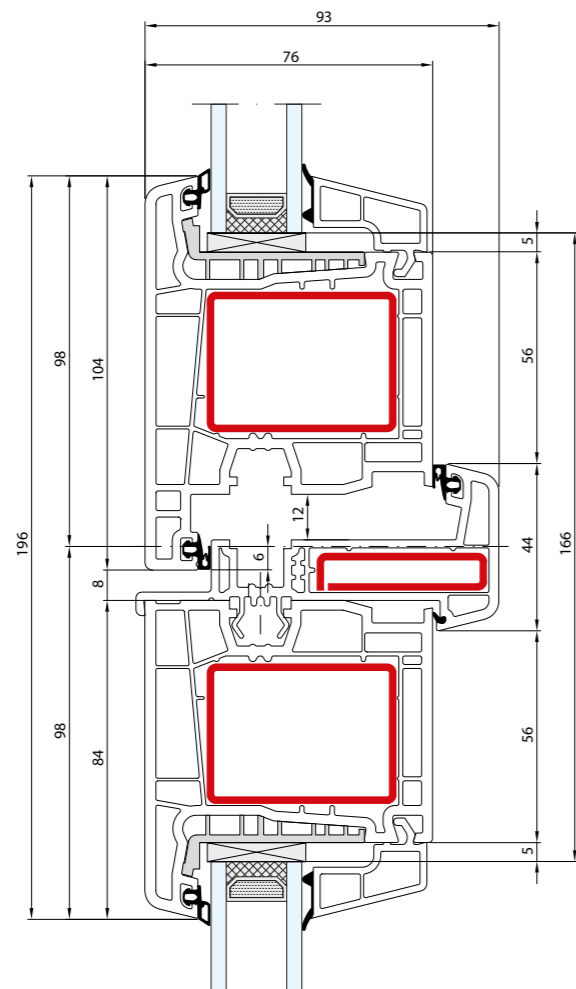

- Słupek ruchomy: 44 mm · Skrzydło: 104 mm / 84 mm
- Meneau mobile: 44 mm · Vantail: 104 mm / 84 mm
- Movable post: 44 mm · Sash: 104 mm / 84 mm
- Stulp: 44 mm · Flügel: 104 mm / 84 mm
- Montante mobile: 44 mm · Anta: 104 mm / 84 mm

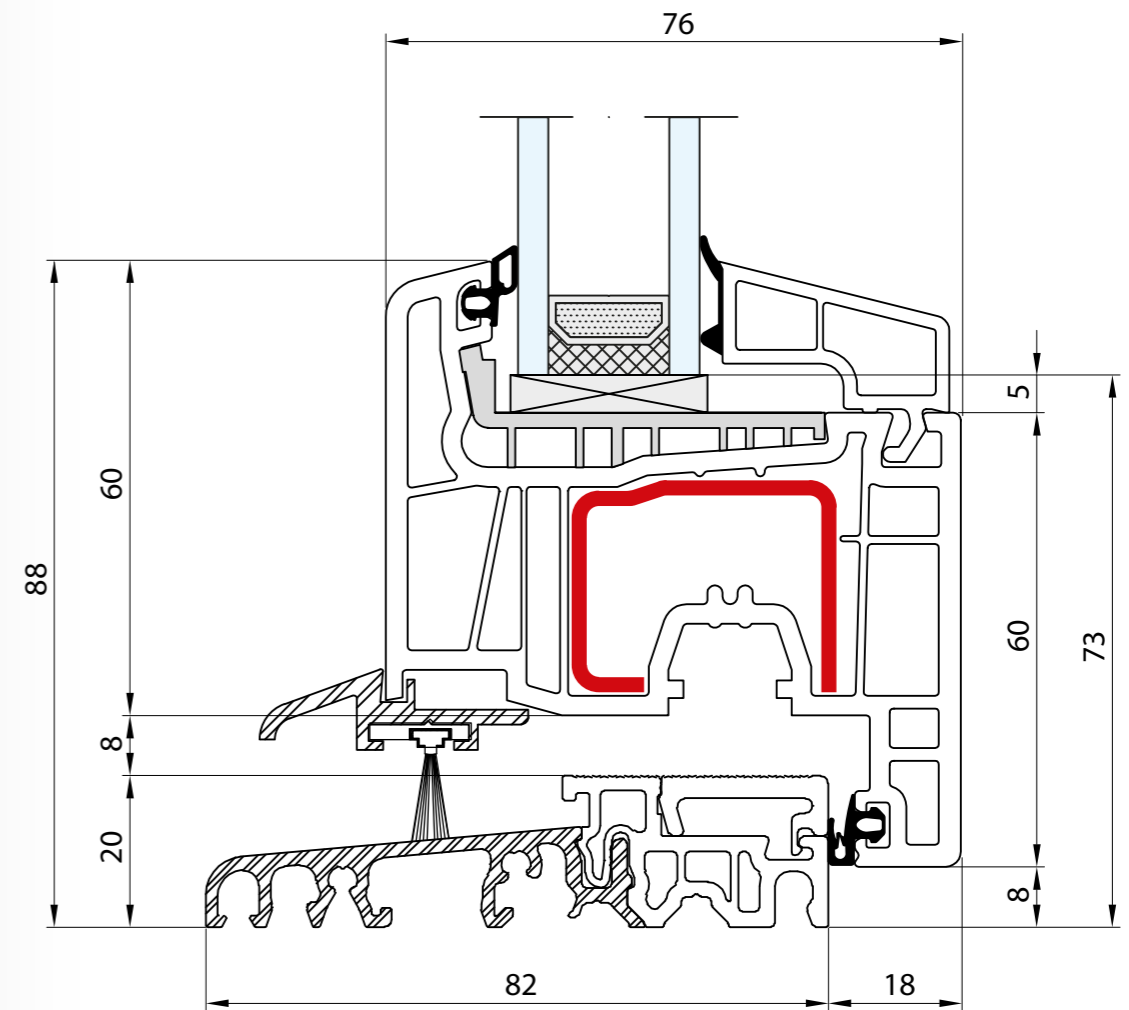
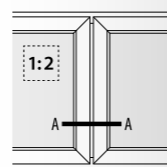

- Próg: 20 mm · Skrzydło: 80 mm
- Seuil: 20 mm · Vantail: 80 mm
- Threshold: 20 mm · Sash: 80 mm
- Schwelle: 20 mm · Flügel: 80 mm
- Soglia: 20 mm · Anta: 80 mm

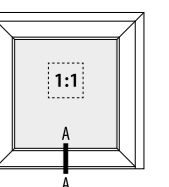



STREAMLINE 76

BLUEEVOLUTION 82

BLUEEVOLUTION 92

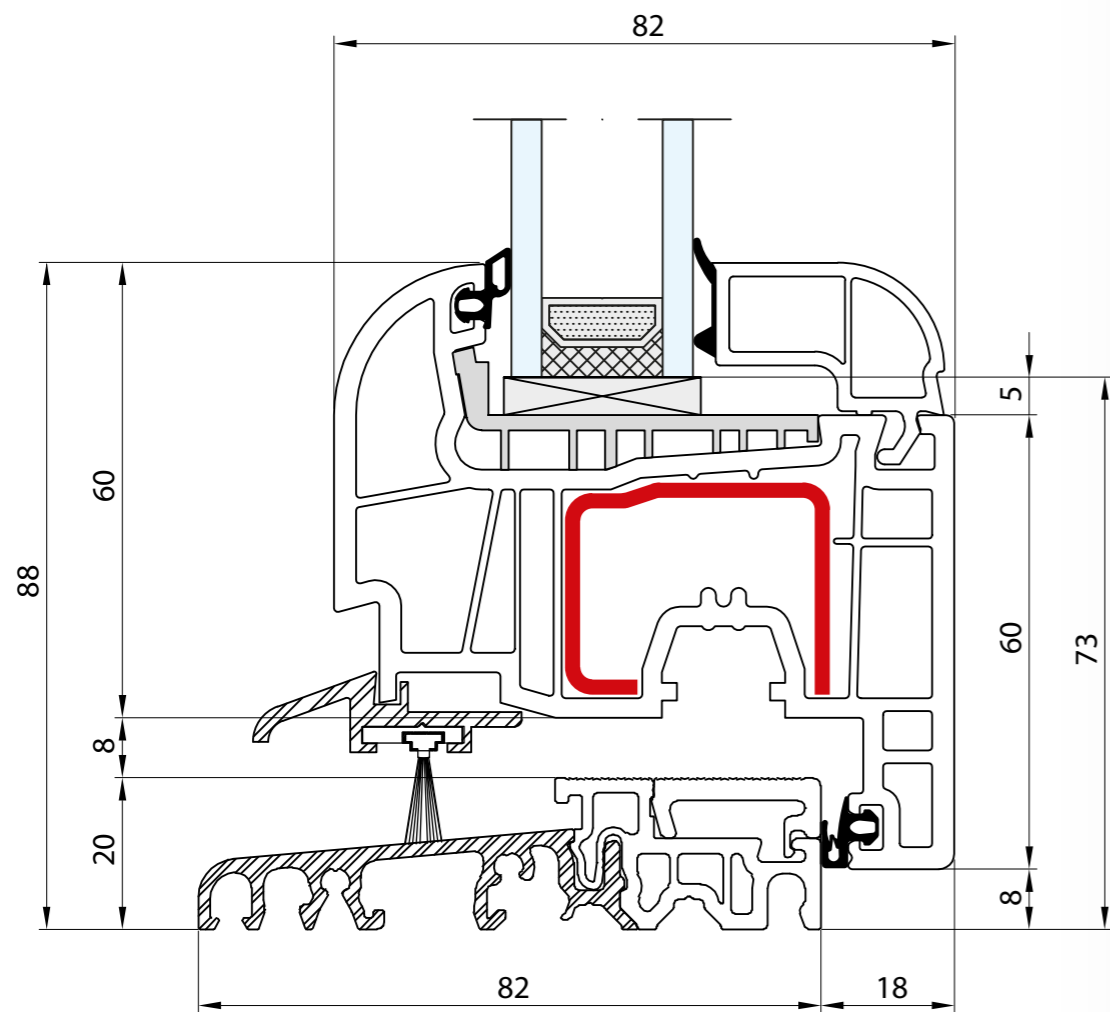

- Próg: 20 mm · Skrzydło: 80 mm
- Seuil: 20 mm · Vantail: 80 mm
- Threshold: 20 mm · Sash: 80 mm
- Schwelle: 20 mm · Flügel: 80 mm
- Soglia: 20 mm · Anta: 80 mm

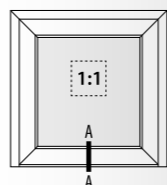

STREAMLINE 76

BLUEEVOLUTION 82

BLUEEVOLUTION 92

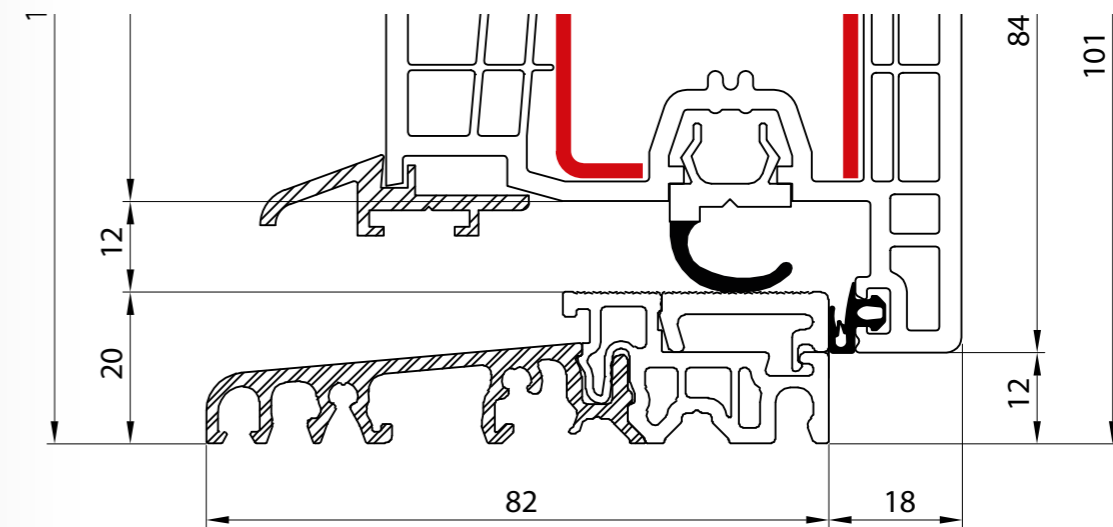
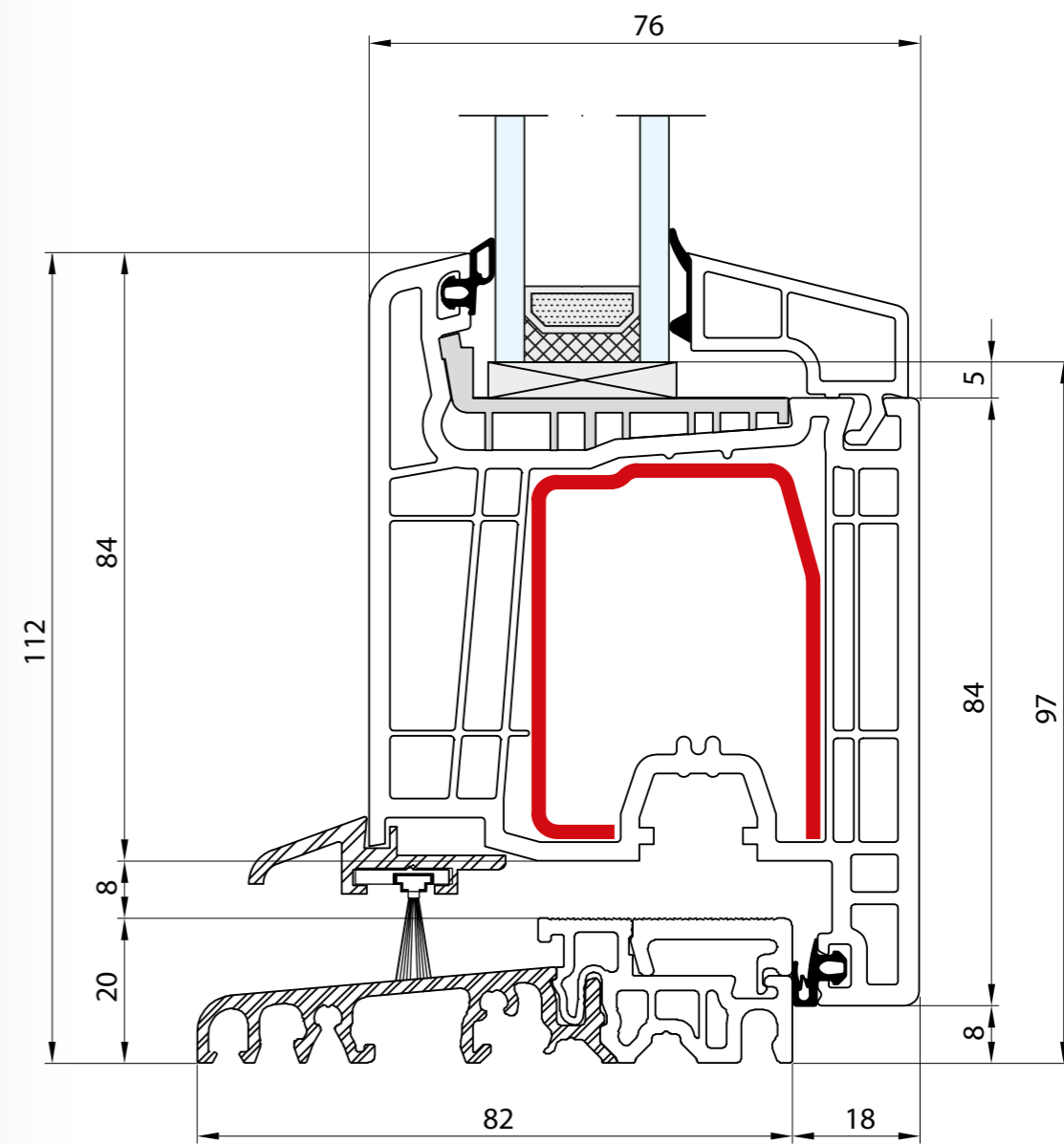

- Próg: 20 mm · Skrzydło: 104 mm
- Seuil: 20 mm · Vantail: 104 mm
- Threshold: 20 mm · Sash: 104 mm
- Schwelle: 20 mm · Flügel: 104 mm
- Soglia: 20 mm · Anta: 104 mm

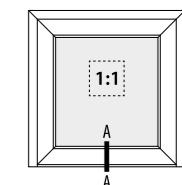

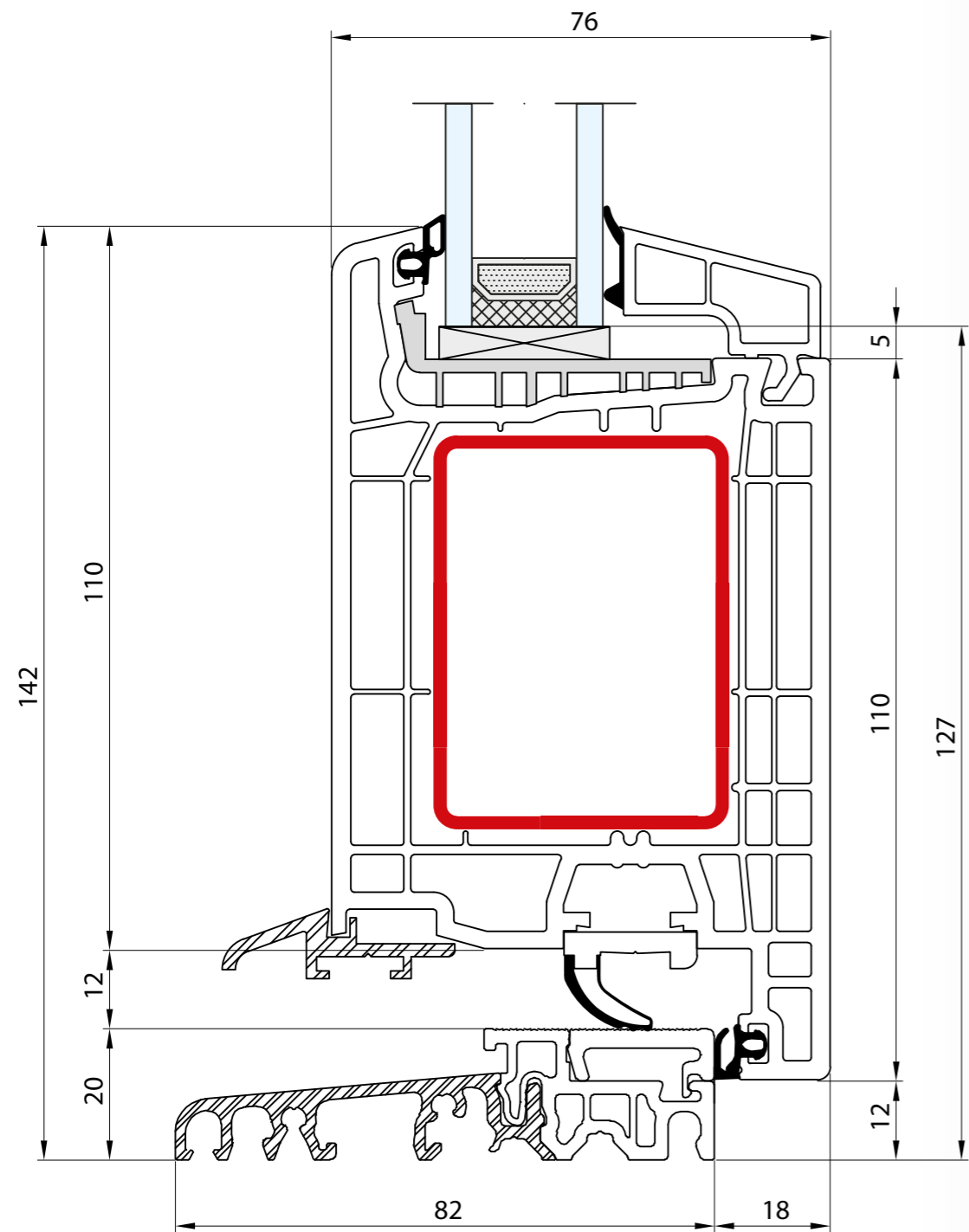

- Próg: 20 mm · Skrzydło: 130 mm
- Seuil: 20 mm · Vantail: 130 mm
- Threshold: 20 mm · Sash: 130 mm
- Schwelle: 20 mm · Flügel: 130 mm
- Soglia: 20 mm · Anta: 130 mm

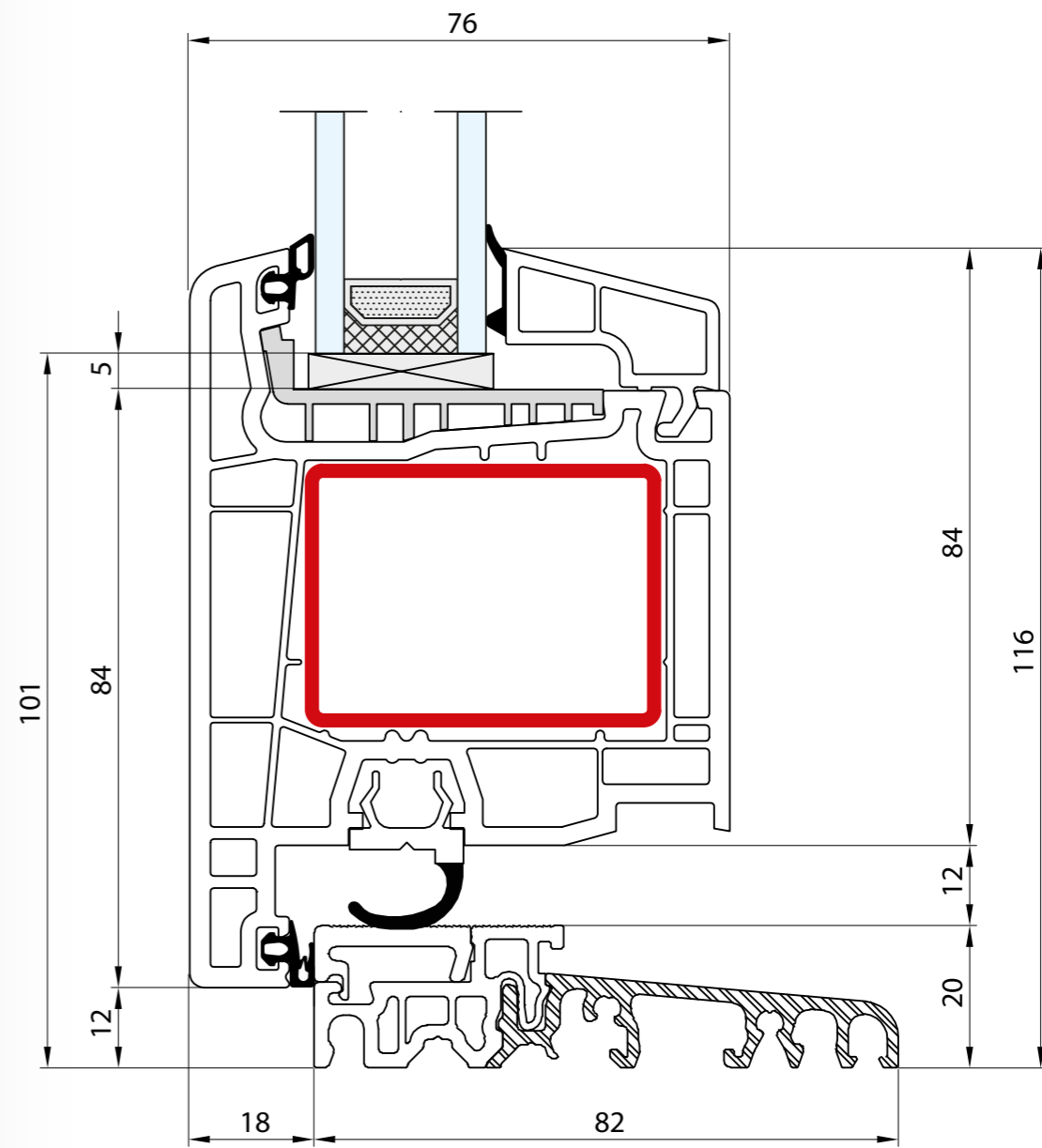
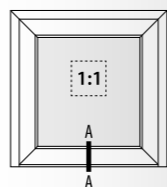

- Próg: 20 mm · Skrzydło: 104 mm
- Seuil: 20 mm · Vantail: 104 mm
- Threshold: 20 mm · Sash: 104 mm
- Schwelle: 20 mm · Flügel: 104 mm
- Soglia: 20 mm · Anta: 104 mm

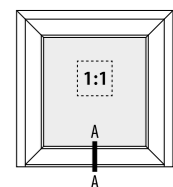

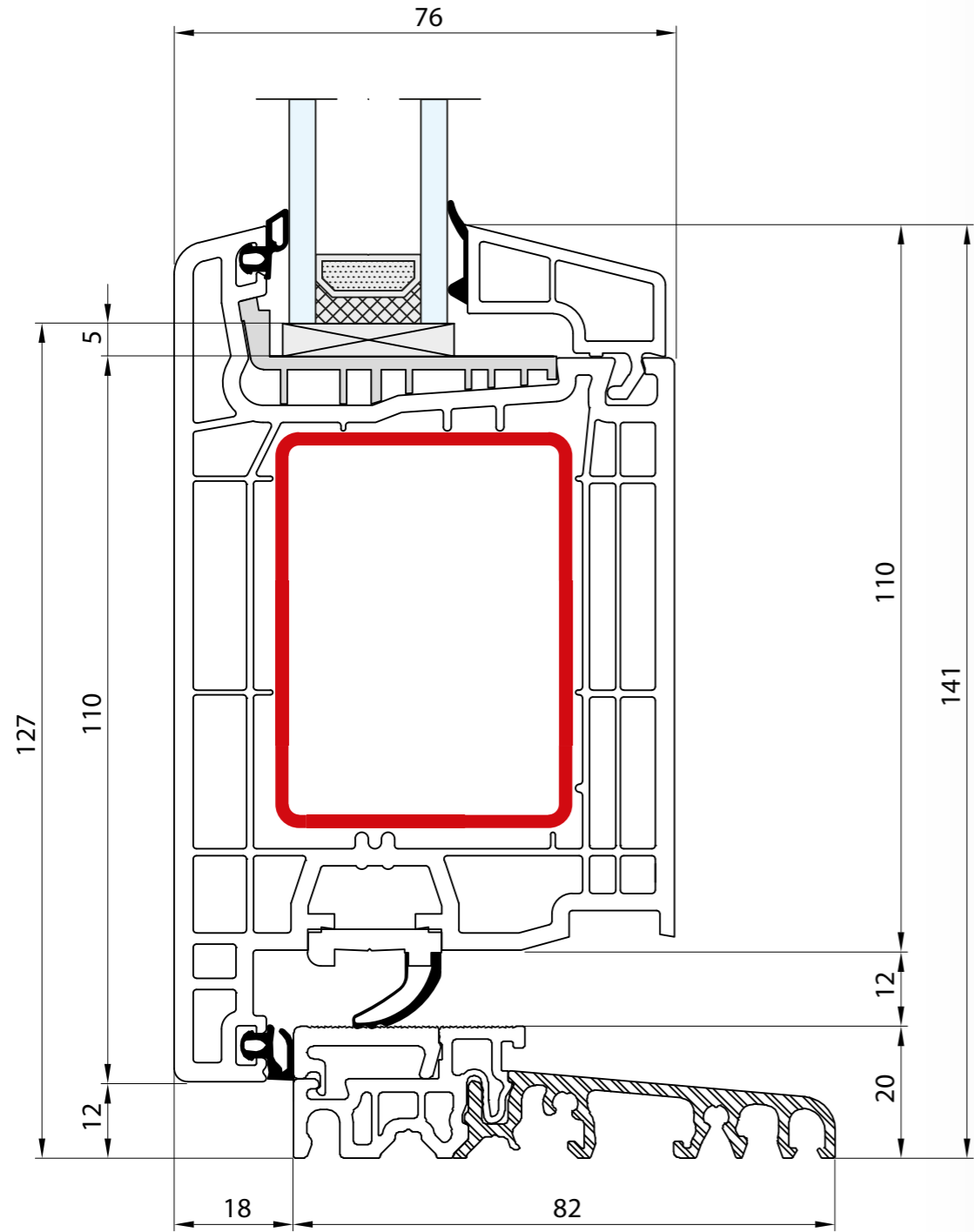

- Próg: 20 mm · Skrzydło: 130 mm
- Seuil: 20 mm · Vantail: 130 mm
- Threshold: 20 mm · Sash: 130 mm
- Schwelle: 20 mm · Flügel: 130 mm
- Soglia: 20 mm · Anta: 130 mm

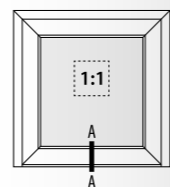

BLUEEVOLUTION 82



6	3	82	53	V-PERFECT TECHNOLOGY	ALU

1:2



1:2

STREAMLINE 76

BLUEEVOLUTION 82

BLUEEVOLUTION 92

STREAMLINE 76

BLUEEVOLUTION 82

BLUEEVOLUTION 92

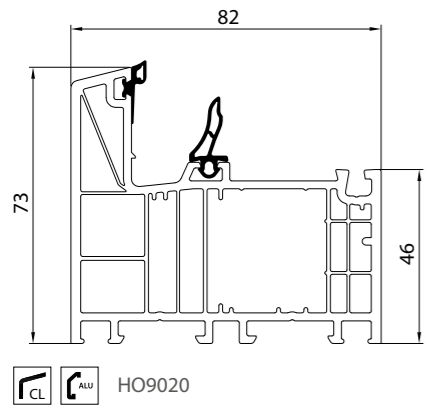

CL ALU HO9020

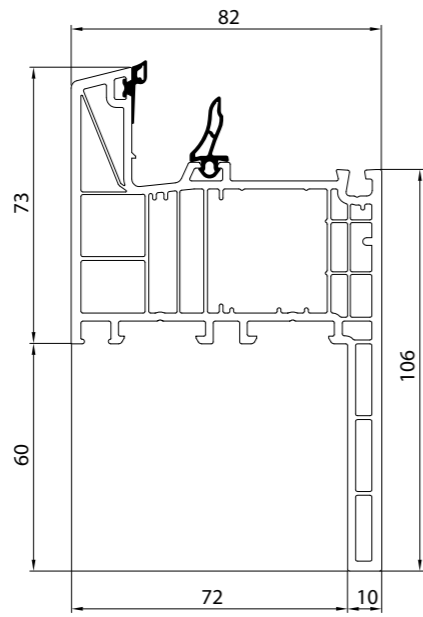

CL HO9100

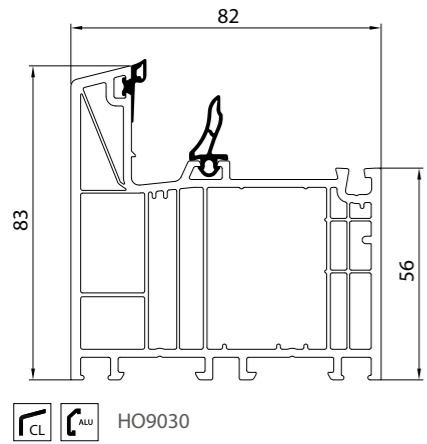

CL ALU HO9030

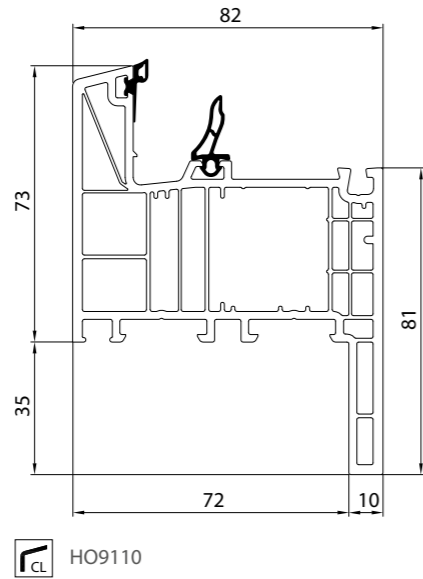

CL HO9110

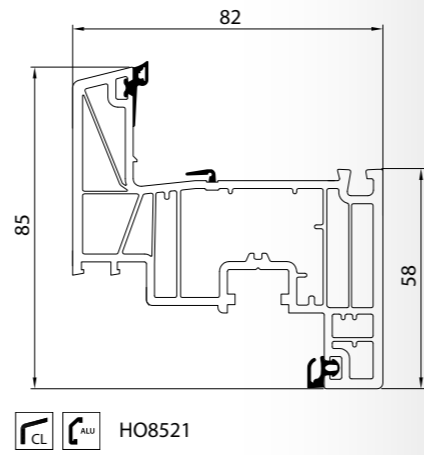

CL ALU HO8521

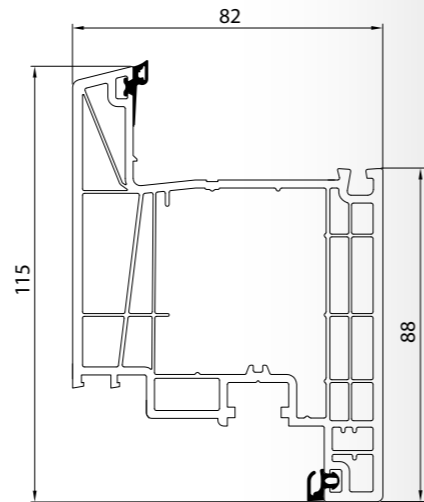

CL ALU HO8530

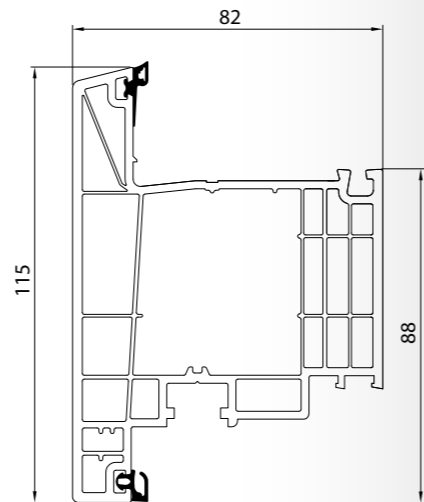

CL HO8540

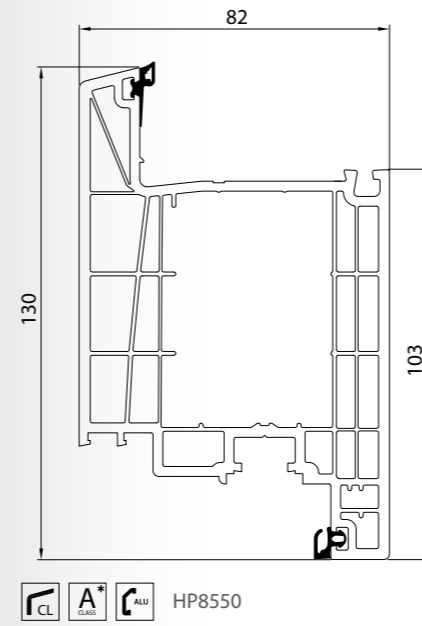

CL A* ALU HP8550

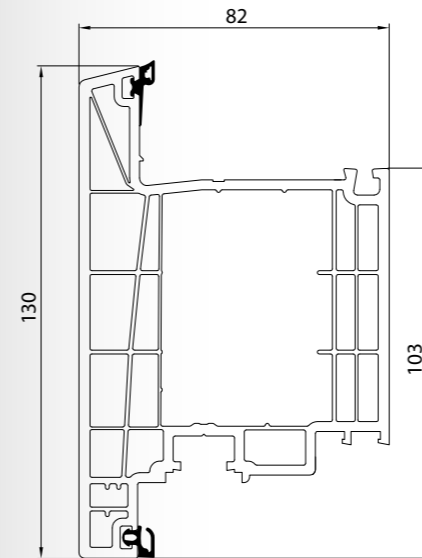

CL A* HP8560

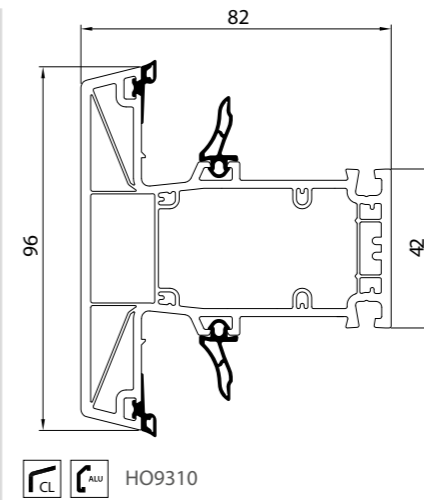

CL ALU HO9310

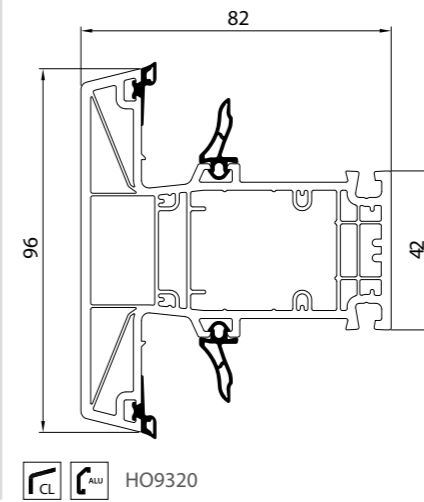

CL ALU HO9320

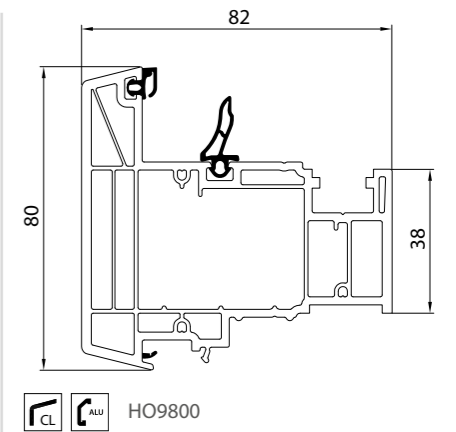

CL ALU HO9800

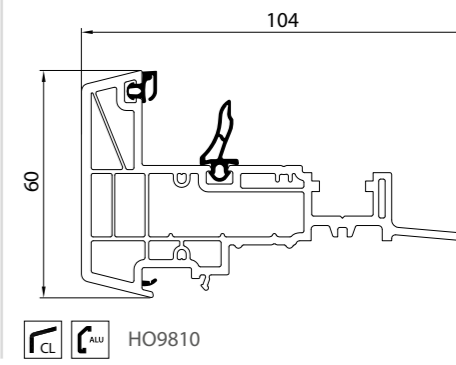

CL ALU HO9810